

**A MORPHOPHONOLOGICAL ANALYSIS OF BORROWED SEGMENTS IN
EKEGUSII LANGUAGE: AN OPTIMALITY PERSPECTIVE.**

MOSE GESARE EDINAH

C82/28600/2014

**A THESIS SUBMITTED TO THE SCHOOL OF HUMANITES AND SOCIAL
SCIENCES IN FULFILMENT OF THE REQUIREMENTS FOR THE AWARD
OF THE DEGREE OF DOCTOR OF PHILOSOPHY (LINGUISTICS) OF
KENYATTA UNIVERSITY**

FEBRUARY, 2020

DECLARATION

I confirm that this thesis is my original work and has not been presented in any other university. The thesis has been complemented by referenced works duly acknowledged. Where text, data, graphics pictures or tables have been borrowed from other works including the internet, the sources are specifically acknowledged through referencing in accordance with anti-plagiarism regulations.

Signature:.....

Date:

Mose Gesare Edinah

C82/28600/2014

This thesis has been submitted for examination with our approval as university supervisors.

Signature:

Date:

Dr. Nandelenga Henry Simiyu

Department of Literature, Linguistics and Foreign Languages

Kenyatta University

Signature:

Date:

Dr. Gerry Ayieko

Department of Literature, Linguistics and Foreign Languages

Kenyatta University

DEDICATION

To my dear Daddy: Mose James Bundi.

I dedicate this work for your immense support,

your strong will towards any situation,

your foresight and love for education.

ACKNOWLEDGEMENT

First, I wish to thank the almighty God, for the good health and sufficient Grace which has enabled me to enjoy sanity throughout the period of my study. Such a morphophonological journey requires a sound and alert mind. Secondly, I am greatly indebted to many people who made it possible for me to accomplish this huge task. In this regard, I want to thank my supervisors; Dr. Henry Nandelenga and Dr. Gerry Ayieko. Thanks to the lengthy discussion I had with Dr. Gerry on OT constraints that served as an eye opener and subsequently propelled me to write a concept which laid the foundation for this study. You devoted your time to teach me the basics of proper research writing and for that I am grateful, may God bless you abundantly. Dr. Nandelenga, you are a great teacher. You have consistently offered advice, kept a constant supply of writings on OT and given me guidance which has since made me understand at least the basics of OT which proved a hard nut to crack at the beginning. The constructive criticism I received enabled me to learn more as I progressed with this thesis. Thank you so much and God bless you.

I also wish to thank in a special way Dr. Phyllis Mwangi. Your constant follow-up on me and encouragement have always kept me pushing forward. As my mentor and role model, you are my greatest source of inspiration and may you be blessed. I am also grateful to have interacted with the current chair of the Department of Literature, Linguistics and Foreign Languages, Dr. Purity Nthiga. You gave me an opportunity to gain valuable teaching experience which has gone a long way in building me as scholar and a teacher. To Dr. Kebeya, thank you so much. Your constant encouragement and kind words have softened this terrain that was riddled with plenty of potholes.

To the entire staff of the Department of Literature, Linguistics and Foreign Languages which includes Dr. Gimode, Dr. Nyamasyo, Dr. Ogutu, Dr. Kiguru, Dr. Wangia, Dr. Ngure, Dr. Kanana, Dr. Njiri, Mr Omasaja, Mr Gicaga and and Ms. Owili and others not mentioned: I wish to thank you all for your helpful nature. As for my academic sisters and brothers like Dr. Omoke, Dr. Itumo, Dr. Wamaitha, Douglas, Kirui, Maisiba, Orpha and Dr. Norah; you have been good role models in this journey and I thank God for having strategically placed you in my path to illuminate the way. To the support staff of the Department of Literature, Linguistics and Foreign Languages like Mary, Morris, Wambui and Frashiah, God Bless you abundantly for your kindness and support.

I am also grateful to my family. My daddy Mose has been especially very instrumental in cheering me on and supporting me both morally and financially. It is your strong resolve and never giving attitude that has always inspired and driven me to overcome many challenges. God Bless you abundantly. To my mother, my mother-in-law, all my sisters and brothers I thank you so much for your support throughout my study period. I can't also forget the online troupes who comprised of friends and family who pulled together through the WhatsApp platform to wheel me to the homestretch financially. May God bless you abundantly. A journey of this magnitude requires a lot of peace, calmness and support. In this regard, I want, in a very special way, to thank my husband Fred. You not only sacrificed time to make up for my absences but maintained a solid supply of financial and emotional support. Yours is a big heart that knows no boundaries. May God bless you abundantly. Lastly, to my sons: Ryan, Roy and Ricky, thank you so much for your love. In this school of life, you have taught me the essence of appreciation and literally counting my blessing one by one and witnessing in real time; God's blessings.

TABLE OF CONTENTS

DECLARATION	ii
DEDICATION	iii
ACKNOWLEDGEMENT	iv
TABLE OF CONTENTS	v
LIST OF TABLES	ix
LIST OF FIGURES	x
ABBREVIATIONS, ACRONYMS AND SYMBOLS	xi
OPERATIONAL DEFINITION OF TERMS	xiii
ABSTRACT	xv
CHAPTER ONE: INTRODUCTION	1
1.0 Introduction	1
1.1 Background to the Study	1
1.2 Statement of the Problem	9
1.3 Objectives of the Study	9
1.4 Research Questions	10
1.5 Research Assumptions	10
1.6 Justification for the Study	11
1.7 Scope and Limitations of the Study	13
1.8 Chapter Summary	14
CHAPTER TWO: LITERATURE REVIEW AND THEORETICAL FRAMEWORK	16
2.0 Introduction	16
2.1 Literature Review	16
2.1.1 Ekegusii Phonemic Inventory and Prosody	16
2.1.2 Ekegusii Morphology	18
2.1.3 Structure of RP English	19
2.1.4. Phonological Adaptations of Borrowed Segments	20
2.1.5. Phonological Processes that Shape the Patterns of Borrowed Segments	24
2.1.6 Language Phonotactics that Constrain Borrowing	27

2.1.7 Morphological Adaptations and Morphotactics that Constrain Borrowing	31
2.2. Theoretical Framework	35
2.2.1 Optimality Theory	35
2.2.2 Generalized Alignment Theory	42
2.2.3 Justification for the Use of Optimality Theory and Generalized Alignment	45
2.3 Chapter Summary	47
CHAPTER THREE: RESEARCH METHODOLOGY	49
3.0 Introduction	49
3.1 The Research Design	49
3.2 The Study Population	49
3.3 The Sample and the Sampling Procedures	50
3.4 Research Instruments.....	51
3.5 Data Collection Procedures	53
3.6 Data Analysis Procedures.....	54
3.7. Data Management and Ethical Considerations.....	54
3.8 Chapter Summary	55
CHAPTER FOUR: PHONOLOGICAL ADAPTATIONS.....	56
4.0 Introduction	56
4.1 Adaptation of Vowel Sounds.....	56
4.1.1 The Adaptation of /i/ in Ekegusii.....	57
4.1.2. The Adaptation of /e/ in Ekegusii.....	60
4.1.3. The Adaptation of /ɛ/ in Ekegusii.....	64
4.1.4. The Adaptation of /a/ in Ekegusii.....	67
4.1.5. The Adaptation of /o/ in Ekegusii	70
4.1.6. The Adaptation of /u/ in Ekegusii	72
4.2. The Adaptation of Consonants in Ekegusii	75
4.2.1 Adaptation of English Consonants /b/, /p/, /v/, /f/ to Ekegusii's /β/.....	76
4.2.2 Adaptation of English Consonant /g/ to Ekegusii's /ɣ/, /k/, / ⁿ g /.....	80
4.2.3 Adaptation of English Consonants /d/, /θ/ to Ekegusii's /t/.....	82
4.2.4 Adaptation of English Consonants /z/, /ʃ/ /ʒ/ to Ekegusii's /s/.....	88

4.2.5 Adaptation of English Consonant /l/ to Ekegusii's /r/.....	92
4.2.6 Adaptation of English Manner-contour Consonants	93
4.3 Phonological Processes in Adaptation.....	99
4.3.1 Epenthesis.....	99
4.3.2 Deletion	102
4.3.4 Resyllabification.....	110
4.3.5 Substitution.....	112
4.3.6 Monophthongization.....	115
4.3.7 Lenition.....	117
4.4 Phonotactics in Ekegusii Language that Constrain Borrowing	121
4.4.1 Segmental Level Constraints.....	121
4.4.1.1 Vocalic Phonemes	121
4.4.1.2 Consonantal Sounds	123
4.4.2 Syllabic Level Phonotactics.	141
4.4.2.1 V Syllable Structure	143
4.4.2.2 CV Syllable Structure.....	147
4.4.2.3 CGV Syllable Structure.....	150
4.5 Chapter Summary	157
CHAPTER FIVE: MORPHOLOGICAL ADAPTATIONS AND MORPHOTACTICS IN BORROWED SEGMENTS	158
5.0 Introduction.....	158
5.1 Ekegusii Noun Morphology	158
5.2 Morphological Class Adaptations	160
5.3 Inflectional and Derivational Morphology of Loanwords.....	168
5.4 Morphological Processes.....	181
5.5 Chapter Summary	188
CHAPTER SIX: SUMMARY, CONCLUSIONS AND RECOMMENDATIONS..	189
6.0 Introduction	189
6.1 Summary of Research Findings.....	189
6.2 Conclusions	203

6.3 Recommendations	204
6.4 Outstanding Issues and Areas of Further Research	206
REFERENCES	209
APPENDIX 1: INTERVIEW GUIDE FOR RESPONDENTS	217
APPENDIX II : ENGLISH LOANWORDS IN EKEGUSII.....	219
APPENDIX III: TIME SCHEDULE.....	227
APPENDIX IV: BUDGET.....	228
APPENDIX V: APPROVAL OF RESEARCH THESIS FROM KENYATTA UNIVERSITY	229
APPENDIX VI: RESEARCH AUTHORISATION FROM NACOSTI.....	230
APPENDIX VII: RESEARCH PERMIT FROM NACOSTI	231

LIST OF TABLES

Table 2.1: Ekegusii Consonant Phonemes 17

LIST OF FIGURES

Figure 1.0 The Syllable Structure.....	6
Figure 2.1: Ekegusii Vowel Chart	17
Figure 4.1 V Syllable Structure	143
Figure 4.2 CV Syllable Structure	147
Figure 4.3 CGV Syllable Structure	150

ABBREVIATIONS, ACRONYMS AND SYMBOLS

ALIGN-PrWd-L, Stem L	Align prosodic word left, stem left
ALIGN-FT-L	Align foot left
ALIGN-Affix-L	Align prefix left
ALIGN-PrWd-R, Stem, R	Align prosodic word right, stem right
ALIGN-FT-R	Align foot right
ALIGN-Affix-R	Align suffix right
DIPH	Diphthong
ANT	Anterior
C	Consonant
CC	Complex Cluster
CGV	Consonant Glide Vowel
CN	Consonant Nasal
CL	Consonant Liquid
CO	Consonant Obstruent
CONT	Continuant
CV	Consonant Vowel
DENT	Dental
EVAL	Evaluator
Ft	Foot
GEN	Generator
GA	Generalized Alignment

IO	Input – Output mapping
LAB	Labial
LAB-DENT	Labial Dental
LAT	Lateral
OT	Optimality Theory
OBSVOI	Obstruent Voicing
OCP	Obligatory Contour Principle
REDUCED-V	Reduced Vowel
PrWd	Prosodic Word
RP	Received Pronunciation
SON	Sonorant
SPE	Sound Patterns of English
SSP	Sonority Sequencing Principle
*	Violation
!	Serious or fatal violation
☞	Optimal Candidate
σ	Syllable

OPERATIONAL DEFINITION OF TERMS

- Constraints:** These are structural requirements that may either be satisfied or violated. Constraints are of two types: markedness constraints which require that output forms meet some criterion of structural well-formedness and faithfulness constraints which demand similarity between the output and input forms. An input may satisfy a constraint if it fully meets the structural requirement, while any form not meeting this requirement is said to violate it.
- Crucial ranking:** This refers to when constraints which are high-ranked in a language take precedence over the low-ranked. For example; a hierarchy like [C1 » C2 » C3], constraints 1, 2 and 3 are crucially ranked so that C1 dominates C2 while C2 dominates C3.
- DEP-IO:** A universal constraint which requires that each segment in the output form has a corresponding segment in the input form. That is, the output is entirely dependent on input and the constraint is violated if any segments are inserted.
- Domination:** A constraint hierarchy ranking relation in a language is referred to as domination. The high-ranked of a pair of conflicting constraints takes precedence over the low-ranked. The hierarchy like [C1 » C2], reads as 'C1 dominates C2' which is a statement about the relative priority of C1 over C2 in a particular language. In OT, constraints are arranged in strict-domination hierarchies such that variation in ranking is meant to signify different languages.
- Evaluator:** It is a function that evaluates all the possible candidates supplied by the generator and selects the optimal output.
- Faithfulness:** Faithfulness refers to the relationship between the surface forms and their lexical representations. It is a constraint that imposes a requirement that there should be some semblance between output form and its input. The faithfulness constraint counterbalances the markedness constraints in selecting the optimal forms.
- Generator:** It is the function that is responsible for the free generation of potential output forms that is subject only to very general universal well-formedness constraints.
- Harmony:** Refers to relative well-formedness based on some faithfulness or markedness demands. It is relative because the severity of violations of constraints in the hierarchical ranking is considered. Some violations must occur on the optimal candidate because constraints impose conflicting requirements, however, violations must be minimal.
- IDENT (F):** It is a universal constraint that requires that every feature (F) in the input segment is 'identical' to every feature in the output segment. This constraint is violated if for instance, a segment

changes from a voiceless labial dental fricative /f/ to the voiced labial dental /v/ in the output.

- Markedness:** Markedness entails that all types of linguistic structures consist of unmarked and marked values. Unmarked values are cross-linguistically preferred and are basic in all grammars whereas the marked structures are cross-linguistically avoided and used by grammars only to create contrasts.
- MAX-IO:** It is a universal faithfulness constraint that requires that each segment in the input form (I) has a corresponding segment in the output form (O). That is, the input is ‘maximally’ represented in the output. The constraint is violated if a segment is deleted.
- Morphotactics:** These are morphological constraints that determine what is permissible and impermissible in given language. What is not acceptable in language is repaired through various morphological processes like morpheme epenthesis.
- Optimal form:** It is the candidate that is better on a hierarchy of constraints, the one that survives after all the filtering of competing candidates. It is also the winning candidate occurring at the surface by minimally violating low ranked constraints.
- Phonotactics:** It refers to the phonological arrangement of distinctive sound units in a given language. This arrangement determines what is permissible in a language. What is not acceptable is repaired through various phonological processes like deletion and epenthesis.
- Syllable:** A syllable is the smallest possible unit of speech and it consists of a vocalic peak, which may be accompanied by a consonantal onset or coda.

ABSTRACT

Language phonotactics and morphotactics are very significant in determining linguistic borrowing. Despite this significance, fewer studies have explored this interplay. This study undertook a morphophonological analysis of borrowed segments in Ekegusii. To achieve this, the study described the phonological adaptations, phonological processes that shape the patterns of the borrowed segments in Ekegusii, established both the phonotactics and morphotactics of the Ekegusii language that constrain borrowing and ascertained the extent to which Optimality Theory accounts for borrowing in Ekegusii. The Optimality Theory as proposed by Prince and Smolensky (1993 and 2004) and Kager (1999) as well as Generalized Alignment Theory by McCarthy and Prince (1993a) were used in the study. A descriptive linguistic fieldwork design guided this study. This study targeted proficient adult Ekegusii speakers both male and female who were neither too young nor too old, had all their own teeth and did not have any speech disorders. To arrive at the appropriate study sample, purposive sampling was used and it was carried out in two stages. First, the researcher sampled two hundred words from Ekegusii dictionary, then supplemented from introspection. Secondly, the researcher sampled three proficient adult Ekegusii speaker respondents (two males and one female) who were interviewed to overtly realize the sound patterns in the Ekegusii borrowing processes. Data collection instruments included a wordlist which was subjected to the respondents through interviews which were recorded to yield spoken data. Data analysis revealed that loanwords in Ekegusii undergo both phonological and morphological adaptations. First, on phonological adaptations the findings revealed that English vowels tend to be substituted with those in Ekegusii which they have shared features in terms of horizontal and vertical tongue position, tenseness as well as shape of the lips. On consonantal segments, data showed that the sounds that were adapted shared at least the major-class features, laryngeal, manner and place features with those they replaced. In addition, segments that are unmarked and preferred cross linguistically were adapted over the marked ones. OT constraints accounted for all the phonological and morphological processes whereby markedness constraints dominated the faithfulness constraints. Phonotactics of Ekegusii language that constrain borrowing were revealed at two levels: segmental and syllabic. On the morphological adaptations, it was established that borrowed segments are mapped to different noun classes with the prefix marker being the overriding factor. It is expected that this study will contribute to the existing literature on Bantu languages in relation to borrowing within the framework of Optimality Theory.

CHAPTER ONE: INTRODUCTION

1.0 Introduction

This chapter highlights: the introduction, the background to the study, statement of the problem, the research objectives, research questions and research assumptions. In addition, justification for the study, scope and limitations of the study as well as the chapter's conclusion are presented.

1.1 Background to the Study

Languages are very dynamic, and in an attempt to cope with the challenges of new concepts, emerging technologies and new products, speakers of a particular language may have to borrow from a foreign language (Hall-lew, 2002; Mavoungou, 2005; Nagy, 2010). Therefore, the notion of loanwords in world languages which are in language contact is a phenomenon that is very common and unavoidable. Linguistic borrowing is a process whereby languages transfer linguistic constructions which can be syntactic, morphological, lexical and phonological from a 'donor' language to a 'recipient' language because of contact situations between speech communities (Faezeh & Zafaranlu, 2013; Tsvetkor & Dyer, 2016). However, Tsvetkor and Dyer are quick to note that borrowing can occur across unrelated languages. Mavoungou (2002) concurs with them by noting that borrowing takes into account a situation whereby a language takes new linguistic material from another language (donor language) and incorporates them into the recipient language without necessarily translating. A language can borrow

whole words, morphemes, phonemes and even syntactic features. Thus, Ekegusii language is not an exception as far as linguistic borrowing is concerned as it borrows from English and other Kenyan Languages.

Ekegusii is a Bantu language which is spoken in Kenya and it is classified as E42 by Guthrie (1971). According to Nurse and Phillipson (2006), Ekegusii is closely related to Igikuria, another Kenyan language, and Ngurimi and Zanaki, both of which are spoken in Tanzania. They further point out that Ekegusii belongs to Eastern Nyanza Sub-group of East Nyanza or Suguti of the Lacustrine Bantu. Another classification is by Lewis (2009) that it is Niger Congo, Volta-Congo, Bennue-Congo Bantoid, Southern, Narrow Bantu. Maho (2008) classifies the language as JE42 and labels it Gusii. The Census Report of 2009 placed the Gusii total population at 2,205,669 speakers spread over two counties; Kisii and Nyamira.

Ekegusii is in diglossic relation with English since it is used as a first language by its speakers while English is taught and used as a second language by the educated members of the community. English is essentially a Germanic language of the Indo-European family. Its roots in Kenya can be traced back to the colonial period when the British introduced it (Kioko & Muthwii, 2001). Back then, English played a vital role in education and administration as well as access to white collar jobs. Up to date, English still plays a crucial role in Kenya as it is used as the official language in the education sector, government, parliament, diplomacy and to conduct business internationally

(Ogechi & Kembo-Sure, 2006). Moreover, the entrenchment of English in the Kenyan Constitution (2010) as an official language further strengthens its vitality.

English and Kiswahili are the most dominant and influential cross-ethnic languages in the Kenyan linguistic situation (Mazrui & Mazrui, 1993). Consequently, across the diverse ethnic communities in Kenya, English is used widely. Therefore, Ekegusii borrows extensively from English. Besides, Hoffer (2005) observes that what stands out in intercultural contact between languages is a set of loanwords borrowed into the vocabulary of the languages involved. Ekegusii language has had a historical contact with English which has led to borrowing.

The most easily understood motive for linguistic borrowing is that of need (Russ, 1992). Typically, borrowing because of need is said to occur when a new thing or concept is encountered which already has a name in the donor language but not in the borrowing language or at least not one known to the borrower in that language. However, this is not the only motivation for borrowing. Linguistic borrowing can occur due to prestige and social status. If speakers of certain language feel that a particular language is more prestigious than their own, then they are bound to borrow. In other words, borrowing for need is necessary borrowing because there is a lexical gap while borrowing for prestige is unnecessary borrowing because there already exists an adequate way of expression in the borrowing language. Additionally, need borrowing goes a long way in enriching the lexis of a language. Since languages are dynamic, they are expected to enrich their lexis by incorporating names of new trade items, newly encountered

products, new features of the natural world as well as new scientific discoveries or intellectual concepts. Thus, Ekegusii has had to fill the gaps by borrowing in a world where innovations are constantly taking place.

Coincidentally, when languages borrow from each other, their grammatical systems are structured differently; therefore, their phonological and morphological features cannot be accounted for in terms of their similarities. A universal phonology or morphology for all languages is not possible because people use language to signal their social status in their speech communities. Amid the difference in features of language phonologies and morphologies, speakers of a language will find themselves in situations where they have to use the loanwords of another language. When this occurs, speakers tend to perceive and relate each of the segments in the foreign word using their own native systems. They ensure that strings which break the syllable structure or any other phonotactics are disallowed (Gussenhoven & Jacobs, 2005). Morphologically, loanwords undergo morphological structure modification so as to achieve harmony with the established predominant pattern and root system of the recipient language.

Languages do not arbitrarily borrow from other languages but the loanwords are changed to conform to the phonological and morphological systems of the borrowing language. In fact, loanwords must undergo modification to fit in the phonology and morphology of the recipient language in a process called nativization (Sarkar, 2012). Silverman (1992) argues that nativization does not just occur, rather it triggers a number of processes in the native speaker's mind. They include; perception, whereby the

speaker perceives the acoustic input of the foreign element; interpretation of the foreign element and finally the operative, where the speaker maps the foreign segment to conform to the phonotactic and morphotactic constraints of his or her language. The purpose of this study was to establish how Ekegusii speakers perceive and map loanwords from English so that they conform to the dominant and distinctive phonotactics and the morphological constraints of Ekegusii.

Evidently, it seems that loanword adaptation in languages is a highly constrained process. Gussenhoven and Jacobs (2005) illustrate this when they give an example of the English language. They argue that elements which re-occur do not do so in all possible orders, instead there is a higher ranked constituent than a segment which imposes restrictions on the occurrence of segments and the order in which they occur. A case in point is the English language whereby the sounds: [k], [æ] and [t] can form sequences like *cat*, *act* and *tack* but the same cannot be for *[ætk] yet the same combination forms a word like *atkins* but in this case the /t/ is in the coda position while /k/ is the onset of the following syllable. Language phonotactics concerns itself with the choices and restrictions which languages allow in the syllable structure thus leading to possible word formations. Whether the whole process is phonetically or morphologically driven is what the study sought to investigate from the perspective of loanwords in Ekegusii.

Loanword adaptation varies from one language to another because different languages rank constraints differently when they form syllables (Fossi, 2012). The syllable is

indeed at the heart of phonological representations, forming a unit upon which phonological systems are organised (Katamba, 2003). Whereas many phonologists envisage a branching, hierarchical syllable structure, the traditional structural view presents the syllable as having initial consonant(s) called *onset*, while the vowel part is *peak* and the closing or the last consonant(s) that make the *coda*.

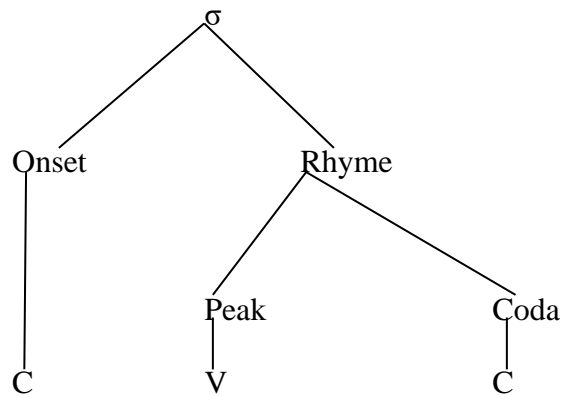

Figure 1.0 The Syllable Structure

Rhyme is the only essential element of the syllable. It is obligatorily present in all syllables in languages. However, what varies from language to language are the elements that can be part of the rhyme. Whereas the nucleus slot in the rhyme is typically occupied by a vowel, occasionally a consonant may fill the position (Katamba, 2003). The simplest syllable structure is formed by languages that take a short vowel as nucleus and optionally allow a maximum of one consonant in the onset (Blevins, 1995). Obviously, languages have varied syllabic structures; they range from very simple to complex forms. English in particular has a very complex syllabic structure which allows up to three consonants at the onset and four consonants at the coda (Roach, 2009). Therefore, depending on what is permissible or not, the syllable not only determines the

phonotactics of languages but also triggers different phonological processes especially if the languages concerned have different syllabic structures like the case of Ekegusii borrowing from English.

Furthermore, loanword phonology has revealed adaptations employed by native speakers who possess a phonological system which they use to perceive and produce forms which belong to another phonological system (Sarkar, 2012). Whether this process is entirely phonological or has a morphological influence continues to draw attention from researchers. What is however clear is that loanwords entering a borrowing language from a source language have to be modified to conform to the borrowing language's phonological and morphological system. This system provides a platform through which the phonotactics and morphotactics of the borrowing language can be investigated and accounted for. Since language phonologies and morphologies are different, modification of loanword adaptations occur given that foreign segments often contain alien structures that lack in the underlying forms in the native phonology. Davis (1993) adds that loanwords can provide much insight on phonological systems in general since they involve at least two phonological systems: the recipient language and the source language. Consequently, there are many questions which arise when two different phonological systems are in contact with each other. They include: which language plays a significant role in influencing phonological and morphological adaptations in loanwords? Secondly, how is the evident conflict in sound adaptation resolved in language contact situations? and lastly to what extent do loanword users display varied sound patterns in borrowed segments? Davis notes that loanword

phonology can reveal language constraints in the recipient language bringing about unique patterns of loanword adaptations. This formed the basis upon which the study examined the phonological and morphological adaptations of the Ekegusii borrowed segments from English.

The process of loanword adaptation appears then to be constraint driven and repairs in 'real-time' (Faezeh & Zafaranlu, 2013). This means that when speakers adapt loanwords, they try to be faithful to the source word while at the same time they make the loanword to conform to native language phonotactic constraints, segmental inventory and prosodic structures (Kenstowicz & Atiwong, 2004). Prince and Smolensky's (2004) constraint based model (Optimality Theory, henceforth OT), with its key notions of markedness and faithfulness constraints was seen as best suited to explain loanword adaptations. Indeed, a speaker will be faced with choices whenever adapting a foreign word as to which feature in the source word ought to be preserved and which are to be discarded. Speakers tend to preserve features which will easily be noted in case they are absent and when making modifications, they are as non-obtrusive as possible by substituting sounds that most natural and closely resemble the original. For morphological adaptation, speakers will tend to maintain their system word patterns at the expense of the borrowed loanword patterns. This study sought to establish how faithfulness and markedness constraints in OT constrain both the phonological and morphological adaptations of loanwords in Ekegusii.

1.2 Statement of the Problem

Language phonotactics and morphotactics which by large encompass the syllabic structure and morphological constraints of the recipient language are crucial in determining linguistic borrowing. Despite this significance, few studies have been carried out especially on the syllabic structure and the extent to which the syllable constrains borrowing as well as how the morphological constraints come to play when borrowing takes place. This is the linguistic knowledge gap the study intended to fill. Secondly, borrowing which has been done in Ekegusii focuses on Kiswahili which is a Bantu language and the description of the syllabic structure without reference to how it constrains borrowing. Ekegusii has extensively borrowed from English which is known to have an elaborate inventory and a complex syllabic system. Thirdly, literature in loanword phonology has shown that when borrowing occurs, loanwords undergo morphological structure modification so as to achieve harmony and correspondence with the established dominant pattern and root systems of the recipient language. This means that a language's phonology alone may not adequately explain how loanwords are adapted without reference to its morphological constraints that it imposes on the output loanwords. That is why this study carried out morphophonological analysis of borrowed segments in Ekegusii.

1.3 Objectives of the Study

The main objectives of the study were:

- i. To describe the phonological adaptations of borrowed segments in Ekegusii

- ii. To describe and analyse the phonological processes that shape the patterns of the borrowed segments in Ekegusii
- iii. To establish the phonotactics of the Ekegusii language that constrain borrowing from the source language
- iv. To discuss the morphological adaptations and morphotactics of Ekegusii language that constrain borrowing.
- v. To describe the extent to which Optimality Theory accounts for borrowing in Ekegusii

1.4 Research Questions

The specific research questions the study sought to answer were:

- i. What are the phonological adaptations of borrowed segments in Ekegusii?
- ii. What are the phonological processes that shape the patterns of the borrowed segments in Ekegusii?
- iii. Are there phonotactics of Ekegusii language that constrain borrowing from the source language?
- iv. How do the morphological adaptations and morphotactics shape the patterns of borrowed segments in Ekegusii?
- v. To what extent does Optimality Theory account for borrowing in Ekegusii?

1.5 Research Assumptions

The study was based on the following assumptions:

- i. There exist phonological adaptations in borrowed segments in Ekegusii

- ii. Phonological processes influence the sound patterns of the borrowed segments in Ekegusii
- iii. The existence of phonotactics in the Ekegusii language constrains loanword borrowing.
- iv. Morphological adaptations and morphotactics of Ekegusii language influence the patterns of borrowed segments in Ekegusii.
- v. Optimality theory can account for linguistic characteristics of borrowing in Ekegusii

1.6 Justification for the Study

Although there exists extensive literature on language borrowing, little has been done specifically on Ekegusii borrowing from English through the constrained-based model; OT. This notwithstanding, Appel and Muysken (2005) observe that most African languages have had contact with a number of European, Asian and other African languages mainly due to migration, colonial experiences, trade and technological advancements. No wonder then, loanword phonology has continued to attract attention as a potential research area that can shed light on universal phonological and morphological patterns (Sayahi, 2005). Therefore, this study is expected to add knowledge to the continuing research on loanwords in African languages and in particular, Bantu languages.

The interplay of both phonology and morphology is important when accounting for linguistic borrowing in languages. This study contributes to this area by uncovering the role played by the phonotactics and morphotactics of Ekegusii through the constraint-based model; OT. By examining the phonotactics and morphotactics, the study determined how the sounds from the loanwords are modified in Ekegusii and the dominant word patterns that guided the adaptation of the loanwords.

Furthermore, this study investigated the phonological processes that shape the patterns of borrowed segments in Ekegusii. The phonological processes established in Ekegusii borrowing can be compared to those of other Bantu languages or other language families in the context of borrowing through the optimality perspective.

In addition, the phonology of a particular language is determined by how a language ranks a set of universal constraints which will bring about variability in the languages of the world (Prince & Smolensky, 2004). This study is significant because it examined how Ekegusii ranks its constraints as it modifies loanwords from English. By ranking the constraints, the study proposes both the phonotactics and morphotactics that come to play when borrowing occurs and how OT accounts for them. The study also discusses the various morphological processes reported in loanwords in Ekegusii; therefore, contributing to the literature on loanword morphology in Bantu languages.

Optimality Theory's central claim is that it can be used to account for all phenomenon in languages. This study is significant because it ascertains OT's effectiveness in

accounting for borrowing in Ekegusii. To a large extent, OT accounted for borrowing in terms of the phonological adaptations in borrowed segments in Ekegusii, the phonological processes that influence the sound patterns of the borrowed segments in Ekegusii and different phonotactics that Ekegusii puts in place to militate against alien structures and lastly the morphological and morphotactics of Ekegusii borrowing.

1.7 Scope and Limitations of the Study

The study sought to examine the morphophonology of borrowed segments in Ekegusii using Optimality Theory. The study's scope only covered borrowed segments from English. Words borrowed from other languages were not the focus of the study. This is because English has an elaborate inventory and a complex syllabic structure unlike Ekegusii which is an open syllabicity language with a lean inventory.

Secondly, the study limited itself to a morphophonological analysis of Ekegusii borrowed segments. Other linguistic aspects like syntactic, semantic, pragmatic and sociological which indeed have an impact on borrowed segments were not within the scope of the study. Besides, etymological considerations like the origin of the English loans and the evolution of sounds in the borrowing language were not within the study's scope because the study's focus was the surface representations of the input and output forms of the loanwords which answered the questions the study sought to answer. Also, the study was synchronic in nature focussing on borrowed segments at the time of the study. While tone is a prosodic unit that is typical of Bantu languages like Ekegusii, the study did not embrace its analysis in Ekegusii borrowing. This is because the study's

focus was on the modification of segmental units which were crucial in answering the questions the study sought to answer.

Thirdly, as far as the research methodology was concerned, the study used a descriptive linguistic fieldwork approach. The research instruments which were used are interviews and a wordlist. Further, data collection for the study was limited to spoken data which was elicited from interviews and written data from a wordlist which was compiled from the Ekegusii dictionary and supplemented by introspection. Lastly, in terms of theory the study used only Optimality Theory as proposed by Prince and Smolensky, 1993 and revised in 2004 and Kager (1999) as well as Generalized Alignment Theory by McCarthy and Prince (1993a) which is a sub- theory within OT.

A major limitation to the study was the influence of education on the adaptations of borrowed words in Ekegusii since articulations were key in identifying the sound mapping and phonological as well as morphological processes. This is because formal education enables speakers to acquire sounds that are not in their inventory, therefore affecting modification of loanwords. However, the researcher overcame this by employing adult native speaker competence in instances where the realizations of the sound patterns did not correspond to the Ekegusii phonotactics or morphotactics.

1.8 Chapter Summary

This chapter has discussed the background to the study, foregrounded the statement of the problem, outlined the research objectives, the research questions and the research

assumptions. Also presented is the justification for the study as well as scope and limitations of the study.

CHAPTER TWO

LITERATURE REVIEW AND THEORETICAL FRAMEWORK

2.0 Introduction

This chapter covers the literature on phonemic inventory for both vowels and consonants, prosody and morphology of Ekegusii as well as the inventory, prosody and syllabic structure of English. Thereafter, literature on phonological adaptations in borrowed segments, phonological processes that shape the patterns of borrowed segments, language phonotactics that constrain borrowing and morphological adaptations and morphotactics as well as literature on the Optimality Theory are explicated.

2.1 Literature Review

Relevant related literature that is reviewed in this section encompasses phonological adaptations in borrowed segments, phonological processes, phonotactics, morphological adaptations and morphotactics that constrain borrowing. This review helped the researcher to identify gaps that the study filled.

2.1.1 Ekegusii Phonemic Inventory and Prosody

Ekegusii language orthography has five vowels, namely: *a, e, i, o, u*. However, it has seven vowel phonemes as follows: /a/, /ɛ/, /e/, /i/, /ɔ/, /o/ and /u/ (Nyakundi, 2010). The Figure below presents the vowel positions in the vowel trapezium.

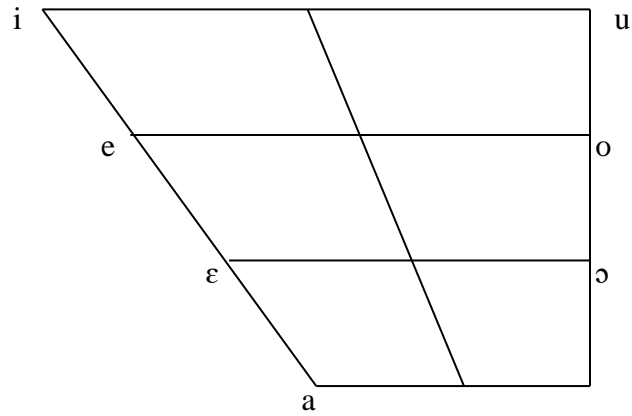
Figure 2.1: Ekegusii Vowel Chart

(Whiteley, 1960, p.2)

On the other hand, Ekegusii has twenty consonants.

Table 2.1: Ekegusii Consonant Phonemes

MANNER \ PLACE	PLACE						
	Labial	Dental	Alveolar	Alveo palatal	Palatal	Velar	Glottal
Plosives			t	c		k	
Prenasalized stops	^m b		ⁿ t, ⁿ d	ⁿ c		^ŋ k ^ŋ g	
Fricatives	β		s, ⁿ s			ɣ	
Nasals	m		n		ɲ	ŋ	
Approximants	w				j		
Liquids			r				

(Source: Mose, Mwangi and Njoroge, 2013: 114)

On Ekegusii prosody, Bickmore (1997) observes that Ekegusii exhibits both the lexical and the grammatical tone. Lexical tone is used to differentiate meaning between lexical items while grammatical tone is used to mark tense. He further identifies three tone patterns; high, mid and low. Whereas tone is a major determinant for both grammatical and lexical aspects of the Ekegusii native words, the study did not envisage that tone could have an impact on the adaptation of borrowed segments. However, its impact could be investigated as it is one of the areas this research recommended for further study.

2.1.2 Ekegusii Morphology

Ekegusii uses a morphological system of prefixes. Words exhibit both free and bound morphemes. Research on Ekegusii noun morphology indicates that they are entered in a system of pairs of prefixes that mark semantic-syntactic categories of singular and plural forms (Cammenga, 2002). Of these pairs of classes, one prefix marks the singular form of the noun to which it is prefixed while the other marks the corresponding plural. Whiteley's early research of 1956 indicated that Ekegusii had 16 noun classes while Cammenga (2002) revised the classes to 21 (details of these classes are presented in Chapter, 5). The study examined how the borrowed segments are adopted to the Ekegusii morphology, particularly the way they are integrated to the various Ekegusii noun classes and how this determines the mapping, the inflectional and derivational morphology of the borrowed segments and how it is constrained as well as the morphological processes and how they too are constrained by OT's markedness and faithfulness constraints.

2.1.3 Structure of RP English

English has five long vowels: /u:/, /ɜ:/, /ɑ:/, /ɔ:/ and /i:/; six short vowels: /ʊ/, /ɪ/, /e/, /æ/, /ʌ/ and /ʊ/; eight diphthongs: /ɪə/, /eə/, /ʊə/, /eɪ/, /aɪ/, /ɔɪ/, /əʊ/ and /aʊ/; five triphthongs: /eɪə/, /aɪə/, /ɔɪə/, /əʊə/ and /aʊə/ which give a total of twenty four vowels. On consonants, it has twenty-four. They are: /p/, /b/, /t/, /d/, /k/, /g/, /f/, /v/, /θ/, /ð/, /s/, /z/, /ʃ/, /ʒ/, /dʒ/, /h/, /m/, /n/, /ŋ/, /r/, /l/, /j/ and /w/ (Roach, 2009).

Kris'to (2000) notes that in English, primary stress is quite variable: it may be placed on first syllable like in *'sister*, second; *att'ention*, third; *deco'ration* and fourth; *exaspe'ration*. Additionally, for nouns stress can fall on the penultimate or antepenult syllable depending on the weight of the syllable and the degree of phonological conditioning which is sometimes overridden by morphological factors. A case in point is the suffixes like *-ic*, that attract the stress on the immediately preceding syllable like; *syll'abic*, while other suffixes are neutral like *-ing*, in *'decorating*, *-ed*, *'decorated*, *-ly*, *'colourfully*. Moreover, others attract stress to themselves like *-ée*, *refer'ee*. Yet, other prefixes like *per-*, *o-*, may interfere with the stress of the stem so that one realizes *per-'mit*, *o-'mit*, when ordinarily verbs with a light ult are generally stressed on the penult. With this elaborate stress placement for the English language, the current study did not delve into how borrowed segments bearing stress are adapted in the Ekegusii language which is tonal. Rather, the focus of the study was the English's syllabic structure and its impact on Ekegusii borrowing. Further, Roach (2009) adds that, English has a complex syllable structure that allows up to three cluster consonants at the onset and up

to four at the coda. Ekegusii on the hand has an open and simple syllable structure that does not permit cluster consonants as well as coda. The study examined how repairs are introduced in Ekegusii so as to take care of the complexity in the syllable of the English borrowed segments.

2.1.4. Phonological Adaptations of Borrowed Segments

Research on loanword phonology indicates that borrowed segments tend to undergo systematic adaptation which involves phonological structures at various levels and one of these levels is segmental. The literature review presented herein examines the adaptation at the segmental level in an attempt to situate a linguistic gap this study sought to fill.

Kambuziya, Hashemi, Aghagolzade and Golfam (2014) examine the phonological adaptation of Arabic loanwords in Persian focusing on consonants. They gather 700 Arabic loanwords from Persian Dictionary, then extract the phonemic forms of loan words from two Arabic dictionaries. Using the optimality theory, they found that the interdental, pharyngeal and bilabial glide places of articulation are not active articulators in Persian. As a result, Persian language speakers will replace loanwords containing these consonants with those that are very close in terms of place of articulation. Thus, the alveolar Persian fricatives /s/ and /z/ replace the Arabic interdentals /θ/, /ð/ respectively, while the voiced uvular fricative /ʁ/ is adapted as the voiced uvular plosive /g/, the voiceless pharyngeal fricative /ħ/ is adapted as the voiceless glottal fricative /h/, the bilabial glide /w/ is realized as labiodental /v/ and

finally, the pharyngeal fricative /ʕ/ is adapted as the glottal plosive /ʔ/. Although the study uses Persian and two Arabic dictionaries as sources of data and OT has been used to account for the sound adaptations in Persian, the phonological processes which result from the sound changes are not covered.

Silverman (1992) using a rule based comparative model notes that English consonants are replaced by those in close correspondence in Cantonese in that the English /b/ is replaced by Cantonese /p/ while /d/ is replaced by /t/. On the other hand, consonant clusters from English are preserved via vowel epenthesis. The prosodic features of English like stress is mapped to Cantonese tones resulting to a stressed syllable being assigned a high [H] tone, medial unstressed syllable is assigned middle [M] tone and the epenthetic syllable in non-final position is assigned a low [L] tone. Hence, these adaptations at various levels collaborate to enable the adapted segments to satisfy both the native language phonotactic requirements and at the same time maintain similarity with source pronunciation. Though Silverman's study investigates how English consonants are mapped to Cantonese, the study is based on the rule based comparative model under generative phonology while this study adopted a constraint-based approach.

Miao (2005) using OT studies loanword adaptation in modern Mandarin from a corpus based on three languages: English, German and Italian. He observes that, there is both faithful preservation and deviant output in Mandarin Chinese. When mapping patterns, articulatory features of manner for consonants show differential changeability and are

likely to be maintained than other features like voice, place and aspiration. The English voiceless bilabial plosives /p/ and /t/ are replaced with Mandarin aspirated plosives /p^h/ and /t^h/ respectively. Also, illegal syllable structures undergoing phonotactic adaptations display variation between preserving consonants via vowel epenthesis and deletion, although in most instances, retention is preferred to deletion. The alveolar stop /d/ at coda position in English is adapted as /t/ in Mandarin along with vowel epenthesis. Sometimes a deviant output is realized when /t/ is realized as /ts/. Miao's study accounts for borrowing in Mandarin exploring not only the sound patterns, but also the phonological processes which are accounted for using OT. Miao's study guided this current study on three aspects; theory application, sound adaptations and description of phonological processes in Ekegusii borrowing.

Faezeh and Zafaranlu (2013) carried out a study on the mapping of German diphthongs in Persian loanwords using Prince and Smolensky's (1993) Optimality Theory. They select 30 German loanwords as research data through the library method from written resources and the rest are the trade names of German Products that are collected through a field work. A descriptive analysis of the data is done. The findings reveal that diphthongs are changed to simple vowels in Persian language. For instance, the back, lax vowel in German loanwords is changed to the back, tense vowel /o/ in Persian language. The front round vowels are changed to back round vowels, indicating that roundness feature overrides the fronting feature. They further note that there is no schwa in Persian, thus, it is simply realized as /e/. On the adaptation of consonants, Faezeh and Zafaranlu note that the velar fricative consonant /x/ in German is substituted

with the uvular fricative /ʁ/ in Persian language; the palatal fricative consonant /ç/ in German changes to the palate alveolar fricative /ʒ/ in Persian language. The velar nasal consonant /ŋ/ in German, is substituted with the consonant cluster [ŋj] in Persian. Faezeh and Zafaranlu's study guided this study on theory especially on the application of OT to account for sound adaptation and data collection whereby research data from written Ekegusii sources were sought. However, the language families are very different; hence, the need for the current study.

Obiala (2008) notes that Polish speakers devoice coda obstruents in their acquisition of the English language. English obstruents like /b/, /g/ or /d/ ordinarily maintain their voice status, however for Polish speakers, they devoice and this is the challenges they face. This study may be on acquisition but the challenges the Polish speakers face are not unique to Ekegusii borrowing which also witnessed obstruent devoicing.

Mogaka (2009) found that when Ekegusii adopts Kiswahili loans, the high front unrounded vowel /i/ changes to the mid-high front unrounded vowel /e/ while the back high round vowel /u/ is changed to the high front unrounded vowel /i/. Similarly, the back high rounded vowel /u/ changes to the mid-high back rounded vowel /o/ while the mid-low back unrounded vowel /ɔ/ is adapted as /u/. In some instances, the mid-low back unrounded vowel /ɔ/ changes to /i/. The substitution of one vowel and not the other depends on the phonological environment and there is no direct mapping even when the same vowel exists in Ekegusii. On the adaptation of consonants, Mogaka observes that the bilabial fricative /β/ in Ekegusii is adapted in place of the voiceless bilabial stop /p/,

the labiodental fricatives /f/ and /v/ respectively. The voiced alveolar fricative /d/ is replaced by its voiceless counterpart /t/ while voiced palatal fricative /dʒ/ changes to the voiceless palatal plosive /c/. The lateral approximant /l/ on the other hand is adapted as the alveolar trill /r/ while the voiceless velar stop /k/ is adapted as voiced velar fricative /ɣ/. Still on the consonants, the voiceless interdental fricative /θ/ changes to the voiceless alveolar stop /s/ or the voiceless alveolar stop /t/, while the voiced interdental /ð/ simply changes to /t/. On stridents, /z/ is adapted as /s/, the voiceless post alveolar fricative /ʃ/ as /s/, while /nz/ changes to /ns/. Lastly, the homorganic sounds /ndʒ/ is adapted as /ⁿc/ and /nd/ as /nt/ respectively. This study presents how the Kiswahili sounds are adapted to Ekegusii, Mogaka hardly pays attention to the underlying phonological processes.

2.1.5. Phonological Processes that Shape the Patterns of Borrowed Segments

The literature review discussed herein examines the phonological processes that occur during adaptation at the segmental level and syllabic as a result of differences in the languages' phonology. By examining the phonological processes that segments and syllables undergo, the study situates the linguistic gap this study filled.

Iribemwangi and Karuru (2012) do a study on borrowing of the Gĩ-Gĩchũgũ dialect of Gĩkũyũ language from Kiswahili. Using the Source-similarity model, they establish that Gĩ-Gĩchũgũ in the adaptation of consonants it employs deletion, preservation, substitution and importation. Conversely, in the adaptation of vowels the phonological

processes reported include insertion, preservation and substitution. These phonological processes ensure that the borrowed segments are as similar as possible to the source forms. Gĩ-Gĩchũgũ dialect of Gikuyu is a Bantu language just like Ekegusii. There was need therefore to establish if Ekegusii reported similar phonological processes when borrowing from English. Besides, Iribemwangi and Karuru's study was guided by Source- similarity theory while this study was guided by OT.

Saleh and Jarrah (2013) study English loanword phonology in Madin Hijazi Arabic (MHA) using a list of two hundred loanwords. They established that phonological changes observed include: epenthesis, consonant voicing, vowel change and re-syllabification so as to maintain the MHA phonological structures. Similarly, Zafaranlu and Hashemi (2011) using OT report that: insertion, prothesis, no palatalized consonants and no noun ending in the central low short vowel [a] are the phonological processes reported on Russian loanword adaptation in Persian. In addition, Faezeh and Zafaranlu (2013) using OT observe that initial consonant clusters of German loanwords are broken through vowel epenthesis which is mostly identical to the vowel of the second syllable and reduction in diphthongs as well as the substitution of phonemes. Madin Hijazi Arabic and Persian are very different from Ekegusii language; thus, it was necessary to establish whether Ekegusii phonological processes can be accounted for in reference to the languages mentioned. Nevertheless, the two studies guided this study in accounting for the phonological processes observed in Ekegusii borrowing using OT.

Sarkar (2012) notes that loanwords undergo phonological changes at two levels: segmental level and syllabic level. At the segmental level, loaned consonants in the onset and coda positions undergo two processes; deletion and substitution. At syllabic level, compensatory lengthening, consonant deletion, feature change, vowel epenthesis, cluster tolerance and germination are the phonological processes reported in Bangla. Equally, Ayuni (2012) notes that the most frequent phonological process is epenthesis followed by change of sound strength and deletion. Ayuni further observes that dissimilation and metathesis are infrequent processes that happen in the Indonesian borrowed words. Though Ayuni and Sarkar's studies are on Southern Asian languages, they report various phonological processes that are accounted for using the constraint based approach. These phonological processes needed to be ascertained in Ekegusii borrowing.

Fossi (2012) does an analysis of English loanwords in Ngəmbà, a Bantu language spoken in the West Region of Cameroon. The corpus of 249 loanwords collected through interviews and participant observation of Ngəmbà speakers aged between 16 and 83, living in rural and urban areas was used. The descriptive model is the framework used for the data analysis. The findings reveal that borrowed words undergo: cluster simplification, consonant vowel reinterpretation, schwa deletion, voicing, devoicing and tone insertion. This study guided our analysis of Ekegusii loanwords in terms of ascertaining the phonological processes. However, this study departs from our study in that it is not based on any theoretic perspective while our study is OT based.

Fossi' findings on phonological processes are somewhat similar to those that Chacha (2009) reports in his analysis of loanwords from Arabic to Kiswahili which are: vowel epenthesis to repair syllables, feature change, consonant deletion and cluster tolerance. Chacha further adds that Kiswahili's open syllabicity (NOCODA) faithfulness constraint dominates the markedness of the sonority hierarchy (SON-SEQ) in the borrowed words. Though Kiswahili is Bantu, Chacha notes that it is prone to consonant clusters within syllables because of its long-time association with non-Bantu languages (English and Arabic), leading to the realization of cluster tolerance. Chacha's study on the integration of Arabic loanwords in Kiswahili guided our study on theory and data analysis. However, as he points out Kiswahili has unique features like consonant clusters which are not typical of Bantu languages.

2.1.6 Language Phonotactics that Constrain Borrowing

Literature on loanword phonology indicates that language phonotactics which is concerned with the freedoms and restrictions that languages allow in terms of syllable structure, which sounds can precede and follow one another, determines linguistic borrowing. The literature review explicated herein is on language phonotactics and how they constrain borrowing in a bid to establish the linguistic gap this study sought to fill.

Kadenge and Mudzingwa (2012) study English loanwords by monolingual and bilingual speakers of ChiShona, a southern Bantu language spoken mainly in Zimbabwe. The study explains that while English has complex syllable structure, ChiShona has simple

one. Besides, there are three major differences pointed out in the study: firstly, ChiShona allows open syllables only while English has closed syllables. Secondly, ChiShona does not allow complex onsets while English can have as many as three consonants in the onset position. Thirdly, ChiShona does not permit complex syllable nucleus while English allows long vowels and diphthongs in its syllable structure. In Kadenge and Mudzingwa comparison, the findings reveal that monolingual loanwords are completely assimilated to suit the ChiShona phonological structures while in the speech of bilinguals some marked features of the English language such as complex onsets, the lateral approximant and postnasal voiceless obstruents are retained. Closed syllables and diphthongs are disallowed by both monolinguals and bilinguals whereby they repair through vowel epenthesis and spreading. The study concludes that monolinguals and bilinguals have different constraint hierarchies; while monolinguals rank markedness constraints higher than faithfulness constraints the reverse is true for the bilinguals. This study provided insights to the analysis of Ekegusii borrowing especially in highlighting the donor and recipient language phonotactics. Nonetheless, the new dimension it gives of monolingual and bilingual speakers was beyond the scope of the study.

Ndambuki (2013) is another study that is very similar to our study in theory and objective. He does a constraint-based analysis of Kikamba nativized loanwords. Ndambuki brings to the fore the fact that Kikamba has open syllables and does not allow consonant clusters in the onset whereas English has closed syllables and allows consonant clusters in both onset and coda positions coupled with different phonemic

inventories. His findings reveal that the high-ranked markedness constraints in Kikamba trigger the repair strategies in order to increase the well-formedness of the surface forms. To deal with disallowed codas and consonant clusters, three main strategies: insertion, deletion and feature change are used to satisfy high-ranked markedness constraints in Kikamba. Though on Bantu borrowing, more so Kikamba, Ndambuki's study differs from our study in that he mainly focuses on phonological processes and rarely pays attention to the sound adaptation patterns; this is a gap this study filled.

Btoosh (2006) does a constraint-based analysis of Jordanian Arabic phonotactics using OT. He uses a corpus drawn from the spoken variety of Karak Arabic. He argues that Jordanian Karak Arabic has opacity in word final, adheres to complex codas, non-geminate complex codas and has an ultra-heavy syllable. He further confirms that the language adheres to faithfulness constraints and processes like syncope and epenthesis. Aljumah (2008) examines the syllable structure of Al-Ahsa a dialect of Arabic spoken in the eastern province of Saudi Arabia. Using native speaker competence, Aljumah generates data that he analyses using the optimality theory. He observes that Al-Ahsa prohibits initial consonant clusters but allows complex codas which are analysed as dominated moras. Both Btoosh and Aljumah studies are on Arabic. Besides, Al-Ahsa's syllabic structure prohibits onset consonant clusters but allows consonant complex codas. Btoosh and Aljumah's studies focus on the syllabic constraints. They guided this study in establishing how Ekegusii's open syllabicity constrains borrowing.

Harb (2014) does a study in Hawaiian borrowing from English using the Optimality theory approach. Data for the study consisted of some randomly selected Hawaiian words which were examined to reveal the phonotactics. Harb establishes that in Hawaiian, onset is optional and if it occurs, maximally one consonant is allowed, initial consonants clusters are prohibited, nucleus is obligatory (either short or long) and codas are strictly prohibited. On markedness, Harb formulates the *CC: complex onset is disallowed and *NO CODA: codas are prohibited constraints. On the faithfulness constraints he formulates, MAX-IO: no deletion of segments, MAX-V: no deletion of vowels, MAX-C: no deletion of consonants, DEP-IO: no addition of segments, DEP-V: no addition of vowels and DEP-C: no addition of consonants. Harb establishes that markedness constraints override faithfulness in Hawaiian. Whereas OT accounts for the syllabic structure, this needed to be established in Ekegusii whose syllable structure displays similarities with Hawaiian in that onset is optional and if it occurs maximally one consonant is allowed, initial consonants clusters are prohibited and nucleus is necessarily a vowel.

Green (2002) points out that Burmese prohibits both vocalic and consonantal place features from the right edge of a syllable. Further, Burmese bans diphthongs in open syllables. On prosodic features, Green notes that when adjustments occur to the syllable there is evident syllable reduction manifested in loss of tone, reduction of all vowels, loss of coda consonants and onset simplification. Though Green's study uses OT to account for the syllable structure of Burmese, the study does not highlight how the syllable structure constrains borrowing.

Anyona (2016) does a syllabic nativization of English loanwords into Ekegusii using OT. He notes that Ekegusii maintains CV structure when nativizing words while repairs to illicit structures are done via vowel epenthesis. Some of the constraints he posits that constrain the syllable adjustments include: *COMPLEX C, *COMPLEX^{vow}, Faith C, Faith V, IDENT-IO (F), INDENT-IO (place), MAX- IO, DEP- IO, NO-CODA and ONSET. Whereas this study is similar to the current study in that it focuses on the syllable adjustments when nativization occurs, there are a number of aspects that affect borrowing that Anyona excludes in his study. These include specific sound adaptations, phonotactics of Ekegusii language, morphological adaptations and morphological constraints that constrain Ekegusii borrowing from English.

2.1.7 Morphological Adaptations and Morphotactics that Constrain Borrowing

Oh (2012) investigates the degree to which morphological information affects initial perception of the incoming loanwords. Specifically, he investigates the adaptation of complex English words. He establishes that each component of a complex word is a unit for loanword adaptation. In other words, there is whole borrowing whereby a morphologically complex word is not borrowed as a single unit instead each component word is parsed and adapted separately and independently. Though on adaptation of complex words, this study guided the current one in establishing how the borrowed words were mapped to Ekegusii.

Mira and Syejeong (2012) investigate the morphological effects in loanword adaptation of the English plural suffix into Korean. They established that /z, s/ in a monomorphemic word final are always mapped to the perceptually closest sounds along with vowel epenthesis. However, when they are morphemic, that is denoting the plural they can be deleted. They argue that the morphological structure of the suffixed words plays a role in loan adaptation. This study guided our discussions on the Ekegusii inflection specifically how loanwords inflect for number.

Saidat (2011) investigates how English loanwords are integrated into Jordanian Arabic and the morphological modifications they undergo through inflections on gender and number. Saidat notes that the English loanwords follow the Arabic gender and number inflection rather than English inflection. Saidat's study guided our study on the discussions on the inflectional morphology of Ekegusii borrowed segments as we discussed number and gender. However, while Jordanian Arabic loans inflect for gender Ekegusii loans did not.

Another study in Jordanian Arabic is Mathkour (2012) who examines morphological transformations in respect to gender, number, possession, and the definite article of English loanwords. He notes that when English words are integrated into the Jordanian Arabic, they are assigned either to the feminine gender through the suffixation or to the masculine gender with the absence of any overt gender marking. Furthermore, loanwords in Jordanian Arabic inflect for number: singular, plural and dual. Mathkour concludes that the morphological analysis of loanwords in Jordanian Arabic shows that

such loanwords are treated as if they are Arabic words since they are assimilated in the recipient language.

Fatimah and Abdulmohsen (2017) investigate the morphological adaptation of English loanwords into Kuwait in the Twitter platform. They established that there is no one on one mapping of the English allophones that mark plural. Instead Kuwait has [a:t] which is suffixed to the loanword to mark plural. On the definite article before the English nouns they note that it is prefixed /ʔil/ and mostly contracted to /l/. They also investigate other grammatical categories like the adaptation of English possessive pronouns and prepositions but relevant to our study are the morphological processes that loanwords undergo in Kuwait which include: conversion and clipping. Similarly, our study sought to establish morphological processes in Ekegusii borrowing.

Wiltshire (2003) studied and reported how Yapese, a Micronesian language establishes morphological constraints. She argues that languages may require words to end in consonants, although syllables are under no such obligation and may in fact obligatorily be vowel-final. Using OT, she formulates constraints: ALIGN-R(PW,C) and Max-IO(V) to help her account for the loss of the word final vowel in Yapese. Similarly, she studies another language Pitjantjatjara spoken in Australia which is a converse to Yapese. In Pitjantjatjara, words are required to end in vowels although word-medial syllables may have a coda, but only vowels are permitted word-finally. To account for the tolerance of the codas word mid she ranks the constraints as: ALIGN-R(PW,V), MAX-IO(C) >> DEP-IO(V) >> ALIGN-R(σ,V). This study guided our formulation of

morphological constraints to account for morphological adaptations of Ekegusii loanwords, inflectional and derivational morphology and morphological processes.

2.2. Theoretical Framework

The study used Optimality Theory that relies on the concept of constraint interaction. The constraints interact to select optimal forms depending on how a specific language ranks these constraints. Similarly, McCarthy and Prince's Generalized Alignment in the framework of Optimality Theory was used.

2.2.1 Optimality Theory

Optimality Theory is a constraint-based approach whereby requirements are imposed on the surface form and any form that does not comply is rejected in favour of the one that does. It was first proposed by Prince and Smolensky (1993) and further revised in 2004. The theory proposes that the grammar of all languages have a set of universal constraints which are part of Universal Grammar or the innate language knowledge that humans have. Since the constraints are universal, there are two important features of the theory that explain why languages, nevertheless, have different phonologies. First, languages differ depending on the significance they attach to various constraints. Thus, the phonology of a particular language is determined by how a language ranks a set of universal constraints which results to a language's constraint hierarchy. Secondly, constraints may contradict each other, therefore, they will be violated.

How then does OT determine what output form must be? For any given input form, there will be initially an unlimited set of output forms. This free generation of potential output forms is taken care of by a function called GEN (for generator), which is subject

only to very general constraints of well- formedness. So that if you have a word like *kiss* and you are pluralising it, some of the generated outputs will be [kisiz], [kisz], [kis], [kizz] even [siks]. Out of these several outputs how do you arrive at the optimum? There are two general forces at work that determine which of these numerous potential output forms is chosen by a language. They are markedness and faithfulness universal constraints.

Markedness constraint comes from the idea that all types of linguistic structures consist of ‘marked’ and ‘unmarked’ values. The unmarked values are cross-linguistically preferred and basic in all grammars, while the marked values are cross-linguistically avoided and used by grammars only to create contrast (Kager, 1999). For instance, all languages have open (V, CV) syllables which are unmarked with respect to closed syllables (CVC, VC). Thus, markedness constraint named NOCODA is formulated to ensure syllables have no codas. Another example, all languages have unrounded front vowels such as [i] and [e] but only few languages have rounded front vowels such as [y] and [ø]. Thus, the unmarked value of the distinctive feature [round] is [-round] for front vowels. Therefore, the notion of markedness is inherently asymmetrical as some structures or segments are preferred over others. The following are some universal markedness constraints presented by Kager (1999:9)

- (a) Vowels must not be nasal
- (b) Syllables must not have codas.
- (c) Syllables must have onsets
- (d) Obstruents must not be voiced in coda position

(e) Obstruents must be voiced after nasals

(f) Sonorants must be voiced

The other force as already mentioned that constrains or counterbalances markedness is faithfulness. It is a force which demands that the output form is identical to the input. In other words, the output form must be faithful to the input form so that no changes are allowed. Again, if the faithfulness constraints are ranked above all phonological constraints, no phonological adjustments will be made on the input. By extension, languages will not adapt borrowed words instead the inputs will be similar to the outputs.

However, typically one or more markedness phonological constraints are ranked above one or more faithfulness constraints; which means that in case of a conflict, the markedness phonological constraints wins. Every constraint that is inspected will throw out a number of candidate forms and this process goes on until there is only one candidate left. OT thus holds that the output form is the Optimum form; the form that is left as the only survivor of all candidate forms after an inspection of the constraint hierarchy.

McCarthy and Prince (1995) propose three important constraints to express faithfulness. Firstly, MAX-IO requires that each segment in the input ('I') has a corresponding segment in the output form ('O'). In other words, the input is 'maximally' represented in the output and the constraint is therefore violable if any segment is deleted. Secondly,

DEP-IO which requires that each segment in the output form has a corresponding segment in the input form. That is, the output must be entirely ‘dependent’ on the input and the constraint is violated if segments are inserted. Thirdly, IDENT(F) which requires that every feature (F) in the input segment is ‘identical’ to every feature in the output segment. So, this constraint is violated if a segment in the output changes in terms of features like a change from voiceless to voiced. In the examples we gave earlier: [kizz] and [siks] outputs are unlikely to survive the evaluation by faithfulness constraints, which will quickly see to it that they are discarded in favour of better deserving candidates.

Whereas markedness pays attention to the output form, faithfulness constraints focus on both input and output (Kager, 1999). Here are some of the examples of faithfulness constraints as simplified by Kager (1999:10).

- (a) The output must preserve all segments present in the input.
- (b) The output must preserve the linear order of segments in the input.
- (c) Output segments must have counterparts in the input.
- (d) Output segments and input segments must share feature value for [voice].

In sum, markedness and faithfulness constraints are inherently conflicting. This means that markedness constraints demand well formedness of structural markedness of output representation while faithfulness constraints demand that output representation is similar to the input (underlying representation). To find the optimal output, these constraints are violable. The output may satisfy one and not the other which means that it may not meet the structural requirement of both constraints at the same time. The stronger constraint

is satisfied at the expense of the weaker. The violation of a high ranked constraint is more serious than the violation of low ranked constraints. Thus, grammars of languages regulate conflicts between universal constraints to choose the most harmonic or optimal output form and OT supports that to satisfy one constraint implies the violation of another.

To choose the optimal output requires the operation of evaluating all possible output forms generated by the function GEN (generator) and another called EVAL (evaluation). This evaluation is shown in a *tableau*. The constraints are arranged in columns and the forms to be evaluated are arranged in rows. The input to be evaluated is given on the top left corner. A* in a cell indicates the form of that row breaks the constraint in that column and *! indicates that such violation eliminates that form from further evaluation, in other words the violation is fatal. An optimal form, the winner is marked by ☞. Shaded cells indicate that the constraint in that column has become irrelevant to the fate of the form in the row concerned. Solid vertical line indicates domination while a dotted line shows that the constraints do not dominate each other. Lastly, double solid lines enclose candidates and constraints.

For instance, we can use the plural of ‘kiss’ given earlier to illustrate. The function GEN will take care of generating possible candidates which can be: [kɪsɪz], [kɪs], [kɪzɪz], [kɪss] even [kɪsɪs]. Looking at the inputs, it is clear that the English language attaches a lot of importance to obeying a sibilant following another than obeying the

faithfulness constraints that demand similarity between input and output form like MAX-IO_{SEG}. In order to avoid adjacency of [s] [z], a segment [i] is inserted between them. The output violates OCP_{SIB} which bans the occurrence of similar adjacent segments. Similarly, DEP-IO(V/C) which disallows insertion is relevant. It is also clear the language is less concerned with *voice- voice, therefore, IDENT-IO_{VOI} which demands that faithfulness between output and input in terms of feature change is invoked to evaluate the input further. The constraints are ranked as follows: *OCP_{SIB} >> MAX-IO_{SEG} >> IDENT-IO_{VOI}, DEP-IO(V/C).

(2.2) /kɪs/ → [kɪsɪz]

/kɪsɪz/	*OCP _{SIB}	MAX-IO _{SEG}	IDENT-IO _{VOI}	DEP-IO(V/C)
a. ↗ [kɪsɪz]			*	**
b. [kɪs]		*!		
c. [kɪzɪz]	*!		*	**
d. [kɪss]	*!			
e. [kɪsɪs]	*!			**

Candidate (a) is the most harmonic. It only violates the low ranked DEP-IO(V/C) by allowing vowel insertion and IDENT-IO_{VOI} since there is feature change. On the other hand, candidate (b) is eliminated on account that it violates MAX-IO_{SEG} which has deleted the plural suffix. Though it is a faithfulness constraint it appears the language ranks it higher although it is dominated by markedness constraint. Candidate (c) is the most disharmonic. It not only violates the high ranked markedness constraints*[OCP_{SIB}] which disallows occurrence of similar adjacent segments but also the low ranked

faithfulness constraints IDENT-IO_{VOI} which prohibits feature change and DEP-IO(V/C) which disallows insertion of either vowels or consonants. Therefore, it is eliminated. Candidate (e) does not fare well either it violates the high ranked markedness constraint *[OCP_{SIB}] which bans occurrence of adjacent sibilants which the language attaches importance to as well as the low ranked DEP-IO(V/C). Hence, it is eliminated. As for candidate (d), it violates the high ranked markedness constraint *[OCP_{SIB}], the low ranked DEP-IO (V/C) by allowing consonant insertion, as a result, it does not survive.

From the tableau 2.2, as Kager (1999) puts it, ‘perfect’ output forms are principally non-existent as every output form will violate at least some constraints as in the case of [kɪsɪz]. Therefore, the selection of the ‘optimal’ output form involves setting priorities. The higher-ranked of a pair of conflicting constraints takes precedence over the lower-ranked one. Constraints are ranked in a hierarchy of strict domination. This means a candidate that violates only a high-ranked constraint does worse on the hierarchy than one that does not, even if the second candidate fared worse on every other lower ranked constraint. This also means that constraints are violable; the winning candidate need not satisfy all constraints. Within the language, a constraint may be ranked high that is always obeyed; it may be ranked low enough that it has no observable effects or it may have some intermediate ranking.

Next, we take a closer look at how both constraints and both functions of a grammar work in OT. The figure below shows that GEN provides a set of candidates (a, b, c...n). Evaluation occurs by a set of hierarchically arranged constraints (C₁, C₂ ...n), when one

constraint dominates the other, the relation is denoted as $C_1 \gg C_2$. Based on dominance hierarchy, a grammar ranks the universal constraints. The constraints are markedness and faithfulness. Both major constraints will eliminate some candidates and eventually only one output candidate survives. The survivor is the optimal candidate which is the most harmonic with respect to the set of ranked constraints. All less harmonic candidates are ill-formed. In OT as already mentioned, there is no perfect output form since every output will violate at least some constraint. In other words, only one form wins, optimally but never perfectly.

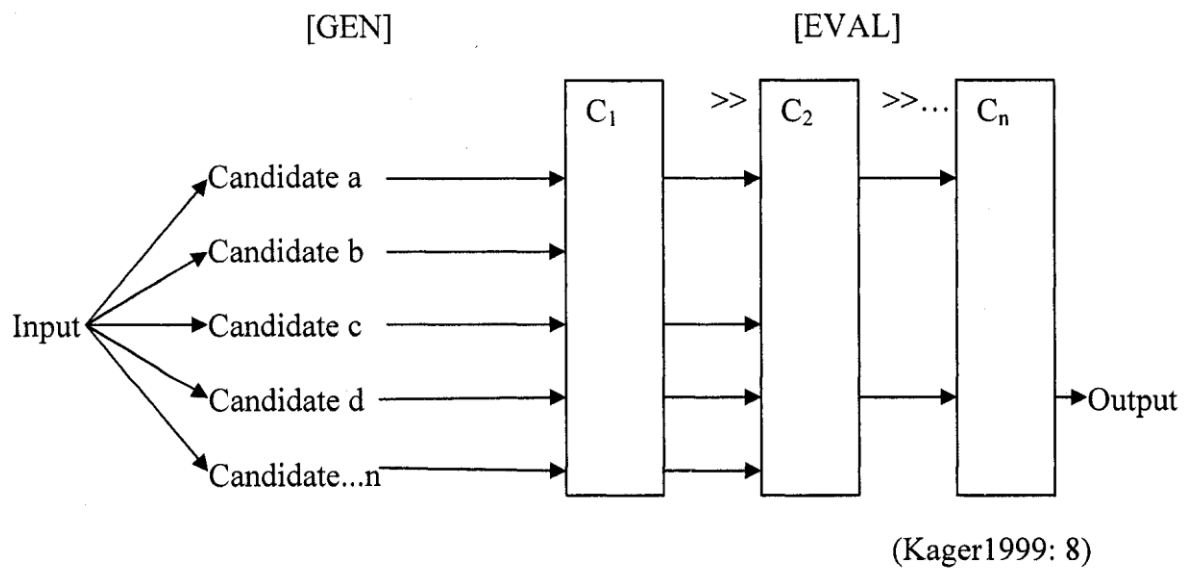

2.2.2 Generalized Alignment Theory

McCarthy and Prince (1993a) proposed Generalized Alignment (GA). It is embedded in OT's constraints of well-formedness of phonological and morphological representations. GA explains the concept that edges of grammatical constituents should

align with corresponding prosodic constituents. The general alignment constraint for GA is presented in schema (2.1) below.

(2.1) Generalized Alignment

$\text{Align}(\text{Cat}_1, \text{Edge}_1, \text{Cat}_2, \text{Edge}_2) =_{\text{def}}$

$\forall \text{Cat}_1, \exists \text{Cat}_2$ such that Edge_1 of Cat_1 and Edge_2 of Cat_2 coincide.

Where $\text{Cat}_1, \text{Cat}_2 \in \text{Pros Cat} \cup \text{Gram Cat}$

$\text{Edge}_1, \text{Edge}_2 \{ \in \text{Right, Left} \}$

Grammatical category consists of morphological categories (Word, Stem, Affix and Root) while Prosodic category has prosodic categories (Mora, Syllable, Foot and Prosodic Word). So, from the schema, quantification of Cat_1 is universal whereas that of Cat_2 is existential, meaning for each Cat_1 there is some Cat_2 . Both the morphological and the prosodic features can be subsumed under a single family of well-formedness constraints as presented in (2.2a and b)

(2.2) a. ALIGN-WD-L: $\text{Align}(\text{PrWd}, \text{Left}, \text{Foot}, \text{Left})$

b. ALL-FT-L: $\text{Align}(\text{Foot}, \text{Left}, \text{PrWd}, \text{Left})$

Constraint (2.2a) states that for each left PrWd edge there is some left foot edge which coincides with it. It is violated by each PrWd which does not begin with a foot. Constraint (2.2b) states that for each left foot edge, there is some left PrWd edge which coincides with it. It is violated by each foot which does not lie at the beginning of a PrWd. Such differences become important in structures which contain multiple feet, or multiple PrWds. Other constraints include:

- (2.3) a. ALIGN (Affix, L, Stem, L),
 b. ALIGN (PrWd, L, Stem, L)

Constraint (2.3a) states that the left edge of the affix must coincide with the left edge of some stem; meaning, it expresses an instance where there is a prefix rather than a suffix. On the other hand, constraint (2.3b) states that each left edge of prosodic word aligns with the left edge of some stem.

In GA theory, there are no derivations by ordered rules, but only well-formedness constraints which evaluate possible output representations. Well-formedness of outputs is taken to be a relative notion. The output selected by the grammar is the one which violates the smallest number of constraints. Crucially, constraints are ranked hierarchically in a language-specific manner, so that lower-ranking constraints may be violated in order to satisfy higher-ranking constraints. All constraints are universal, as well as violable.

Optimality Theory predicts that GA interacts with other constraints, depending on its relative ranking. One expects to find grammars in which an alignment constraint is high-ranked, but can nevertheless be violated in order to satisfy top-ranking constraints. Equally, the same alignment constraint may still be active in selecting the optimal output in cases where higher-ranking constraints make no decision.

GA expresses the full range of reference to edges in grammar, thus was considered appropriate for morphological adaptations. In fact, the specific interpretation of GA as

Align (GCat, PCat) involves simultaneous reference to prosodic and morphological structure. It therefore allows for separate control over the fate of each edge whether it is left or right because conditions on each can indeed have very different grammatical status. In the study, GA was used to account for morphological adaptations in Ekegusii language.

2.2.3 Justification for the Use of Optimality Theory and Generalized Alignment

The basic assumption of Optimality Theory is that constraints are in fact universal and violable. These constraints do not occur in isolation they reside in human languages, meaning that in some languages a constraint may be ranked below another constraint that compels it to be violated (Prince & Smolensky, 1993:5). Since different languages have different phonologies, OT then seems suitable because it recognizes that languages differ in the importance they attach to various constraints.

Secondly and most importantly is what is noted by Gussenhoven and Jacobs (2005) that there are two approaches which can be used to account for phonological adjustments in languages: derivational approach based on rules and constraint approach. The derivational approach is associated with Noam Chomsky and Morris Halle in their book '*Sound Patterns of the English, 1968*'. They present rules that change the phonological representation of the morpheme in a particular context. However, rules are necessarily repetitive and will require constraints to characterize the phonological well-formedness of a segment. To illustrate this, is the rule of 'voice assimilation' in the plural formation

in English which will characterize [bægz] as well-formed and [*tapz] as ill formed. The same rule cannot account for [kis-z] yet it is the same phenomena. In this case, you have to derive another rule of voicing to effect the change from [s] to [z]. This drawback is what Kenstowicz and Kisseberth (1977: 133) call duplication problem. OT does not run into this problem at all since the constraint on English plural formation will act as a constraint on all forms.

Thirdly, in regard to loanword adaptation, a rule-based analysis must add rules to the native grammar that brings the adaptations. By contrast in OT, no such extra grammar would be needed. For instance, Ekegusii language borrows a segment from English which has a complex onset in a noun like ‘*tractor*’. The derivational approach will have to add rules to the native phonology to account for the adaptation. For OT a constrain forbidding complex onsets will apply to meet the structural demands of a language at once. Similarly, OT is a typological theory meant to account for variations among languages through constraint re-ranking. For instance, this study in Ekegusii showed that markedness constraints that demand structural well formedness dominated the faithfulness constrains whereas literature on Kiswahili indicates that it tolerates complex clusters. Thus, the languages though Bantu rank constraints differently yet they borrow from the same language; English. Lastly, GA was selected because it allows for occurrence of affixation in reference to edges in grammar; hence, appropriate for morphological adaptations. Further, GA involves simultaneous reference to prosodic and morphological structure. Though this study did not explore the prosodic level, GA was used to account for morphological adaptations in Ekegusii borrowing.

2.3 Chapter Summary

This chapter has reviewed literature related to the study and identified gaps that the study filled. Specifically, it has reviewed Ekegusii phonemic inventory, prosody and morphology. On the other hand, the structure of RP English was reviewed. Also reviewed were the phonological processes, syllabic phonotactics, morphological adaptations and morphotactics of languages. Lastly, the theories that the study used are

discussed; Optimality Theory and Generalized Alignment as well as their relevance to the study.

CHAPTER THREE

RESEARCH METHODOLOGY

3.0 Introduction

This chapter outlines the research design which was used to attain the study's objectives. Further, the study population, the sample and the sampling procedures are presented. The research instruments are outlined as well as data collection and analysis procedures. Finally, the ethical issues that the research took into consideration are discussed.

3.1 The Research Design

The study employed a descriptive linguistic fieldwork. This is an investigation of the structure of a language by collecting primary data which is gathered by interacting with the adult proficient speakers or written native speaker resources (Chelliah & Reuse, 2011). The study was a morphophonological analysis of borrowed segments in Ekegusii using Optimality Theory. Descriptive linguistic fieldwork painted a picture of the phenomenon of borrowed segments in Ekegusii, as it naturally occurs.

3.2 The Study Population

The ideal study population for a phonetic research is the one that is neither too young nor too old since the latter speakers have less or no control over their articulators. Further, they should be native speakers of the language to be studied, have all their own

teeth and should not have any speech disorders (Bower, 2008). This study targeted Ekegusii native speakers who met Bower's description. The assumption was that native speakers have inherent native speaker competence which detects what is well and ill formed in the language. When speakers are faced with foreign elements like borrowed segments, they report phonological and morphological adaptations that ensure the segments do not violate native language phonotactics and morphotactics.

3.3 The Sample and the Sampling Procedures

Samples are relied upon to represent larger populations since it is not possible to study an entire population (Johnson, 2008). Johnson adds that a good sample should be large enough and randomly selected. However, there are instances he recommends that the maxims of good sampling can be violated. One such given, is when you observe linguistic performance only in a restricted context. For example, respondents are reading a word list or a group of sentences and the researcher is drawing judgement or gauging performance. This study adopted restrictive or selective sampling because adaptation of loanwords by native speakers revealed performance which is by extension adaptation.

The number of respondents a linguistic investigator should strive to obtain for phonological analysis varies. However, a researcher can start with one speaker and then compare results with data from subsequent speakers (Chelliah & Reuse, 2011). When doing a phonetic analysis of sounds, a researcher can use several tokens and several speakers. In fact, Ladefoged (2003) recommends between 24 and 40 speakers who can

be half male and half female. On the other hand, Gordon (2003) approves six male and six female speakers. Cooper and Vaux (2003) simply observe that whether linguists prefer one or more, both have advantages and disadvantages. If one works with one respondent, the data is relatively consistent while many yield idiolect and dialectal differences. Nonetheless, working with many one yields a better, overall, balanced picture of the phenomenon under description. On the other hand, Chelliah and Reuse (2011) recommend that for languages which already have previous wordlists, a linguist can re-elicite between 200-500 words. Bower (2008), notes that in wordlists, one needs enough tokens to produce significant results but not too many because they may bore the research participants. Following these assertions by different authors, purposive sampling was carried out in two stages. First, the researcher sampled two hundred words from Ekegusii dictionary, then supplemented from introspection. Secondly, the researcher chose three adult proficient Ekegusii speakers (two males, one female) respondents who were interviewed to overtly realize the sound patterns in the Ekegusii borrowing process.

3.4 Research Instruments

The study used two research instruments; interviews and a word list. An interview is a conversation between people whereby one person takes an active role of the researcher and the other the interviewee (Grey, 2009). An interviewer prepares a set of written questions beforehand and then poses them in either a structured or unstructured way. Henn, Wemstein and Foard (2006) note that in most cases interviews are very appropriate in situations where the researcher intends to share control with the

respondent in the data gathering process. Thus, the researcher may allow the respondent to come up with his/her own account. The study considered interviews appropriate in order to observe and record various sound adaptations in the Ekegusii borrowed segments.

The researcher used semi-structured, in-depth, one-to-one interview with all the three respondents at different times. Using a wordlist of borrowed segments, the researcher guided the interviewees to articulate the words and the responses were documented by tape recording and note taking. Ladefoged (2003) notes that, describing how people talk requires the researcher to record, transcribe and analyse phonetic data. To enhance validity of the interview, the researcher did not explicitly explain to the respondents what she was looking for when they were articulating the various borrowed segments in Ekegusii. These minimized cases of hyper-correction which otherwise would have compromised the validity of the interview.

Another instrument that was used was a wordlist. It is an essential research instrument for descriptive linguistic fieldwork. It actually forms the basis of interaction between the researcher and native speaker in an interview and its preparation must be done in a careful manner, since it forms the basis of phonetic and phonological analysis (Chelliah & Reuse, 2011). Following Chelliah and Reuse (2011) recommendation that a linguist can re-elicite between 200-500 words, the study generated a corpus of two hundred borrowed words from Ekegusii dictionary. Grey (2009) adds that wordlists can be used to assess what people have learnt in terms of knowledge, skills, comprehension and

above all performance. By implication, borrowing in Ekegusii occurs largely because of external influence. The way proficient Ekegusii speakers adopt borrowed segments was treated as learnt knowledge displayed through performance thus, the appropriate use of word lists. To enhance reliability of the word list, they were subjected to different respondents (three) to ascertain if the sounds realized in the different borrowed Ekegusii segments correlated. Further, through native speaker competence the researcher employed intuition to supplement cases which she felt were not correlating.

3.5 Data Collection Procedures

The study utilized both written and spoken data. Chelliah and Reuse (2011) note that the first step in collecting phonetic data is to collect any previous studies, descriptions or documents on the language to be studied. They can be phonetic and phonological descriptions or texts since the aim is to acquaint one with the sounds in the language, its syllabic structure and phonotactics as well as the supra-segmental features. Thus, they recommend that a fieldworker should prepare a wordlist which should be recorded and transcribed narrowly. The researcher collected data by making a wordlist of loanwords from the Ekegusii dictionary and further supplemented using introspection. Chomsky (1977) refers to this as native speaker competence. Moreover, spoken data was elicited from the interviews using the wordlist, then the interview sessions were recorded. The spoken data enabled the researcher to identify the phonological and morphological adaptations and phonological as well as morphological processes in the borrowed Ekegusii segments.

3.6 Data Analysis Procedures

Data analysis involves breaking down data into small units which can shed light on the characteristic elements (Dey, 1993). Furthermore, analysis is key in that new insights into the data are discovered, inferences made and relationships established. A phonetic data analysis requires the following processes: transcribing the recordings and labelling them, producing metadata and interlinealizing (Bower, 2008). The researcher transcribed the borrowed segments in order to determine the phonological adaptations and the phonological processes. Still, the transcribed data helped the researcher to identify the morphological adaptations and the morphological constraints that Ekegusii imposes on incoming loanwords.

Finally, Abrahamson (1983) underscores the importance of theory by noting that no discussion would be complete without relating the central place occupied by theory and the interplay between theory and research. That every theory tends to contain an abstract statement about how phenomena are related to each other. As such, the phonological and morphological adaptations as well as processes were analysed by first choosing the constraints, then ranking them in the tableaux and determining the optimal forms.

3.7. Data Management and Ethical Considerations

Ethical research broadly defined can be a way of doing research that the researcher and the target language community consider appropriate (Bower, 2008). In linguistics, the ethical considerations include: recording research participants, avoiding inflicting harm,

seeking permission to work on a particular language and observing people and identifying research participants. Moreover, linguistic elicitation requires one to work with humans; therefore, many researchers seek permission from university ethics boards and academic advisors (Chelliah & Reuse, 2011). They further add that ethical considerations extend to acknowledging or honouring data ownership as well as establishing and maintaining appropriate safeguards against disallowed data access. The following requirements were observed to ensure adherence to these ethical considerations in the course of this study: On recording participants and avoiding harm, the researcher sought respondents' consent and scheduled interviews in a way that did not inconvenience them when recording. Secondly, where data and other resources were used in this study, the researcher appropriately acknowledged them. Lastly, the revised proposal was submitted to Graduate School for registration and issuance of permission to carry research. Thereafter, the researcher sought permission to carry research from the National Commission for Science Technology and Innovation (NACOSTI) which was granted.

3.8 Chapter Summary

This chapter has discussed the research design which was used in the study, the study population, the sample and the sampling procedures that were employed. The research instruments that yielded the data used in the study are also discussed. Moreover, the data collection and analysis procedures are elaborated. Finally, data management and ethical considerations relied upon by the research are discussed.

CHAPTER FOUR

PHONOLOGICAL ADAPTATIONS

4.0 Introduction

When borrowing words from English, Ekegusii speakers borrow underlying representations of the loanwords, then their phonological grammar maps the underlying representation into surface representations using the language's phonotactics. However, this mapping hardly escapes adaptation as languages differ in their phonological inventories. Thus, this chapter presents first; the phonological adaptations of borrowed sounds (vowels and consonants), then it describes the phonological processes that shape the patterns of the borrowed segments in Ekegusii and lastly it establishes the phonotactics of the Ekegusii language that constrain borrowing in Ekegusii.

4.1 Adaptation of Vowel Sounds

Vocalic sounds are produced by egressive pulmonic airflow by vibrating or constricted vocal cords in the larynx so that the sounds generated are modified by the cavities of the tract. The size and shape of the tract is varied, just like the positioning of the tongue and the lips so that the perceived phonetic quality of the vocalic sound is altered. Thus, the two most fundamental manoeuvres in producing various vocalic sounds are the shape and position of the tongue as well as the shape and degree of protrusion of the lips (Clark & Yallop, 2007). The data analysed revealed that vowel adaptations generally displays both predictable and unpredictable patterns in the mapping of English vowels to Ekegusii. The discrepancy is not unique since English has twenty four vowels: /u:/,

/ɜ:/, /ɑ:/, /ɔ:/, /i:/, /ɒ/, /i/, /e/, /æ/, /ʌ/, /ʊ/, /ɪə/, /eə/, /ʊə/, /eɪ/, /aɪ/, /ɔɪ/, /əʊ/, /aʊ/, /eɪə/, /aɪə/, /ɔɪə/, /əʊə/ and /aʊə/, whereas Ekegusii has seven vocalic phonemes /a/, /ɛ/, /e/, /i/, /ɔ/, /o/ and /u/ .

4.1.1 The Adaptation of /i/ in Ekegusii

The data revealed that in most of the borrowed segments, the close front unrounded vowel /i/ was mapped to Ekegusii's /i/ as shown:

English Input	Ekegusii Output	English Gloss
/pɪn/	[eβini]	'pin'
/gɪ'tɑ:/	[eɣita]	'guitar'
'tɪkɪt/	[etiɣiti]	'ticket'
/bɪl/	[eβiri]	'bill'

Both the close front unrounded /i/ and the mid-close front unrounded /ɪ/ have shared features [+high, -back, -round] which facilitate the mapping. Closely related is the mapping of the close front unrounded long vowel /i:/ realized as /i/. This too could be explained as the two have similar shared features [+high, -back, -round]. This mapping is illustrated by the following loanwords:

English Input	Ekegusii Output	English Gloss
/ti:'vi:/	[etiβi]	'T.V'
/ti:m/	[etimu]	'team'

Another instance is that of the diphthong /aɪ/ as in ‘biro’ /'bairəʊ/ adapted as [eβiro]. Ekegusii does not have diphthongs just like most Bantu languages. Thus, the /a/ in the diphthong is deleted and the component part of the diphthong /ɪ/ is retained but realized as /i/.

These findings on vowel adaptation in Ekegusii can be accounted for using OT (Prince & Smolensky, 1993; 2004). The theory proposes that the grammar of all languages have a set of universal constraints which are part of Universal Grammar or the innate language knowledge that humans have. However, what differs is the significance a language will attach to these various constraints. Thus, the phonology of a particular language is determined by how a language ranks a set of universal constraints which results in a language’s constraint hierarchy. First, is the markedness constraint which presupposes that languages have ‘marked’ and ‘unmarked’ features. Whereas unmarked features are basic in all grammars and preferred cross-linguistically, marked are avoided cross-linguistically (Kager, 1999).

In order to account for the Ekegusii substitution of /i/ for both the long vowel /i:/ and the diphthong /aɪ/ in English, we invoke the following universal markedness constraints. With no diphthongs in the vowel phonemic inventory of Ekegusii we can posit an undominated anti-diphthong constraint; the markedness constraint *DIPH which prohibits complex nuclei. Similarly, *CODA markedness constraint is not violated in the Ekegusii language, thus, it is relevant. In addition, the English input ‘biro’ /'bairəʊ/ adapted as [eβiro], it can be observed that the bilabial stop /b/ is adapted as the labial

fricative /β/. This can be accounted for by proposing undominated markedness constraint *[b] since the sound is only attested in the Ekegusii language in its prenasalized form- /^mb/. Besides, the markedness constrains, OT proposes faithfulness constraints which demand that the output form is identical to the input. In other words, the output form must be as faithful as possible to the input form. In this regard, the vowels /i/ and /i:/ have shared features [+high, -back, -round] which seem to be constraining the incoming input. So, IDENT-IO_{BACK} can be proposed to evaluate the outputs further. Moreover, IDENT-IO_{DIPH/CONT} which prohibits feature change between input and output, in this case diphthong to a simple vowel as well as a stop to a continuant are relevant. Similarly, the output allows an epenthetic vowel violating DEP-IO (V). The ranking will be as follows in tableau (4.1): *CODA, *DIPH, *[b] >> IDENT-IO_{BACK}, DEP-IO (V), IDENT-IO_{DIPH/CONT}

(4.1) /^mbairəʊ/ → [eβiro] ‘biro’.

/ ^m bairəʊ/	*CODA	*DIPH	*[b]	IDENT-IO _{BACK}	DEP-IO (V)	IDENT-IO _{DIPH/CONT}
a. [bəi.rəʊ]		*!*	*			
b.  [e.βi.ro]					*	*
c. [e.bu.ro]			*!	*	*	
d. [e.βa.ɪr]	*!				*	*

From the tableau (4.1), candidate (b) is the optimal candidate; it satisfies all the markedness constraints while the rest of the candidates violate at least one high ranked constraint. It is the winning candidate although it violates the low ranked constraint DEP-IO(V) by allowing the epenthetic vowel and IDENT-IO_{DIPH/CONT} which forbids feature change. Candidate (a) is the most disharmonic. It not only violates the high ranked *DIPH but also allows the occurrence of /b/ which is not attested in the language. Candidate (c) does not fare well either, it allows for the occurrence of the voiced plosive /b/ which is not attested in the language besides violating the low ranked constraints by allowing the occurrence of a back vowel instead of front. Lastly, candidate (d) violates the high ranked undominated *CODA constraint besides the low ranked faithfulness constraint which prohibit vowel insertion DEP-IO (V). Hence, it is eliminated.

4.1.2. The Adaptation of /e/ in Ekegusii

Besides direct mapping, the mid-close front unrounded vowel /e/ substitutes a number of vocalic English sounds. These include: /ɪ/, /æ/, /ə/, /ɒ/ and the diphthong /eɪ/ as shown.

English Input	Ekegusii Output	English Gloss
/ˈbændɪdʒ/	[eβa ⁿ deci]	‘bandage’
/ˈkæptɪn/	[ekaβuteni]	‘captain’
/bæŋk/	[eβe ⁿ gi]	‘bank’
/ˈtræktə/	[ekerayita]	‘tractor’
/ˈkæmərə/	[ekamera]	‘camera’
/ˈæmbjələns/	[e.a ^m bjure ⁿ si]	‘ambulance’
/ˈbɒnɪt/	[eβeneti]	‘bonnet’
/breɪk/	[eβureki]	‘brake’

/steɪk/

[esiteki]

'stake'

Similarity of sounds between two languages brought by shared features play a role in language borrowing (McMahon, 1999). Therefore, the mid-close front vowel /e/ shares the [-back, +lax] features with both /æ/ and /ɪ/. The schwa which has a central feature is usually a weak sound and it is a lax vowel. Hence, it is simply realized as /e/. In the absence of a diphthong in Ekegusii, /eɪ/ undergoes reduction to become /e/. The schwa realization as simply /e/ is not unique to Ekegusii; this is a similar finding by Faezeh and Zafaranlu (2013) that with the absence of the schwa in Persian, it is simply realized as /e/. Of importance to note is that the substitution only allows vowels that are similar in terms of front and -back dimension so as to maintain harmony. OT has an explanation for this in that the markedness constraints *DIPH can be invoked. Further, from the data it can be inferred that the input 'break' /breɪk/ is adapted as [eβureki]. The input contains a cluster consonant 'br' which is not tolerated in the language. Therefore, *CO_{ONS} which disallows occurrence of complex clusters can be proposed to account for this adaptation. Moreover, the bilabial plosive /b/ which is not attested in the language is adapted as the labial fricative /β/. To account for this adaptation; undominated *[b] can be proposed. Moreover *CODA is undominated, hence it can be invoked as well. Additionally, on the faithfulness constraints, the input allows vowel insertion as a repair strategy. Thus, DEP-IO(V) can be proposed as well as IDENT-IO_{DIPH/CONT}. On the adaptation of the English input /'æmbjələns/ 'ambulance', it is adapted [e.a^mbjureⁿsi] in Ekegusii. The schwa /ə/ is not attested in the Ekegusii language. Thus, we can propose an undominated markedness constraint *[REDUCED-V] which prohibits the occurrence of a schwa. Similarly, laterals are not in the Ekegusii inventory. The undominated

*[LAT] constraint militates against their occurrence. Besides, *CODA constraint is undominated hence, it can be invoked. On the other hand, structural well-formedness constraints in OT are always counterbalanced by faithfulness constraints. Hence, it can be observed that the output allows insertion, so DEP-IO(V) is relevant as well as feature change, hence, the faithfulness constraint IDENT-IO_{LAT/NAS} can be proposed. The constraints will be ranked as follows in tableaux (4.2a and 4.2b).

*CODA, *DIPH, *CO_{ONS}, *[b] >> IDENT-IO_{DIPH/CONT}, DEP-IO(V)

*CODA, *[REDUCED-V], *[LAT] >> IDENT-IO_{LAT/NAS}, DEP-IO(V)

(4.2a) /breik/ → [eβureki] ‘brake’

/breik/	*CODA	*DIPH	*CO _{ONS}	*[b]	IDENT-IO _{DIPH/CONT}	DEP-IO(V)
a. [breik]	*!	*	*	*		
b.  [e.βu.re.ki]					**	**
c. [eβ.u.e.ki]	*!	*			**	**
d. [e.bre.ki]			*!	*	*	*

(4.2b) /'æmbjələns/ → [e.ɑ^mbju.re.ⁿsi] 'ambulance'

/'æmbjələns/	*CODA	*[REDUCED-V]	*[LAT]	IDENT-IO _{LAT/NAS}	DEP-IO(V)
a. ↗ [e.ɑ ^m bju.re. ⁿ si]				**	*
b. [e.ɑ. ^m bi.ɑ.le.nsi]			*!	*	**
c. [e.o. ^m bjə.re.nsi]		*!		**	*
d. [æ.mbjə.ləns]	*!	*	*		

In tableau (4.2a), candidate (b) is the most harmonic. The diphthong is replaced by the mid-high vowel /e/ so that it does not violate the high ranked markedness constraints *DIPH, as well as other undominated constraints like *CODA, *CO_{ONS} and *[b] which Ekegusii attaches importance to. On the other hand, (a) is the most disharmonic. It violates all the high ranked constraints *CODA, *DIPH, *CO_{ONS} and *[b] by allowing a coda, occurrence of a diphthong, a complex onset and a bilabial plosive that is not attested in the language. Candidate (c) does not fare well either, it allows diphthong thus violates the undominated *DIPH as well as the undominated *CODA besides the low ranked faithfulness constraints. Candidate (d) violates the high ranked *CO_{ONS} constraint which prohibits the occurrence of complex clusters as well as allowing the bilabial plosive /b/; a sound that is not attested in the Ekegusii language. In addition, it violates the low ranked DEP-IO(V) which disallows insertion. Hence, it is eliminated.

In tableau (4.2b), candidate (a) is the most harmonic although it violates the low ranked DEP-IO(V) which disallows vowel insertion and IDENT-IO_{LAT/NAS} which prohibit

feature change. Candidate (b) violates the high ranked *LAT which is undominated in the language, besides violating the low ranked IDENT-IO_{LAT} which disallows feature change and DEP-IO(V) which disallows insertion. As for candidate (c), it is eliminated on the account that it allows the occurrence of the reduced vowel which is not attested in the Ekegusii language; thus, it is eliminated. Similarly, candidate (d) is the most disharmonic. It violates all the undominated markedness constraints in Ekegusii; as a result, it is eliminated.

Still on the Ekegusii adaptation of sound /e/, the adaptation of /ɒ/ to /e/ is unusual. Whereas /ɒ/ is a low back vowel that is hardly rounded, in an unstressed position it is realized as a schwa. Therefore, this leads it to its mapping as /e/ which is a front unrounded mid-high vowel. This finding is not unique to Ekegusii. Zuzana (2014) in his study on loan integration in Vend Romani notes that some Hungarian nouns result to emergent patterns that deviate from the original xenoclitic inflectional forms and from the corresponding inflectional forms in Hungarian.

4.1.3. The Adaptation of /ɛ/ in Ekegusii

/ɛ/ is a mid-open front unrounded vowel in Ekegusii. The English vowels adapted to this sound are /æ/, /ə/ and the diphthong /ei/ as illustrated.

English Input	Ekegusii Output	English Gloss
/ˈbætri/	[ɛβetiri]	‘battery’
/ˈbeɪkəri/	[ɛβekeri]	‘bakery’

In terms of adaptation, sound /ɛ/ was not frequent. It substitutes /æ/ with which it shares [-back, +low] features. As for the schwa /ə/, the close approximation is /ɛ/ while the absence of diphthongs in the Ekegusii inventory facilitates the adaptation of the diphthong /eɪ/ as /ɛ/. As already accounted for in tableaux (4.2a and 4.2b), the markedness constraint *DIPH ensures no complex nucleus occurs in the Ekegusii language. So, in the adaptation of the English input ‘battery’ /ˈbætri/ as [ɛβetiri] in Ekegusii, a number of adaptations take place which can be accounted for by OT’s markedness constraints. First, there is the *CODA that is undominated. Secondly, Ekegusii does not allow complex consonant clusters. Consequently, a vowel is inserted. Therefore, *COONS which is an undominated markedness constraint can be proposed. Thirdly, the voiced bilabial plosive /b/ is not attested in the language, hence, the adaptation of /β/. Besides this markedness constraints, other faithfulness constraints like DEP-IO(V), MAX-IO_{SEG} and IDENT-IO_{CONT} which prohibit insertion, deletion and feature change respectively can be invoked to evaluate the output further. Following this adaptation, the constraints will be ranked as: *CODA, *COONS, *[b] >> MAX-IO_{SEG} >> IDENT-IO_{CONT}, DEP-IO(V)

(4.3) /'bætri/ → [ɛβɛtiri] 'battery'

/'bætri/	*CODA	*COONS	*[b]	MAX- IO _{SEG}	IDENT- IO _{CONT}	DEP- IO(V)
a. ☞ [ɛ.βɛ.ti.rɪ]					*	*
b. [ɛ.βɛ.rɪ]				*!	*	
c. [ɛ.βɛ.ti.rɪ]	*!				*	*
d. [ɛ.βɛ.tɪ.rɪ]		*!			*	
e. [ɛ.bɛ.ti.rɪ]			*!			*
f. [bæ.tɪ.rɪ]		*!	*			

Candidate (a) is the most harmonic, although it violates the low ranked faithfulness candidates that disallows insertion and feature change. It does not violate any of the high ranked markedness constraints. On the other hand, (b) does not violate the high ranked markedness constraints. However, it is eliminated on the account that it violates MAX-IO_{SEG}. Though not a markedness constraint, Ekegusii ranks it higher than other faithfulness constraints but lower than the markedness constraints. Candidate (c), (d) and (e) are all isoharmonic. Each of them violates at least one of the high ranked markedness constraints; *CODA, *COONS and *[b] respectively besides the low ranked faithfulness constraints. Lastly, candidate (f) is the most disharmonic. Although it does not violate any of the low ranked faithfulness constraints, it violates two of the high

ranked markedness constraints *CO_{ONS} and *[b]; consequently, it suffers fatal elimination.

4.1.4. The Adaptation of /a/ in Ekegusii

Different English vowels were easily substituted with the open unrounded central vowel /a/. They are: /æ/, /ɜ:/, /ə/, /ʌ/ and the diphthong /ei/.

English Input	Ekegusii Output	English Gloss
/trænsfɜ:/	[eturansiβa]	‘transfer’
/tæŋk/	[eta ^ŋ gi]	‘tank’
/θɜ:məs/	[etamosi]	‘thermos’
/ju:nɪ'vɜ:sɪtɪ/	[ejuniβasiti]	‘university’
/'eɪkə/	[ɛ.ɛ.ka]	‘acre’
/ə'kaʊnt/	[e.a.ka.o. ⁿ ti]	‘account’
/'kʌpərd/	[ekaβati]	‘cupboard’
/'kʌmpəni/	[eka ^m bani]	‘company’
/'eɪprən/	[e.a.βuroni]	‘apron’

As shown from the data, /a/ is adapted in place of /æ/, /ɜ:/ and /ə/. These vowels are part of the schwa, share [-back, +low, -round] features. In the case of the schwa which is a central vowel, there seems to be fronting. Besides, /a/ is adapted in place of the mid-open back unrounded vowel /ʌ/. The shared features which perhaps motivates the substitution are [+low] and [-round]. As for the diphthong, there is reduction. In addition, /a/ is one of the extreme vowels in the canonical vowel space besides /ɪ/ and /u/ (Lieberman, 1995; Flemming, 2004). It is preferred and favoured cross linguistically and because of its unmarkedness; it is adapted in Ekegusii in place of /æ/, /ɜ:/, /ə/, /ʌ/ and the diphthong /ei/. We can use OT’s constraints to account for the adaptation of ‘university’ /ju:nɪ'vɜ:sɪtɪ/ as [ejuniβasiti]. First is *CODA that is consistently

undominated. Then, the adaptation of the labial dental fricative /v/ as /β/; here we can propose the undominated markedness constraint; *[CONT, LAB-DENT]. Also, the input's long vowels are adapted as short vowels violating the IDENT-IO_{LONG}. Similarly, the input allows epenthesis hence, DEP-IO(V) is a relevant faithfulness constraint which can be invoked. The constraints in tableau (4.4a) will be ranked as follows:

*CODA, *[CONT, LAB-DENT] >> IDENT-IO_{LONG}, DEP-IO(V)

(4.4a) /ju:nɪ'vɜ:sɪtɪ/ → [ejuniβasiti] 'university'

/ju:nɪ'vɜ:sɪtɪ/	*CODA	*[CONT, LAB-DENT]	IDENT-IO _{LONG}	DEP-IO(V)
a. [e.ju.ni.βa.si.ti]			**	*
b. [e.ju.ni.βa.si.ɪt]	*!		**	*
c. [ju:nɪ.vɜ:sɪ.ti]		*!		
d. [e.ju.ni.vɜ:sɪ.ɪt]	*!	*	*	*

In tableaux (4.4a) candidates (d) is the most disharmonic. It not only violates the undominated *CODA and *[CONT, LAB-DENT] constraints but also the low ranked faithfulness constraints. Hence, it is eliminated. As for candidates (b) and (c) both are isoharmonic. They each violate one of the high ranked markedness constraints which are *CODA and *[CONT, LAB-DENT] respectively besides violating the low ranked faithfulness constraints. So, both are eliminated. Candidate (a) is the winner although it violates the DEP-IO(V) which disallows insertion.

Similarly, in tableau (4.4b) ‘cupboard’ /kʌpəd/ is adapted as [ekaβati]. The constraints which can account for this adaptation include: *CODA which is undominated; the schwa which is not attested in the language can be accounted for with the markedness constraint *[REDUCED-V]. Equally, the bilabial voiceless plosive is not attested in the language; so, we propose the undominated markedness constraint; *[p]. Also, there is obstruent devoicing when the voiced alveolar /d/ is replaced with /t/. Thus, *OBSVOI can be invoked. Markedness constraints interact with faithfulness candidates to determine the optimal candidate. Looking at the output we can note that it allows insertion so DEP-IO(V) is relevant, as well as MAX-IO_{SEG} which forbids deletion and IDENT-IO_{CONT} which disallows feature change. The constraints will be ranked as follows in tableau (4.4b);

*CODA, *[REDUCED-V], *[p] >> *OBSVOI >> MAX-IO_{SEG} >> DEP-IO(V),
IDENT-IO_{CONT}

(4.4b) /kʌpəd/ → [ekaβati] ‘cupboard’

/kʌpəd/	*CO DA	*[REDUCED -V]	*[p]	*OBSVOI	MAX- IO _{SEG}	DEP- IO(V)	IDENT- IO _{CONT}
a. ↗ [e.ka.βa.ti]						*	*
b. [kʌ.pəd]	*!	*	*	*			
c. [e.ka.βə.ti]		*!				*	*
d. [e.ka. βa]					*!		*

Candidate (a) is the most harmonic. It does not violate any of the high ranked markedness constraints in Ekegusii instead, it violates the low ranked DEP-IO(V) and IDENT-IO_{CONT} which disallow epenthesis and feature change respectively. On the other hand, candidate (b) is the most disharmonic. Though it does not violate any of the faithfulness constraints, it violates all the high ranked markedness constraints, hence, it does not survive. Candidate (d) is very similar to the winner in terms of harmony. However, it violates the universal faithfulness constraint MAX-IO_{SEG} which Ekegusii ranks higher than DEP-IO(V) and IDENT-IO_{CONT} which prohibits epenthesis and feature change. As for candidate (c), it does not fare well either. It allows the occurrence of the reduced vowel, a sound that is not attested in the language. Thus, it is eliminated.

4.1.5. The Adaptation of /o/ in Ekegusii

The mid-close back rounded vowel was very frequent in occurrence. It was adapted in place for /ɒ/, /ə/, /ʊ/, /ɔ:/ and the diphthong /əʊ/.

English Input	Ekegusii Output	English Gloss
/bɒm/	[eβomu]	‘bomb’
/'kɒrɪdɔ:/	[ekorido]	‘corridor’
/kən'dʌktə/	[eko ⁿ dayita]	‘conductor’
/'kʊʃən/	[ekosoni]	‘cushion’
/'bɔʊlt/	[eβoriti]	‘bolt’
/pəʊst/	[eβositi]	‘post’
/'lɔ:jə/	[eroya]	‘lawyer’
/stɔ:/	[esito]	‘store’

Both the open back round vowel /ɒ/, the mid back round long vowel /ɔ:/ and the back mid close round vowel /ʊ/ are close in terms of horizontal tongue position and lip rounding; thus, the substitution is not a surprise. Similarly, the schwa seems to be

closing towards /o/ sound. Absence of diphthongs in Ekegusii language justifies the reduction of /əʊ/ to a simply /o/ with which it shares features [+back, +round]. OT's universal markedness constraint *CODA and the language's well-formedness constraints *DIPH can account for the adaptation of 'post' /pəʊst/ as [e.βo.si.ti] in Ekegusii. In addition, the input has a cluster consonant that is not tolerated in Ekegusii. Hence, the markedness constraint *CO_{ONS} which prohibits a cluster can be invoked. Similarly, the bilabial plosive is not attested in the language. The undominated markedness constraint *[p] is proposed. All the constraints proposed are markedness. Ordinarily, universal markedness constraints are counterbalanced by faithfulness constraints. In this case, the output violates DEP-IO(V) and IDENT-IO_{DIPH/CONT} by allowing insertion and feature change respectively. The constraints are ranked as follows:

*CODA, *DIPH, *CO_{ONS}, *[p] >> IDENT-IO_{DIPH/CONT}, DEP-IO(V)

(4.5) /pəʊst/ → [e.βo.si.ti] 'post'

/pəʊst/	*CODA	*DIPH	*CO _{ONS}	*[p]	IDENT-IO _{DIPH/CONT}	DEP-IO(V)
a. [pəʊst]	*!	*	*	*		
b.  [e.βo.si.ti]					**	**
c. [e.po.si.ti]				*!	*	**
d. [e.βəʊ.sti]		*!	*			

Tableau (4.5) indicates that candidate (a) is the most disharmonic. It violates all the high ranked *CODA, *DIPH, *CO_{ONS} and *[p] markedness constraints. Hence, it is eliminated. (b) is the most harmonic despite the fact that it violates DEP-IO(V) by allowing insertion of vowels and feature change in the output. As for candidate (c), it allows the occurrence of the voiceless bilabial plosive which is not attested in the Ekegusii language besides violating the low ranked DEP-IO(V) and IDENT-IO_{DIPH/CONT} which militates against insertion and feature change respectively. Candidate (d) is equally less harmonic. It violates two of the high ranked markedness constraints that is, *DIPH which disallows diphthongs in Ekegusii and *CO_{ONS} which forbids a complex cluster. Thus, it does not survive.

This finding is similar to that of Faezeh and Zafaranlu (2013). They found that in Persian adaptation of German loans, German diphthongs are changed to simple vowels. They also note that the back lax vowel [O] in German is changed to the tense vowel /o/ in Persian.

4.1.6. The Adaptation of /u/ in Ekegusii

This is the back close round vowel /u/.

English Input	Ekegusii Output	English Gloss
/ru:lə/	[erura]	‘ruler’
/stu:l/	[esuturu]	‘stool’
/ju:nɪ'vɜ:sɪtɪ/	[ejuniβasiti]	‘university’
/'trʌmpɪt/	[etaru ^m beta]	‘trumpet’
/'kʊkə/	[ekuka]	‘cooker’

In all the instances where we had the long back close round vowel /u:/, it was mapped to the /u/ in Ekegusii. Both share [+round, +back, +high] features. Equally, the low back unrounded vowel /ʌ/ and /ɔ/ were substituted with the /u/ with which they share the [+back] feature. If we illustrate using ‘stool’ /stu:l/ which is adapted as [esuturu]: First, *CODA is constantly undominated. Secondly, the output allows epenthesis to break the cluster comprising a consonant and an obstruent. The markedness undominated *CO_{ONS} which prohibits clusters is a relevant constraint. Another undominated markedness constraint which can be proposed is *[LAT] since laterals are not in the Ekegusii inventory which explains why the rhotic /r/ is adapted. The faithfulness constraints DEP-IO(V) and IDENT-IO_{LONG/LAT} can similarly be used to explain the adaptation. The output allows insertion and feature change. The constraints will be ranked as follows:

*CODA, *CO_{ONSET}, *[LAT] >> DEP-IO(V), IDENT-IO_{LONG/LAT}

(4.6) /stu:l/ → [esuturu] ‘stool’

/stu:l/	*CODA	*CO _{ONSET}	*[LAT]	DEP-IO(V)	IDENT-IO _{LONG/LAT}
a. [stu:l]	*!	*	*		
b.  [e.su.tu.ru]				**	**
c. [e.stu.ru]		*!		*	**
d. [e.su.tu.lu]			*!	**	*

Tableau (4.6) indicates that candidate (a) is the most disharmonic. It violates all the high ranked undominated markedness constraints which include; *CODA, *CO_{ONS} and

*[LAT]; thus, it is eliminated. (b) is the most harmonic despite the fact that it violates DEP-IO(V) by allowing insertion of vowels and also feature change in that the long vowel has been realized as a short vowel and the lateral adapted as a trill in the output. As for candidate (c) and (d), they each violate one of the high ranked markedness constraints *CO_{ONS} and *[LAT] respectively which the language ranks highly as well as the low ranked faithfulness constraints. Therefore, they are eliminated.

Generally on vowel adaptation, it can be observed that English vowels tend to be substituted with those in Ekegusii which they have shared features in terms of horizontal and vertical tongue position, tenseness as well as shape of the lips. Also, the schwa which is not in the Ekegusii inventory is very mobile and unpredictable when it is adapted. Otherwise, apart from the unusual pattern where English back vowels /ɒ/ and /ʌ/ are adapted to Ekegusii /e/ and /a/ respectively; the adaptation is relatively predictable; since the back and front English vowels are adapted to the back and front Ekegusii vowels respectively. Consequently, only vowels that are similar in terms of height, front and back dimensions are allowed to substitute one another so as to maintain vowel harmony.

These findings are consistent with those of Sayahi (2005). He found that when Spanish loans are adapted to Moroccan Arabic which has a simple vowel inventory of three vowels, vowels /e/ and /o/ become /i/ and /u/ respectively in Moroccan Arabic. This he explains results from the process of pharyngealization which dictates that if a consonant is pharyngealized, then the flanking vowels have to be raised (/e/ to /i/ and /o/ to /u/).

Further, these findings on Ekegusii vowel adaptation differ from Mogaka's (2009) findings. She found that vowel /i/ changes /e/, /u/ is adapted /i/, /u/ changes to /o/ while /ɔ/ changes to /u/ and in some instances still /ɔ/ becomes /i/. This substitution is not predictable. This could be explained from the fact that Kiswahili which is a Bantu language just like Ekegusii has five vocalic phonemes unlike English which has twenty-four vowels.

4.2. The Adaptation of Consonants in Ekegusii

Consonant sounds are described according to the place of articulation (the different places on the roof of the mouth, the movements of the lips and different parts of the tongue), they are also characterized by manner of articulation and phonation (Ladefoged & Johnson, 2011). In adaptation of consonant sounds in borrowing, Zafaranlu and Hashemi (2011) note that the recipient language will phonemically replace non-existing donor consonants with similar existing ones in terms of place and manner of articulation as well as phonation. However, others are of the view that this adaptation is based on the perspective of auditory similarity rather than proximity in feature geometry or shared natural classes (Kenstowicz, 2005). We investigated what determines the adaptation of English consonants in Ekegusii borrowing. On consonant adaptation, we grouped the English consonants according to the substituting consonant(s) in Ekegusii.

4.2.1 Adaptation of English Consonants /b/, /p/, /v/, /f/ to Ekegusii's /β/

English Input	Ekegusii Output	English Gloss
/bæŋk/	[eβe ⁿ gi]	'bank'
/'beɪsn/	[eβeseni]	'basin'
/'helɪkɒptə/	[erikoβita]	'helicopter'
/'plæstɪk/	[eβurasitiki]	'plastic'
/'gʌvənə/	[eγaβana]	'governor'
/'ju:nɪ'vɜ:sɪtɪ/	[ejuniβasiti]	'university'
/'refə'rendəm/	[eriβera ⁿ damu]	'referendum'
/'səʊfə/	[esoβa]	'sofa'

/β/ is a voiced bilabial fricative in the Ekegusii language, while /b/ and /p/ are voiced bilabial plosive and voiceless bilabial plosive respectively. These two bilabials are only attested in the Ekegusii language in the pre-nasalized forms. With the absence of these two bilabials in Ekegusii inventory, there is a phonemic substitution of what is existing /β/, whether they are in the initial or medial positions. All the three sounds share [+labial] [+anterior] and [-sonorant] features thus, the substitution. On the other hand, /β/ is adapted in place of the voiced labial-dental fricative /v/ and the voiceless labial-dental fricative /f/ whether in the initial or medial position. In this case, both sounds are fricatives. Katamba (2003) observes that, this is not accidental, in fact in many languages, fricatives, plosives and affricates form a natural class called obstruents. Katamba further observes that these sounds share the phonetic characteristics of having significant obstruction in the oral tract and being typically voiceless. Moreover, they tend to display similar phonological behaviour. Though voiceless obstruents are cross linguistically preferred, in the absence of the other obstruents which are close in terms of place and manner of articulation, then the bilabial fricative /β/ becomes an appropriate substitution. Save for one instance whereby the English loanword ['bɪskɪt] was adapted as [eyesuyuti], thereby /b/ changing to /ɣ/ which is a voiced velar fricative

all the other adaptations were predictable. Though in this case, there are shared features of [+labial, +voice].

Generally, it can be noted that in the adaptation of the English bilabials and fricatives, the closest sound is the bilabial fricative /β/ which is also an obstruent. This adaptation can be accounted for using OT. First the bilabial plosives are only attested in Ekegusii language as pre-nasalized segments. Hence, the markedness constraints *[p] and *[b] are relevant. Then, labial dentals can be accounted for using *[CONT, LAB-DENT] markedness constraint. If we illustrate using the adaptation of ‘bank’ /bæŋk/ as [e.βe.^hgi] in the Ekegusii, a number of constraints can be invoked. First is the undominated *CODA. Secondly, we invoke *[b] that ensures that voiced bilabial stops do not occur in Ekegusii. Thirdly, on markedness constraints is the post nasal voicing *NÇ. All these are markedness constraints which ought to interact with faithfulness constraints so as to evaluate candidates. In this regard, Ekegusii outputs are observed to violate some faithfulness constraints since there is disparity between the input-output mappings. Therefore, DEP-IO(V) which inhibits insertion is relevant. Secondly, IDENT-IO_{CONT/VOI} which disallows feature change is appropriate. The constraints will be ranked as follows: *CODA, *[b] >> *NÇ >> DEP-IO(V), IDENT-IO_{CONT/VOI}

(4.7a) /bæŋk/ → [e.βe.ŋgi] ‘bank’

/bæŋk/	*CODA	*[b]	*NC̣	DEP-IO-V	IDENT-IO _{CONT/VOI}
a. [bæŋk]	*!	*	*		
b. [e.be.ŋgi]		*!		*	*
c. [e.βe.ŋgi]				*	**
d. e.βe.ŋki]			*!	*	*

Candidate (a) is the most disharmonic. It violates all the undominated markedness constraints *CODA, *[b] and *NC̣ which are very important to the Ekegusii language, hence it does not survive. However, the language is less concerned with DEP-IO(V) which is the insertion of the vowels and IDENT-IO_{CONT/VOI} which is feature change; since these are violated by the optimal candidate (c). Candidate (b) is less harmonic compared to the winner. It allows for the occurrence of the voiced bilabial plosive /b/, violating the high ranked undominated markedness constraint *[b] besides the low ranked faithfulness constraint DEP-IO(V) which is anti-insertion. Therefore, it is suffers fatal elimination. Likewise, candidate (d) is less harmonic. It violates not only the low ranked DEP-IO(V) and IDENT-IO_{CONT/VOI} but also the high ranked markedness constraint post nasal voicing *NC̣; which is typical of Bantu languages. Hence, it is eliminated.

Similarly, another input in the same category of adaptation is ‘sofa’ /səʊfə/, adapted as [e.so.βa]. Two undominated markedness constraints can be proposed: *DIPH which is anti-diphthong and *[CONT, LAB-DENT] which disallows the occurrence of the labial

dental fricative. Also relevant is the markedness constraint [REDUCED-V] which disallows the schwa in Ekegusii. The faithfulness constraints which can be proposed to evaluate the outputs further are MAX-IO_{SEG} which prohibits deletion and IDENT-IO_{DIPH} which disallows feature change in this case a diphthong to a simple vowel. In tableau (4.7b), the constraints will be ranked as: *DIPH, *[CONT, LAB-DENT], [REDUCED-V] >> MAX-IO_{SEG} >> IDENT-IO_{DIPH}

(4.7b) /'səʊfə/ → [e.so.βa] 'sofa'

/'səʊfə/	*DIPH	*[CONT, LAB-DENT]	[REDUCED-V]	MAX-IO _{SEG}	IDENT-IO _{DIPH}
a. [səʊ.fə]	*!	*	*		
b. [e.səʊ.βa]	*!				
c. [so.fə]		*!			*
d. [e.so]				*!	*
e. ↵ [e.so.βa]					*

From tableau (4.7b), candidate (a) is most disharmonic. It violates all the high ranked markedness constraints *DIPH and *[CONT, LAB-DENT] and [REDUCED-V], thus it is eliminated. Both candidates (b) and (c) are isoharmonic. They each violate one of the high ranked markedness constraint in Ekegusii; *DIPH and *[CONT, LAB-DENT]. As a result, both are eliminated. As for candidate (d), it violates MAX-IO_{SEG}; though a faithfulness constraint, Ekegusii ranks it higher than other faithfulness candidate which prohibit both feature change and insertion. Candidate (e) is the winner. It wins optimally by violating the low ranked IDENT-IO_{DIPH} which militates against feature change.

These findings established in Ekegusii on the adaption of /b/, /p/, /v/ /f/ are similar to some extent to what Sarkar (2012) found in loan adaptation of Bangla; a language spoken in India. He found that the bilabial fricative /b/ substitutes the voiced labiodental fricative /v/ in the coda position. Similarly, Silverman (1992) found that in Cantonese, the English /b/ is replaced by /p/.

4.2.2 Adaptation of English Consonant /g/ to Ekegusii's /ɣ/, /k/, /^hg /

English Input	Ekegusii Output	English Gloss
/geɪt/	[eyeita]	'gate'
/gaʊn/	[eɣaoni]	'gown'
/'bæg/	[eβayi]	'bag'
/glɑ:s/	[ekerasi]	'glass'
/gə'zet/	[e ^h gaseti]	'gazette'
/bɒks/	[eβoyisi]	'box'
/'pækɪt/	[eβayeti]	'packet'

/ɣ/ is a voiced velar fricative found in Ekegusii. In terms of adaptation, it dominantly substituted the English /g/ which only exists as a pre-nasalized segment in Ekegusii occurring in syllable initial position. /ɣ/ was also adapted in few instances where we had /k/ although the voiceless velar stop is found in the Ekegusii inventory. Another adaptation was that of /g/ to /^hg/ in Ekegusii which is the attested pre-nasalized form. These two share the features [+dorsal], [+son], [+back] and [+high]. *[OBSVOI] a constraint which prohibits the voicing of pure obstruents can apply here because [^hg] is not pure stop, it is tolerated having acquired voicing from nasalization. Moreover, the four sounds /g/, /ɣ/, /k/, and /^hg/ are all obstruents. In this case we can formulate a *[g] constraint that Ekegusii imposes on English donor words whose input comprises the

voiced velar obstruent like ‘gown’ /gaʊn/ adapted as [e.ɣa.o.ni]. In addition, Ekegusii does not tolerate diphthongs. The constraint *[DIPH] is relevant as well as the *[CODA] constraint that is consistently undominated. Other constraints which can be invoked to further evaluate the candidates are DEP-IO(V) which prohibits insertion, MAX-IO_{SEG} which disallows deletion and IDENT-IO_{DIPH} which disallows feature change. The constraints can be ranked as:

*CODA, *[DIPH], *[g] >> MAX-IO_{SEG} >> DEP-IO(V), IDENT-IO_{DIPH}

(4.8) /gaʊn/ → [e.ɣa.o.ni] ‘gown’

/gaʊn/	*CODA	*[DIPH]	*[g]	MAX-IO _{SEG}	DEP-IO(V)	IDENT-IO _{DIPH}
a. [gaʊn]	*!	*	*			
b. [e.ga.on]	*!		*		*	*
c.  [e.ɣa.o.ni]					**	*
d. [e.ɣa.o]				*!	*	*

In OT, borrowed segments are governed by the same set of universal constraints; however, the constraints are ranked according to the phonology of the recipient language. As shown from the data, Ekegusii ranks the markedness constraints *CODA, *[DIPH] and *[g] which strictly dominate MAX-IO_{SEG} constraint which disallows deletion. This constraint too dominates the faithfulness constraint because the input does not correlate one-on-one with the output since there is insertion and feature change. Consequently, in tableau (4.8) candidate (a), (b) and (d) are eliminated.

Candidate (a) violates all the markedness constraints. (b) violates the undominated *CODA constraint that prohibits the occurrence of consonants at the coda position as well as *[g] which prohibits the velar stop. As for (d), it allows for the deletion, violating MAX-IO_{SEG} which Ekegusii ranks higher and attaches importance to, hence, it is thrown out. Candidate (c) is the optimum candidate although it violates the faithfulness constraints by allowing insertion of vowels and feature change. Thus, it survives though it violates the faithfulness constraints.

This finding on velar adaptation is very similar to Thai adaptation of English loans. Runruang (2007) found that in Thai loans, the English /g/ is adapted to /k/. This again can be attributed to the constraint *[OBSVOI] that punishes obstruent voicing.

4.2.3 Adaptation of English Consonants /d/, /θ/ to Ekegusii's /t/

English Input	Ekegusii Output	English Gloss
/hed'mɑ:stə/	[etumasita]	'headmaster'
/kʌpəd/	[ekaβati]	'cupboard'
/dʌstə/	[etasita]	'duster'
/desk/	[etesiki]	'desk'
/dɪstrɪkt/	[etisiriɣiti]	'district'
/θɜ:məs/	[etamosi]	'thermos'
/bɑ:θru:m/	[eβaturumu]	'bathroom'

In the absence of the voiced alveolar plosive /d/ and the voiceless dental fricative /θ/, the voiceless alveolar plosive /t/ is adapted. This confirms Paradis (1996) argument that when a segment is not preserved, its closest phoneme in the borrowing language is adapted. Besides, /d/, /θ/ and /t/ are all obstruents. Cross linguistically, the unmarked voiceless obstruents are preferred while the voiced are marked and avoided. Thus, the

mapping to /t/ instead of /d/ is the most natural, besides both are alveolar plosives in terms of place and manner of articulation. Further, voiceless plosives are the unmarked segments relative to fricatives hence the adaptation of /t/ in place of /θ/. They also share the features [+anterior], [+coronal], [-syllabic] and [-sonorant].

OT accounts for this adaptation in Ekegusii. For instance, if we illustrate using ‘bathroom’ /ba:θru:m/ adapted as [eβaturumu] in Ekegusii first; it imposes a constraint *[b] which prohibits the voiced bilabial obstruents which is marked cross linguistically. Secondly, from the data it is evident Ekegusii does not allow cluster consonants although in other instances it allows the occurrence of a consonant and a glide. Therefore, we can invoke the constraint *CLONS which is undominated besides *CODA. In addition, the voiceless dental fricative /θ/ is not attested in Ekegusii language. Hence, the markedness constraint *[CONT, DENT] can be proposed. On faithfulness constraints those which are relevant in this case are DEP-IO(V) which prohibits insertion and IDENT-IO_{CONT/LONG} which disallows feature change in this case a [+cont] and the reduction of long vowels to simple vowels. The constraints can be ranked as follows:

*CODA, *CLONS, *[b], *[CONT, DENT] >> DEP-IO_{SEG}, IDENT-IO_{CONT/LONG}

(4.9) /ba:θru:m/ → [eβaturumu] ‘bathroom’

[ba:θru:m]	*CODA	*CLONS	*[b]	*[CONT, DENT]	DEP-IO(V)	IDENT-IO _{CONT/LONG}
a.  [e.βa.tu.ru.mu]					**	***
b. [ba:θrum]	*!	*	*	*		
c. e.ba.tru.mu		*!	*		*	***
d. e.βa:θu.ru.mu				*!	**	**

As shown in tableau (4.9), though candidate (a) incurs violations, they are for the low ranked faithfulness constraints; DEP-IO(V) which disallows insertion and IDENT-IO_{CONT/LONG} which prohibit feature change. So, it is said to be optimal. However, (b) is the most disharmonic. It violates *CODA, *CLONS, *[b] and *[CONT, DENT] constraints which are highly ranked hence undominated in Ekegusii language. So, it is eliminated. Candidate (c) on the other hand does not fare well either, it violates the high ranked *CLONS besides the low ranked faithfulness constraints. As for candidate (d), it violates the undominated *[CONT, DENT] constraint besides the low ranked faithfulness candidates, hence it is eliminated. The language markedness constraints dominate the faithfulness constraints which ensure correspondence between the underlying form and the surface forms. This finding on the adaptation of /θ/ and /d/ to /t/ in Ekegusii is slightly similar to the finding of Rungruang (2007) in the adaptation of English loans to Thai language. He found that Thai replaces /ð/ with /d/.

Still on the adaptation of voiceless obstruents, there are instances whereby those which are preceded by nasal undergo voicing; so that, they become tolerated in the Ekegusii language. Here are examples:

English Input	Ekegusii Output	English Gloss
/kæmp/	[eka ^m bi]	‘camp’
/'dʒʌmpə/	[eca ^m ba]	‘jumper’
/tæŋk/	[eta ^ŋ gi]	‘tank’
/'blæŋkɪt/	[oβora ^ŋ geti]	‘blanket’

Much as Ekegusii language disallows occurrence of cluster consonants, except for a consonant followed by a glide, it is evident that it allows prenasalized stops which are realized as single homorganic sounds. Similarly, this is attested in other Bantu languages as observed by Nandelenga (2013) in Lubukusu. From the data presented, the adaptation of a sequence of a nasal followed by a voiceless plosive in this case /p/ and /k/ which is marked cross linguistically undergoes post nasal voicing so as to be realised as prenasalized stops. An input like ‘camp’ /kæmp/ is adapted as [eka^mbi]. OT accounts for this adaptation in that the markedness constraint *NC̥ which disallows a sequence of a nasal and voiceless plosive is invoked. This constraint dominates faithfulness constraints because the voiceless plosive acquires the [+voice] feature of the nasal hence bringing a disparity between the input and the output. *CODA which is undominated is invoked to prohibit any *NC̥ cluster from occurring as syllable boundary. Other relevant faithfulness constraints which can be invoked are IDENT-IO_{VOICE}. Further, the voiceless stops acquire the nasal feature so that they are realized as prenasalized stops. Thus, the constraint IDENT-IO_{NASAL} is relevant. The constraints will be ranked as follows:

*CODA >> *NÇ >> IDENT-IO_{VOI/NAS}, DEP-IO(V)

(4.10a) /kæmp/ → [eka^mbi] ‘camp’

/kæmp/	*CODA	*NÇ	IDENT-IO _{VOI/NAS}	DEP-IO(V)
a. [kæmp]	*!	*		
b. [e.ka.mpi]		*!		*
c.  [e.ka. ^m bi]			**	*
d. [ek.a. ^m bi]	*!		**	*

From tableau (4.10a), the optimal candidate (c) allows the voiceless obstruent to undergo voicing and acquire the nasal feature thus, it is adapted as a prenasalized stop that is the attested form in the Ekegusii language. Candidate (b) and (d) are eliminated because of strict dominance of the high ranked markedness constraints *CODA which candidate (d) violates and *NÇ which is violated by candidate (c). As for candidate (a), it is the most disharmonic. It violates the high ranked *CODA constraint and it disallows post nasal voicing which is preferred in the language. Otherwise, post-nasal voicing is very prevalent in the languages of the world (Pater, 1999; 2004; Archangeli, Moll, & Ohno, 1998).

Another input which can be accounted for is /'blæŋkɪt/ adapted as [oβora^ŋgeti] ‘blanket’. Obviously, there is no direct mapping between the input to the output. In this regard, a number of markedness and faithfulness can be posited. First, it is clear Ekegusii does

not tolerate consonant clusters which are in the input. So, we can posit the constraint *CL_{ONS} another of the markedness constraints subsumed under *COMPLEX_{ONSET} and it disallows a cluster onset in this case: onset consonant and a liquid. This constraint is undominated just like *CODA constraint. Besides, laterals are not attested in Ekegusii language. Consequently, *LAT is proposed to prohibit their occurrence. In addition, the output is observed to violate the faithfulness constraints by allowing feature change and insertion. Therefore, IDENT_{VOI/NAS/LAT} and DEP-IO(V) are relevant. The constraints will be ranked as follows:

*CODA, *CL_{ONS}, *LAT >> *NÇ >> IDENT-IO_{VOI/NAS/LAT}, DEP-IO(V)

(4.10b) /'blæŋkɪt/ → [oβora^ŋge.ti] 'blanket'

/'blæŋkɪt/	*CODA	*CL _{ONS}	*LAT	*NÇ	IDENT- IO _{VOI/NAS/LAT}	DEP-IO(V)
a. [blæ.ŋkɪt]	*!	*	*	*		
b. [blæ.ŋge.tɪ]		*!	*		**	*
c. [o.βo.ra.ŋke.ti]				*!	*	**
d.  [o.βo.ra. ^ŋ ge.ti]					***	**
e. [o.βo.ra. ^ŋ ke.it]	*!				*	**

From tableau (4.10b), the optimal candidate (d) allows the voiceless obstruent to undergo voicing and acquire the nasal features; thus, it is adapted as a prenasalized stop that is attested in the Ekegusii language. It also inserts vowel so as to break consonant

clusters which are not tolerated in the Ekegusii language. Candidate (a) is the most disharmonic. It violates the high ranked *CODA, *CLONS, *LAT and *NÇ constraints which prohibits coda, consonant clusters, occurrence of laterals and post nasal devoicing respectively hence, it is eliminated. As for candidate (b), it is eliminated because of strict dominance of the higher ranked markedness constraint *CLONS and *LAT which it violates besides the faithfulness candidates. Candidate (c) and (e) violate the high ranked markedness constraints *NÇ and *CODA respectively; consequently, they are eliminated.

4.2.4 Adaptation of English Consonants /z/, /ʃ/ /ʒ/ to Ekegusii's /s/

English Input	Ekegusii Output	English Gloss
/ˈbæptɪzəm/	[eβatiso]	‘baptism’
/bæpˈtaɪz/	[βatisa]	‘baptize’
/gəˈzɛt/	[e ^h gaseti]	‘gazette’
/ˈʃɪlɪŋ/	[esiri ^h gi]	‘shilling’
/ˈkʊʃən/	[ekosoni]	‘cushion’
/steɪʃn/	[esiteseni]	‘station’
/ʃɜ:t/	[esati]	‘shirt’
/ˈtreʒərə/	[eturesara]	‘treasurer’

The voiceless alveolar fricative /s/ is the closest phoneme in Ekegusii to the voiced alveolar fricative /z/. Likewise, with the absence of the voiced and the voiceless post alveolar fricatives /ʒ/ and /ʃ/ respectively, the closer adaptation is /s/. Paradis and Prunet (1991 & 1994) note that coronals especially alveolars are the unmarked and if they are voiceless, they are preferred cross linguistically. Besides, all the three sounds are stridents. To account for the adaptation of /s/ in place of other coronals, we invoke OT's

constraints. First, there is the *CODA constraint that is undominated in the language. Secondly, in the absence of the three sounds /z/, /ʃ/ and /ʒ/, the proposed constraints are *OBSVOI and *[j]. Like the adaptation of ‘treasurer’ /'treʒərə/ as [eturesara], *OBSVOI is adopted as the markedness constraint as well as the undominated *CO_{ONS} because of the presence of a cluster. Also, there is a schwa that is present in the input but not attested in the Ekegusii language; undominated *[REDUCED-V] is proposed. In addition, it can be noted that there is no correspondence between the input and the output. Specifically, there is vowel insertion as well as feature change in terms of voice. Thus, DEP-IO(V) and IDENT-IO_{VOI} are relevant. So, in tableau (4.11a), the constraints will be ranked as follows:

*CODA, *CO_{ONS}, *[REDUCED-V] >> *OBSVOI >> IDENT-IO_{VOICE}, DEP-IO(V).

(4.11a) /'treʒərə/ \longrightarrow [e.tu.re.sa.ra] ‘treasurer’

/'treʒərə/	*CODA	*CO _{ONS}	*[REDUCED-V]	*OBSVOI	IDENT-IO _{VOI}	DEP-IO(V)
a. [tre.sa.ra]		*!			*	
b. [e.tre.sar.a]	*!	*			*	
c.  [e.tu.re.sa.ra]					*	*
d. [tre.ʒə.rə]		*!	*	*		

As shown in tableau (4.11a), the constraints are ranked depending on the Ekegusii phonology which is the recipient language. Ekegusii ranks the markedness language constraints of *CODA, *CO_{ONS} and *[REDUCED-V] higher than *OBSVOI followed by IDENT-IO_{VOI} and DEP-IO(V) which are not crucially ranked. Consequently,

candidate (c) is the most harmonic because it does not violate the constraints that Ekegusii language ranks high. Candidate (a) violates the high ranked markedness constraint *CO_{ONS}, as a result it is eliminated. As for candidate (d), it is the most disharmonic. It violates three of the four undominated markedness constraints; *CO_{ONS}, *[REDUCED-V] and *OBSVOI which forbid the occurrence of complex onset, the reduced vowel and obstruent voicing respectively, thus, it is thrown out. Finally, candidate (b) does not fare well either. It violates two of the undominated markedness constraints in Ekegusii, that is, *CODA and *CO_{ONS} as well as the faithfulness constraint IDENT-IO_{VOI}; hence, it does not survive.

Another English input is /bæptɪzəm/ adapted as [e.βa.ti.so]. To account for the adaptation of /z/ as /s/, we propose the universal markedness constraint *OBSVOI which prohibits obstruent voicing. Equally, it can be observed that consonant clusters are broken, hence the undominated *CN which disallows the occurrence of a cluster of a consonant and a nasal is relevant. Also, the undominated constraints *[b] and *[p] which inhibit the occurrence of the bilabial stops are appropriate besides the *CODA constraint that is consistently undominated. To evaluate candidates and determine the optimum, OT's markedness constraints must interact with the faithfulness constraints. So, we can propose MAX-IO_{SEG} and DEP-IO(V) which are anti-deletion and anti-insertion respectively. Besides, there is also feature change in terms of voice and continuant. Hence, IDENT-IO_{VOI/CONT} is a relevant faithfulness constraint. The constraints will dominate each other as follows in tableau (4.11b):

*CODA, *CN, *[b], *[p] >> *OBSVOI >> MAX-IO_{SEG}, DEP-IO(V), IDENT-IO_{VOI/CONT}

(4.11b) /'bæptɪzm/ → [e.βa.ti.so] 'baptism'

/'bæptɪzm/	*COD A	*CN	*[b]	*[p]	*OBS VOI	MAX-IO SEG	DEP- IO(V)	IDENT- IO _{VOI/CONT}
a. [e.βa.pu.ti.zo]				*!	*	*	**	*
b. ☞ [e.βa.ti.so]						*	*	**
c. [e.ba.ti.so]			*!			*	*	*
d. [bæp.tɪzm]	*!	*	*	*	*			

The markedness constraints *CODA, *CN, *[b], *[p] and *OBSVOI are ranked high in the language and they dominate the faithfulness constraints. Thus, candidate (d) suffers fatal elimination because it violates all of them. Candidate (b) is the winner although it violates all the low ranked faithfulness constraints. In fact, it deletes some segments, allows feature change and allows the insertion of vowels to make the output fit the Ekegusii open syllabicity. As for candidate (c), it does not fare well either. It allows the parsing of the bilabial plosive which is not in the Ekegusii inventory besides violating the faithfulness constraints, hence, it is eliminated. Lastly, candidate (a) violates two of the high ranked markedness constraints besides the faithfulness constraints which Ekegusii ranks lowly. Thus, it is eliminated

4.2.5 Adaptation of English Consonant /l/ to Ekegusii's /r/

English Input	Ekegusii Output	English Gloss
/ˈkælɪndə/	[ekare ⁿ da]	‘calendar’
/gælən/	[eɣarani]	‘gallon’
/ləʊn/	[eroni]	‘loan’
/lɒk/	[eroki]	‘lock’
/ˈlɔːjə/	[erɔja]	‘lawyer’
/ˈtrɒli/	[eturori]	‘trolley’
/ˈtaʊəl/	[etaurɔ]	‘towel’

The alveolar trill /r/ is found in the Ekegusii inventory and so it is the closest substitute to the alveolar lateral approximant /l/ in terms of place of articulation. Besides, both are coronal, sonorants, alveolars, anteriors and liquid sounds. In addition, trills make better onsets than laterals due to their relative low sonority and laterality is a marked feature across languages, in fact medial release of airflow is preferred over lateral. Thus, Ekegusii substitution of the lateral for the trill is no surprise. In the adaptation of the lateral approximant, Ekegusii imposes a constraint on the loanwords; *[LAT] which is a markedness constraint besides the undominated *CODA in the adaptation of ‘trolley’ /ˈtrɒli/ as [eturori]. Also, cluster consonants are not tolerated in Ekegusii; hence, *CO_{ONS} is invoked. These constraints demand structural markedness of output representation, therefore, they are balanced with faithfulness constraints which demand similarity of output to the input. On these, we posit feature change which the output violates: IDENT-IO_{LAT}, there is also insertion, making DEP-IO(V) to be relevant. The faithfulness constraints formulated are dominated as illustrated in tableau (4.12).

*CODA, *[LAT], *CO_{ONS} >> DEP-IO(V), IDENT-IO_{LAT}

(4.12) /'trɔli/ → [eturori] 'trolley'

/'trɔli/	*CODA	*[LAT]	*CO _{ONS}	DEP-IO(V)	IDENT-IO _{LAT}
a.  [e.tu.ro.ri]				*	*
b. [e.tro.ri]			*!		*
c. [e.tro.li]	*!	*			
d. ['trɔ.li]		*!	*		

Candidate (a) is the optimal form because it satisfies the markedness universal constraints of *CODA, *[LAT] and *CO_{ONS} which prohibits coda consonants, laterals and complex onset clusters respectively but violates the faithfulness constraint DEP-IO(V) and IDENT-IO_{LAT} which are ranked low in the constraint hierarchy in Ekegusii. On the other hand, candidate (c) and (d) violate two of the high ranked constraints which are serious violations, thus they are eliminated. As for candidate (b), it violates one markedness constraint *CO_{ONS} and one faithfulness constraint IDENT-IO_{LAT}, hence it does not survive. OT stipulates that perfect forms are non-existent since every output form will violate at least some constraint. The optimal form wins by minimally violating the low ranked constraints.

4.2.6 Adaptation of English Manner-contour Consonants

Manner-contour consonants are single segments but, in some cases, they have two distinguishable articulations and their constriction changes half-way through (Gussenhoven & Jacobs, 2005). Ekegusii which is a Bantu language has a number of manner-contour consonants. These are prenasalized stops; consonants which begin as

nasals and end like plosives at the same place of articulation. Conversely, English has affricates and although it distinguishes nasals like /m/ and stops like /p/ in some phonetic environment, they are prenasalized.

English Input	Ekegusii Output	English Gloss
/stæmp/	[esita ^m bu]	‘stamp’
/'trʌmpɪt/	[etaru ^m beta]	‘trumpet’
/'kʌmpəni/	[eka ^m bani]	‘company’
/kæmp/	[eka ^m bi]	‘camp’
/tæŋk/	[eta ^ŋ gi]	‘tank’
/bæŋk/	[eβe ^ŋ gi]	‘bank’
/'blæŋkɪt/	[oβora ^ŋ geti]	‘blanket’
/'redʒɪstə/	[erecesita]	‘register’
/'kæbɪdʒ/	[ekaβɪci]	‘cabbage’
/'ʃɑ:dʒə/	[ecaca]	‘charger’
/'sɪrɪndʒ/	[esire ⁿ ci]	‘syringe’
/'dʒʌmpə/	[eca ^m ba]	‘jumper’
/dʒu:s/	[ecuisi]	‘juice’
/'dʒækɪt/	[ecaketi]	‘jacket’
/dʒʌg/	[ecaki]	‘jug’

The data reveals that ‘mp’ is substituted with /^mb/ and the English /ŋk/ is replaced by /ⁿg/ in Ekegusii. In both instances, between the donor and recipient language there is both voice and nasal assimilation because of post-nasal voicing leading to the formation of prenasalized stops. The formation of prenasalized stops is a phenomenon that is attested across Bantu languages (Katamba, 1996). For instance, in the adaptation of ‘trumpet’ /trʌmpɪt/ as [etaru^mbeta], the cluster is simplified so as not to violate Ekegusii’s syllable structure. The markedness constraint; *CO_{ONS} is relevant in order to prohibit a sequence of a consonant and an obstruent. Also, *CODA is undominated to ensure adherence to open syllabicity. Moreover, Ekegusii imposes a constraint that bars the occurrence of voiceless obstruents after nasals. This is the markedness constraint *NC_o. Further, this constraint dominates the faithfulness constraints because the

voiceless obstruent acquires the [+voice] feature of the nasal hence, bringing a disparity between the input and the output. The faithfulness constraint invoked will be IDENT-IO_{VOICE}. In addition, the voiceless stops acquire the nasal feature so the constraint IDENT-IO_{NASAL} is relevant. Lastly, the output allows insertion which is prohibited by DEP-IO(V); hence, the faithfulness constraint is relevant. The constraints will be ranked as follows:

*CODA, *CO_{ONS} >> *N_Ç >> IDENT-IO_{VOI/NAS}, DEP-IO(V)

(4.13a) / trΛmpit / → [etaru^mbeta] ‘trumpet’

/ trΛmpit /	*CODA	*CO _{ONS}	*N _Ç	IDENT- IO _{VOI/NAS}	DEP- IO(V)
a. [trΛ.mpit]	*!	*	*		
b. [e.ta.ru.mpe.ta]			*!		**
c.  [e.ta.ru. ^m be.ta]				**	**
d. [e.tru. ^m be.ta]		*!		**	*

Tableau (4.13a) indicates that the optimal candidate is (c) simply because it does not violate the high ranked undominated markedness constraints *CODA and *CO_{ONS} as well as allowing the voiceless obstruent to undergo voicing and acquire the nasal features, therefore, conforming to the high ranked markedness constraint *N_Ç. Candidate (b) violates high ranked *N_Ç constraint which disallows post nasal devoicing which is not prevalent in Ekegusii, hence, it is eliminated. On the other hand, candidate

(d) is eliminated because of strict dominance of the high ranked markedness constraints *CO_{ONS} which it violates besides the low ranked faithfulness constraints. Lastly, candidate (a) is the most disharmonic. Though it does not violate any of the low ranked faithfulness constraints, it violates all the high ranked markedness constraints: *CODA, *CO_{ONS} and *N_Ç which prohibit coda, cluster consonants and post nasal devoicing.

In another adaptation, the English input /bæŋk/ is adapted as [eβe^ŋgi]. OT's constraints can explain this adaptation. First, the undominated markedness constraint *CODA which triggers a repair via vowel epenthesis is proposed. Ekegusii further bans the voiced bilabial plosive; hence, *[b] constraint is appropriate. Thirdly, there is post nasal voicing; consequently, the constraint *N_Ç is relevant. All these are markedness constraints which are counterbalanced by faithfulness constraints. In this input versus output mapping, we propose feature change; IDENT_{VOI/NAS/CONT} and DEP-IO(V) which is anti-epenthesis. The constraints will be ranked as: *CODA, *[b] >> *N_Ç >> IDENT_{VOI/NAS/CONT}, DEP-IO(V)

(4.13b) /bæŋk/ → [eβe^ŋgi] 'bank'

/bæŋk/	*CODA	*[b]	*N _Ç	IDENT- IO _{VOI/NAS/CONT}	DEP-IO(V)
a. [bæŋk]	*!	*	*		
b. [e.βe.ŋki]			*!	*	*
c.  [e.βe. ^ŋ gi]				***	*
d. [e.be. ^ŋ gi]		*!		**	*

Tableau (4.13b), indicates that the optimal candidate is (c). Though it violates the low ranked constraints which are IDENT-IO_{VOI/NAS/CONT} which prohibits feature change and DEP-IO(V) which curtails insertion, it satisfies the high ranked markedness constraints by allowing the voiceless obstruent to undergo voicing and acquire the nasal features therefore, conforming to the high ranked markedness constraint; *N_ɔ, allows vowel epenthesis so as not to violate *CODA which is undominated and replaces the voiced bilabial plosive /b/ with the bilabial fricative which is the attested form in the language. On the other hand, candidate (b) and (d) are isoharmonic. They each violate one of the high ranked markedness constraints; *N_ɔ and *[b] respectively besides the low ranked constraints, so they are eliminated. Lastly, candidate (a) is the most disharmonic. Though it does not violate any of the faithfulness constraints which are ranked low in the Ekegusii language, it violates the high ranked markedness constraints which are *CODA, *[b] and *N_ɔ, thus, it is eliminated.

In addition, there is the adaptation of voiceless palatal plosive /c/ in place of the voiced post-alveolar affricate /dʒ/. The two consonants are very similar in terms of place of articulation; palatals save for voice. Equally, both belong to the natural class of obstruents and voiceless obstruents are the unmarked category. Therefore, Ekegusii adapts the most unmarked cross linguistically. Hence, the constraint we can posit to account for the preference of the voiceless obstruent is *[OBSVOI] which militates against voicing of obstruents, besides the *CODA constraint which inhibits codas and is undominated in the language. In the adaptation of /'kæbɪdʒ/ 'cabbage' adapted as [e.ka.βi.ci], it can be noted that Ekegusii replaces the voiced bilabial stop /b/ with the

bilabial fricative /β/ which is the attested form in the language. Thus, the undominated *[b] is an appropriate constraint. In addition, Ekegusii outputs indicated that there is eminent insertion of vowels and feature change. Therefore, the faithfulness constraints DEP-IO(V) and IDENT-IO_{VOI/CONT} are relevant and will be ranked as follows:

*CODA, *[b] >> *[OBSVOI] >> DEP-IO(V), IDENT-IO_{VOI/CONT}

(4.14) /'kæbɪdʒ/ → [e.kə.βi.ci] 'cabbage

/'kæbɪdʒ/	*CODA	*[b]	*[OBSVOI]	DEP-IO-V	IDENT-IO _{VOI/CONT}
a.  [e.kə.βi.ci]				*	**
b. [kə.βi.dʒi]			*!	*	*
c. [e. kə. bi.tʃi]		*!	*	*	*
d. [kæ.bɪdʒ]	*!	*	*		

Candidate (a) incurs the less serious violations for the faithfulness constraints which demand structural similarity between input and output and are ranked low in the language. As a result, it is said to be optimal. As for candidate (b) it allows for obstruent voicing which is disallowed in this adaptation. As a result, it is eliminated. Candidate (c) violates two of the high ranked constraints: *[b] and *OBSVOI; hence, it is ruled out. (d) is the most disharmonic candidate. It not only violates the high ranked *CODA, which prohibits coda consonants and *[b] which disallows bilabial plosive but also *OBSVOI by allowing the occurrence of the voiced post-alveolar affricate /dʒ/; a sound that is not attested in the language, therefore it is eliminated. The Ekegusii's

markedness constraints obviously dominate the faithfulness constraints which ensure correspondence between the underlying form and the surface forms.

4.3 Phonological Processes in Adaptation

Loanword adaptation is primarily a phonological process, the donor words undergo phonological repairs to adapt to the segmental, phonotactic, supra-segmental and morphological constraints of the recipient (Tsvetkov & Dyer, 2016). By borrowing words from English, Ekegusii speakers are faced with sound combinations which are not present in the language's inventory. Thus, Ekegusii phonological constraints define the well-formedness of the output forms by repairing the illicit structures. In an effort to repair, various phonological processes were realized and are discussed.

4.3.1 Epenthesis

Epenthesis is the addition of one or more sound segments to a word (Sarkar, 2012). There are three types of epenthesis: excrescence, which is the addition of consonants; prothesis, addition of vowels at the initial point of a word usually with a phonotactic motivation while anaptyxis is addition of vowel between two consonants. Epenthesis is also known as insertion. No instance of excrescence was observed. Equally, Ekegusii did not witness any instance of prothesis. However, the insertion of 'e' in word initial is a morphological rather than phonotactic realization whereby Ekegusii allows pre-prefixation. Anaptyxis was observed in the following:

English Input	Ekegusii Output	English Gloss
/ˈfæktəri/	[eβayitori]	‘factory’
/breɪk/	[eβureki]	‘brake’
/ˈbɔʊlt/	[eβoriti]	‘bolt’
/ˈbælkəni/	[eβarikoni]	‘balcony’
/ˈbɪskɪt/	[eyesuyuti]	‘biscuit’
/ˈhelɪkɒptə/	[erikoβita]	‘helicopter’
/ˈhedˈmaːstə/	[etumasita]	‘headmaster’
/ˈhɒtpɒt/	[eotiβoti]	‘hotpot’
/ˈkɜːtn/	[ekateni]	‘curtain’
/kənˈdʌktə/	[ekoˈdayita]	‘conductor’
/ˈklɪnɪk/	[ekiriniki]	‘clinic’
/desk/	[etesiki]	‘desk’
/ˈfɪftɪ/	[βiβiti]	‘fifty’
/glɑːs/	[ekerasi]	‘glass’
/ˈredʒɪstə/	[erecesita]	‘register’
/ˈlesn/	[ereseni]	‘lesson’
/steɪdʒ/	[esiteci]	‘stage’
/steɪʃn/	[esiteseni]	‘station’
/slɪp/	[esiriβu]	‘slip’
sku:l/	[esukuru]	‘school’
/ˈsekrətəri/	[esekeretari]	‘secretary’
/ˈtreɪlə/	[eturɛra]	‘trailer’
[ˈplæstɪk]	[eβurasitiki]	‘plastic’

Cluster consonants either on syllable onset or coda are broken by inserting a vowel. There appears to be no predictable pattern governing the kind of vowel to be inserted to break the consonant clusters. However, what is clear are the constraints forbidding clusters at either positions. An explanation for this could be because complex onsets are cross linguistically marked and therefore restricted in occurrence or completely banned in some languages. Therefore, we invoke the following the markedness constraints as proposed by Nandelenga (2013); *CO, *CN, *CL and *CG all of which are part of a family of constraints subsumed under the general anti-cluster constraint; *COMPLEX_{ONSET}. *CG in particular is low ranked because Ekegusii language allows it. In an input like /redʒɪstə/ ‘register’ adapted as [e.re.ce.si.ta], there is a cluster of

consonant and an obstruent which is repaired via vowel epenthesis. So, we can propose *CO_{ONS} besides the undominated markedness constraint *CODA. Equally, the schwa is not attested in the Ekegusii language; hence, *[REDUCED-V] is relevant. There is also devoicing of the post alveolar fricative, therefore, *[OBSVOI] can be invoked. Moreover, DEP-IO(V) constraint which forbids epenthesis is witnessed and as well as feature change so that IDENT-IO_{VOI}, will be strictly dominated as follows:

*CODA, *CO_{ONS}, *[REDUCED-V] >> *[OBSVOI] >> DEP-IO-V, IDENT-IO_{VOI}

(4.15) /redʒɪstə/ → [e.re.ce.si.ta] ‘register’

[redʒɪstə]	*CO _{ONS}	*CODA	*[REDUCED-V]	*[OBSVOI]	DEP-IO-V	IDENT-IO _{VOI}
a. [re.ɖʒɪ.stə]	*!		*	*		
b. [e.re.ce.si.ta]					*	*
c. [re.ɪɖʒ.si.ta]		*!		*	*	
d. [e.re.ce.sta]	*!					*

The well-formedness conditions prevail over the faithfulness conditions in Ekegusii. Consequently, though candidate (b) violates a faithfulness DEP-IO(V) constraint which demands structural similarity between input and output as well as IDENT-IO_{VOI} which forbids feature change, it is the optimal form. Candidate (a) is the most disharmonic. It violates three of the markedness constraints by allowing a complex onset, a schwa and obstruent voicing that the Ekegusii language ranks highly. So, it does not survive. On the other hand, candidate (c) does not fare well either. It incurs serious violations by

violating the high ranked *CODA and *OBSVOI constraints which are ranked high in the language's hierarchy of constraints. Thus, it is eliminated. Candidate (d) is less harmonic compared with the optimal since it allows a complex onset. Hence, it is eliminated. Evidently, Ekegusii attaches more importance to cluster simplification and no coda than structural similarity between input and output.

4.3.2 Deletion

Deletion is the omission of one or more sounds. Mostly, when deletion occurs it may affect consonants, vowels, weak syllables or it may occur simply to break a consonant cluster. Deletion may take three forms. Aphaeresis, loss of a segment at the beginning of a word; syncope, the internal deletion of segments, that is, it occurs within a word and lastly, apocope which is the loss of the final consonant.

Aphaeresis was observed in the mapping of the following loanwords to Ekegusii.

English Input	Ekegusii Output	English Gloss
/he.li.kɒ.ptə/	[e.ri.ko.βi.ta]	'helicopter'
/'hed.'ma:.stə/	[e.tu.ma.si.ta]	'headmaster'
/'hɒt.pɒt/	[e.o.ti.βo.ti]	'hotpot'
/ha:f.tɜ:m/	[e.a.βu.ta.mu]	'half term'

The consonant /h/ is a voiceless glottal fricative. It functions in English essentially as a voiceless syllable-initial phoneme. In fact, some words have a silent /h/ in their spelling; however, because of its place of articulation (glottis) and being voiceless it is hardly audible. Besides, the Ekegusii inventory lacks it. Therefore, in the mapping it is easily deleted at word initial.

Further, syncope was evidenced in the following segments.

English Input	Ekegusii Output	English Gloss
a. /'bæp.tɪzm/	[e.βa.ti.so]	'baptism'
b. /bæp.'taɪz/	[βa.ti.sa]	'baptize'
c. /'dɪs.trɪkt/	[e.ti.si.ri.yi.ti]	'district'

In segment (a), there is the deletion of /m/, in (b) /p/ is deleted while in (c), sound /t/ is deleted. In all the instances, the motivation is to break a consonant cluster. Clearly, Ekegusii language disallows cluster consonants hence, a constraint prohibiting their occurrence is ranked higher in the hierarchy and is undominated i.e. *CN just like *CODA which disallows coda consonants. Moreover, from the input output mapping of /'bæptɪzm/ as [e.βa.ti.so] in Ekegusii, there is obstruent devoicing, thus the markedness constraints *OBSVOI is relevant as well as the deletion of the bilabial plosive /p/, hence *[p] constraint. Also, there is no correspondence between the input and output as deletion of consonants occurs as well as insertion of vowels. MAX-IO(C) as well as DEP-IO(V) are the consequent constraints and also IDENT-IO_{VOI/CONT} which disallow feature change. They will be ranked as follows:

*CODA, *CN, *[p] >> *OBSVOI >> MAX-IO(C), DEP-IO(V), IDENT-IO_{VOI/CONT}

(4.16) /'bæptɪzm/ → [e.βa.ti.so] 'baptism'

/'bæptɪzm/	*CODA	*CN	*[p]	*OBSVOI	MAX-IO(C)	DEP-IO(V)	IDENT-IO _{VOI/CONT}
a. [bæp.tɪzm]	*!	*	*	*			
b.  [e.βa.ti.so]					**	*	**
c. [e.ba.ti.ɪs]	*!		*		**	*	*
d. [e.βa.ti.zmo]		*!		*	*	*	*

The markedness constraints in this case dominate the faithfulness in Ekegusii. As a result, candidate (b) is the optimal form although it violates the faithfulness constraints which require some similarity between input and output. Nevertheless, (c) and (d) are eliminated. In fact, the two of them are isoharmonic, each of them violates two of the high ranked markedness constraints; *CODA and *[p] as well as *CN and *OBSVOI respectively which are ranked high in Ekegusii's hierarchy of constraints besides the faithfulness. As for candidate (a), it is the most disharmonic. It allows a coda worse still a complex coda, it has the voiceless bilabial plosive which is not attested in the language and allows the occurrence of a voiced obstruent; all these are constraints ranked very high in the language hierarchy. Evidently, Ekegusii's phonotactics pays more attention to structural markedness than similarity of input and output forms in borrowing phonemic segments.

No instance of apocope was observed in Ekegusii.

4.3.3 Devoicing/ Strengthening and Voicing/ Weakening

When a consonant that is normally voiced is pronounced without vocal-fold vibration in some context, it is said to be strengthened or devoiced (Gussenhoven & Jacobs, 2005). Conversely, weakening or voicing occurs when a segment without vocal-fold vibration changes to be voiced in some contexts. Strengthening was observed in Ekegusii borrowing where the loanword had segments which are voiced, but when mapping occurred, they were devoiced.

English Input	Ekegusii Output	English Gloss
/ˈbæptɪzəm/	[eβatiso]	‘baptism’
/ˈhedˈmɑːstə/	[etumasita]	‘headmaster’
/ˈkæbɪdʒ/	[ekaβici]	‘cabbage’
/ˈdʌstə/	[etasita]	‘duster’
/desk/	[etesiki]	‘desk’
/ˈtʃɑːdʒə/	[ecaca]	‘charger’
/ˈdʒʌmpə/	[eca ^m ba]	‘jumper’
/dʒuːs/	[ecuisi]	‘juice’
/ˈdʒækɪt/	[ecaketi]	‘jacket’
/ˈtreʒərə/	[eturesara]	‘treasurer’

Voiced obstruents are strengthened or devoiced when the loanwords are adapted in Ekegusii. For instance, /z/ is adapted as /s/, /d/ as /t/, /ʒ/ is adapted as /s/ and /dʒ/ as /c/. In all the instances, the motivation was absence of the voiced obstruents in the Ekegusii inventory besides the fact that voiceless sounds are unmarked, hence cross-linguistically preferred over the voiced sounds. Thus, this adaptation of voiced obstruents can be accounted for using OT. First, a constraint that prohibits obstruent voicing is imposed on the incoming loan. This is *[OBSVOI] in addition to the undominated *CODA constraint. Like for instance in the mapping of /ˈdʌstə/ as [etasita], there is the undominated *[REDUCED-V] which is relevant. Ekegusii disallows cluster consonants

as a result it is repaired through vowel epenthesis. In this case, CO_{ONS} markedness constraint is proposed to evaluate the outputs further. Similarly, there is feature change whereby the inputs undergo devoicing. This we can invoke the faithfulness constraint of IDENT-IO_{VOI}. Furthermore, in most of the outputs there is vowel insertion so as to break consonant clusters. Therefore, DEP-IO(V) will be a relevant faithfulness constraint to account for the epenthesis. So, the constraints will be ranked as follows:

*CODA, *CO_{ONS}, *[REDUCED] >> *[OBSVOI] >> DEP-IO(V), IDENT-IO_{VOI}.

Tableau (4.17) presents the appropriate data to illustrate this obstruent devoicing.

(4.17) /'dʌstə/ → [etasita] 'duster'

/'dʌstə/	*CODA	*CO _{ONS}	*[REDUCED-V]	*[OBSVOI]	DEP-IO-V	IDENT-IO _{VOI}
a.  [e.ta.si.ta]					*	*
b. [dʌ.stə]		*!	*	*		
c. [e.da.si.at]	*!			*	*	
d. [e.ta.stə]		*!	*			*

Tableau (4.17) indicates that candidate (b) is the most disharmonic. It violates three of the high ranked markedness constraints which include: a complex cluster, realizes a voiced obstruent /d/ and has a schwa which is not attested in the language. Hence, it is thrown out. Candidate (a) incurs the less serious violations of the faithfulness constraints which demand structural similarity between input and output and are ranked low in the language. As a result, it is said to be optimal. However, (c) and (d) are isoharmonic,

they each incur two of the more serious violations which are *CODA, *OBSVOI and *COONS, *[REDUCED-V] respectively besides the faithfulness constraints which are ranked low in the language constraints hierarchy. The Ekegusii's markedness constraints in this case dominate the faithfulness constraints which ensure correspondence between the underlying form and the surface forms.

On the other hand, weakening or voicing was observed in Ekegusii borrowing where the loanword had segments which are voiceless, but when mapping occurred, they became voiced as follows.

English Input	Ekegusii Output	English Gloss
/tʃi:f/	[eciβu]	'chief'
/refə'rendəm/	[eriβera ⁿ damu]	'referendum'
/'trænsfɜ:/	[eturansiβa]	'transfer'
/'petrəl/	[εβetirori]	'petrol'
/'helikɒptə/	[erikoβita]	'helicopter'
/'kʌpəd/	[ekaβati]	'cupboard'
/'kæptɪn/	[ekaβuteni]	'captain'
/'prɪnsəpəl/	[eβuri ⁿ siβo]	'principal'
/'tæksɪ/	[etayisi]	'taxi'

Voicing/ weakening takes place where sounds /f/, /p/ and /k/ become /β/, /β/ and /ɣ/ respectively. Equally, in this case, the motivation is due to the absence of the voiceless sounds in Ekegusii apart from the mapping of /k/ to /ɣ/ whereby both sounds are in the Ekegusii language. OT can account for this voicing in that we invoke the markedness constraints *[CONT, LAB/DENT] and *[p] to punish the segments that have the voiceless labiodental fricative and the voiceless bilabial plosive. Thus, if we illustrate using inputs like /tʃi:f/ which is adapted as [eciβu] 'chief' and /'petrəl/ adapted as [εβetirori] 'petrol' it can be observed that *CODA constraint is undominated while

*CO_{ONS} is also invoked to punish complex cluster consonants. Further, the input has a schwa and a lateral; both of which are unattested in the language. Consequently, *[REDUCED-V] is proposed to punish segments with the reduced vowel and *[LAT] to punish segments which bear the laterals. Moreover, the outputs allow insertion of vowels and feature change. Therefore, the faithfulness constraints DEP-IO(V) and IDENT-IO_{VOI/LONG} are invoked. The constraints will be ranked as follows in tableau (4.18a and b)

(4.18a) *CODA, *[CONT, LAB-DENT] >> DEP-IO(V), IDENT-IO_{VOI/LONG}

(4.18b) *CODA, *[p], *CO_{ONS} *[REDUCED-V], *[LAT] >> DEP-IO-V, IDENT-IO_{VOICE}

(4.18a) /ɸi:f/ → [eciβu] ‘chief’

/ɸi:f/	*CODA	*[CONT, LAB-DENT]	DEP-IO(V)	IDENT-IO _{VOI/LONG}
a.  [e.ci.βu]			*	*
b. [ɸi:f]	*!	*		
c. [e. ci.fu]		*!	*	
d. [eɸ.βu]	*!		*	*

From tableau (4.18a), candidate (b) is the most disharmonic. It violates the high ranked markedness constraints *CODA and *[CONT, LAB-DENT]. Hence, it is eliminated. On the other hand, candidate (a) is the optimal. It satisfies the high ranked markedness constraints; *CODA and *[CONT, LAB-DENT] but violates the low ranked faithfulness constraints DEP-IO(V) which prohibits vowel insertion and IDENT-

IO_{VOI/LONG} which disallows feature change. Thus, it minimally survives. As for candidates (c) and (d), they each violate the high ranked *[CONT-LAB-DENT] and *CODA respectively, thus they are eliminated.

(4.18b) /'petrəl/ → [εβɛtirori] 'petrol'

/'petrəl/	*CODA	*[p]	*CO _{ONS}	*[REDU CED-V]	*[LAT]	DEP- IO(V)	IDENT- IO _{VOI/LAT}
a. ↗ [ε.βɛ.ti.ro.ri]						**	*
b. [pe.trəl]	*!	*	*	*	*		
c. [ε.βɛ.tro.li]			*!		*	*	**
d. [ε.pe.ti.ro.ri]		*!				**	

Candidate (b) is the most disharmonic. It violates all the high ranked markedness constraints *CODA, *[P], *CO_{ONS}, *[REDUCED-V] and *[LAT]; therefore, it does not survive. Conversely, candidate (a) is the optimal. Though it violates the low ranked faithfulness constraints IDENT-IO_{VOI/LAT} and DEP-IO(V), it satisfies the high ranked markedness constraints; *CODA, *[P], *CO_{ONSET}, *[REDUCED-V] and *[LAT]. Candidate (c) allows a complex onset and the occurrence of a lateral sound that is not in the Ekegusii inventory besides violating the low ranked faithfulness constraints, thus, it does not survive. Lastly, candidate (d) is less harmonic compared to the winner. Whereas it violates just one markedness constraint *[p] which Ekegusii language attaches importance to, and one faithfulness constraint by allowing vowel insertion, on this account it is eliminated. In this instance, the markedness constraints dominate the faithfulness constraints.

4.3.4 Resyllabification

Syllabification results in a difference in the number of syllables in the input verses the output form. In the data from loan adaptation in Ekegusii, English monosyllabic loans are replaced by disyllables and vowels inserted between or at the end of consonant which lead to an increase in the number of syllables in the output.

English Input	Ekegusii Output	English Gloss
/pɪn/	[e.βi.ni]	‘pin’
/bɒks/	[e.βo.ɣi.si]	‘box’
/breɪk/	[e.βu.re.ki]	‘brake’
/bæŋk/	[e.βe. ^ɰ gi]	‘bank’
/tæŋk/	[e.ta. ^ɰ gi]	‘tank’
/vest/	[e.βe.si.ti]	‘vest’
/'kʊ.ʃən/	[e.ko.so.ni]	‘cushion’
/keɪk/	[e.ke.ki]	‘cake’
/ti:m/	[e.ti.mu]	‘team’
/'træns.fɜ:/	[e.tu.ra. ^ɰ si.βa]	‘transfer’
/'θɜ:məs/	[e.ta.mo.si]	‘thermos’

From the syllabification in Ekegusii, a number of constraints are imposed on the loanwords. First, *CODA constraint, whereby Ekegusii forbids the presence of consonants in the coda. Consequently, loans that are monosyllabic and have codas are repaired via vowel insertion leading to an addition of syllables. Secondly, Ekegusii forbids onset cluster consonants except [CG] hence, a *CO, *CN and *CL constraints are applied accordingly to evaluate inputs. Where there is violation there is simplification via vowel insertion leading to syllabification. Hence, in an input like /vest/ ‘vest’ adapted as [e.βe.si.ti]; another markedness constraints that applies is *[CONT, LAB-DENT] which prohibits the occurrence of the voiced labial dental fricative. Further, in an attempt to make the loans fit in the Ekegusii phonology, the input violates the faithfulness conditions like DEP-IO(V) which forbids insertion of

vowels and IDENT-IO_{CONT} which forbids feature change. The constraints will be ranked as follows: *CODA, *CO, *[CONT-LAB-DENT] >> DEP-IO(V), IDENT-IO_{CONT}. This is presented in tableau (4.19).

(4.19) /vest/ → [e.βe.si.ti] ‘vest’

/vest/	*CODA	*CO	*[CONT, LAB-DENT]	DEP-IO(V)	IDENT-IO _{CONT}
a. [vest]	*!	*	*		
b. [e.βe.sti]		*!		*	*
c. [e.βe.si.ti]				**	*
d [e.ve.si.ti]			*!	**	

Tableau (4.19) shows that candidate (a) is the most disharmonic. It violates all the high ranked constraints; *CODA, *CO and *[CONT, LAB-DENT], thus, it is eliminated. Candidates (b) and (d) are isoharmonic. Each of them violates one of the high ranked otherwise markedness constraints *CO that forbids complex clusters and *[CONT, LAB-DENT] which disallows the occurrence of the labia dental fricative respectively as well as the low ranked faithfulness constraints hence, they too are eliminated. However, (c) minimally violates the low ranked faithfulness conditions in the Ekegusii thus, it optimally wins.

4.3.5 Substitution

Substitution is a phonological process that systematically changes a particular type of speech sound and replaces it with another (Sarkar, 2012). Data already presented indicates that substitution was very rampant in Ekegusii. Different English vocalic and consonants were mapped to Ekegusii as follows. The long /i:/ was realized as /ɪ/, /æ/ as /e/, /ɑ/ or /ɛ/, /ɜ:/ was realized as /ɑ/, /ɒ/ as /o/ and one instance where it changed to /e/ and /ɒ/, /ɔ:/, /ʌ/ as /u/. The consonant sounds also were substituted as follows. /b/, /p/, /v/, /f/ were adapted to /β/, /g/ was realized as /ɣ/, /k/, /ŋg/ in different environments, /d/, /θ/ changed to /t/ while /z/, /ʃ/ /ʒ/ were adapted as /s and /l/ as /r/. As for manner-contour consonants ‘mp’ was realized as /^mb/ in Ekegusii, while the English /ŋk/ was replaced by /^ŋg/ in Ekegusii. In all the instances of substitution, the phonological constraints of the Ekegusii language determined the substitution. We can use OT’s constraints to account for vowel and consonant substitution. For vowels, we consider an input like /^hθɜ:məs/ adapted as [etamosi] ‘thermos’. Specifically, the long mid open central unrounded vowel /ɜ:/ is adapted as the open front unrounded vowel /a/. This two share the features [-back], [-round]. Equally, the schwa is not attested in the Ekegusii language; therefore, the markedness constraint *[REDUCED-V] and IDENT-IO_{LONG} which is a faithfulness constraint that forbids feature change are proposed so as to punish any outputs that are illicit. Moreover, the *CODA constraint is undominated in the language thus, it is relevant. Further, it can be observed that Ekegusii repairs the voiceless dental fricative /θ/ to the voiceless alveolar stop /t/. The markedness constraint *[CONT, DENT] can account for this adaptation. In addition, the faithfulness

constraints DEP-IO(V) can be proposed to account for the epenthesis in Ekegusii as well as IDENT-IO_{CONT}. The constraints are ranked as follows in tableau (4.20a):

*CODA, * [REDUCED-V], *[CONT-DENT] >> DEP-IO(V), IDENT-IO_{LONG/CONT}

(4.20a) /'θɜ:məs/ → [etamosi] 'thermos'

/'θɜ:məs/	*CODA	*[REDUCED-V]	*[CONT, DENT]	DEP-IO(V)	IDENT-IO _{LONG/CONT}
a.  [e.ta.mo.si]				*	**
b. [θɜ:məs]	*!	*	*		
c. [e.ta.mə.si]		*!		*	**
d. [e.ta.mos]	*!				**

According to tableau (4.20a), candidate (b) is the most disharmonic. It not only violates the coda condition but also allows for the occurrence of a schwa and the dental fricative violating the high ranked markedness constraint *CODA, *[REDUCED-V] and *[CONT, DENT] which Ekegusii ranks highly. As for candidates (c) and (d), they violate the high ranked markedness constraints *[REDUCED-V] and *CODA both of which are ranked very high in the Ekegusii besides the low ranked DEP-IO(V) and IDENT-IO_{LONG/CONT} which they violate. Therefore, they are thrown out. Lastly, candidate (a) is the most harmonic, although it allows insertion of vowels, violating the faithfulness DEP-IO(V) and feature change; IDENT-IO_{LONG/CONT}, it meets the requirements of the high ranked undominated markedness constraints. Markedness

constraints that demand structural markedness between the input and output dominate the faithfulness constraints that demand similarity between input and output.

On consonant substitution, we can consider the input /ʃilɪŋ/ adapted as [esiri^ŋgi] ‘shilling’. In this adaptation, the voiceless alveolar fricative /s/ substitutes the voiceless post alveolar fricative /ʃ/. Similarly, the trill /r/ is adapted in place of /l/. OT’s markedness and faithfulness constraints can be invoked to account for this phenomenon. First, we propose the *CODA constraint that is undominated in the Ekegusii language. Secondly, the two sounds are coronals. Hence, we can formulate a markedness constraint *[j] which is undominated just like *CODA. Thirdly, we can invoke another markedness constraint *[LAT] that prohibits the occurrence of a lateral sound in Ekegusii. In addition, there is no correspondence between the input and the output. In fact, there is vowel insertion making the output violate DEP-IO(V) as well as feature change DEP-IO_{LAT/NAS/DISTR}. The constraints will be ranked as follows in tableau (4.20b) *CODA, *[j], *[LAT] >> DEP-IO(V), IDENT-IO_{LAT/NAS/DISTR}

(4.20b) /ʃilɪŋ/ → [esiri^ŋgi] ‘shilling’

/ʃilɪŋ/	*CODA	*[j]	*[LAT]	DEP-IO(V)	IDENT-IO _{LAT/NAS/DISTR}
a. [ʃi.lɪŋ]	*!	*	*		
b. [e.ʃi.ri.ŋgi]		*!		*	**
c. [e.si.ri.ŋgi]				*	***
d. [e.si.li.ŋgi]			*!	*	**

As shown in tableau (4.20b), the markedness constraints dominate the faithfulness constraints. Thus, Ekegusii ranks the markedness language constraints of *CODA, *[] and *[LAT] higher than DEP-IO-V and IDENT-IO_{LAT/NAS/DISTR}. Consequently, candidate (c) is the most harmonic since it does not violate any of these constraints that Ekegusii language ranks highly. As for candidate (b) and (d), they are isoharmonic. They each violate one of the high ranked markedness constraint, *[] and *[LAT] besides the faithfulness constraints, as a result they are eliminated. Candidate (a) is the most disharmonic, it violates all the markedness constraints by allowing a coda, a lateral and voiceless post alveolar fricative sound in the output, all which are not attested in the language. Hence, it is eliminated.

4.3.6 Monophthongization

Monophthongs are simple vocalic sounds that have a steady state articulation; that is, tongue, lips and jaw are meant to achieve -however brief- a stable configuration called a target configuration (Clark & Yallop, 2007). Monophthongization occurs when diphthongs are reduced to simple pure vowels.

English Input	Ekegusii Output	English Gloss
/keɪk/	[ekeki]	‘cake’
/breɪk/	[eβureki]	‘brake’
/'beɪkəri/	[eβekeri]	‘bakery’
/'eɪkə/	[ε.ε.ka]	‘acre’
/'rəʊlə/	[erorɛ]	‘roller’
/rɪ'məʊt/	[erimoti]	‘remote’
/'bəɪrəʊ/	[eβiro]	‘biro’
/'laɪsəns/	[eresesi]	‘license’

In all the instances of monophthongization, the motivation is absence of the diphthong in the Ekegusii language. Subsequently, the pure vowels that replace the diphthongs have a similarity with those on the loanword. A case in point is /ei/ changes to either /e/ or /ɛ/, /əʊ/ is adapted as /o/ while /əɪ/ and /aɪ/ are substituted by /ɪ/ and /e/ respectively. OT can account for this monophthongization in Ekegusii. Let us illustrate using /əʊ/ which is simply reduced to /o/ with which it shares features [+round, +back]. OT's universal markedness constraint *CODA and the language's well-formedness constraints *DIPH, accounts for the adaptation of /o/ in Ekegusii. Further, from the data it can be inferred that different Ekegusii outputs allow for the epenthesis of vowels and feature change. Thus, we can add the faithfulness constraints of DEP-IO(V) and IDENT-IO_{DIPH} to account for these changes in case of /rɪ'məʊt/ being adapted as [erimoti] 'remote'. The constraints are ranked as follows:

*CODA, *DIPH >> MAX-IO_{SEG} >> DEP-IO(V), IDENT-IO_{DIPH}

(4.21) /rɪ'məʊt/ → [erimoti] 'remote'

/rɪ'məʊt/	*CODA	*DIPH	MAX-IO _{SEG}	DEP-IO(V)	IDENT-IO _{DIPH}
a. [rɪ.məʊt]	*!	*			
b.  [e.ri.mo.ti]				*	*
c. [e.ri.mo]			*!		*
d. [e.ri.məʊ.ti]		*!		*	

Tableau (4.21) indicates that candidate (a) is the most disharmonic. It violates both of the high ranked *CODA constraint and the *DIPH constraint that prohibits the occurrence of coda consonants and diphthongs respectively. On the other hand, (b) is the most harmonic despite the fact that it violates DEP-IO(V) by allowing insertion of vowels and changes the diphthong to a simple vowel. As for candidate (d) it violates the high ranked markedness constraint *DIPH and the low faithfulness constraints, hence it is eliminated. Candidate (c) does not fare well either, though it violates a faithfulness constraint; MAX-IO_{SEG}, this constraint is ranked above other faithfulness constraints although it is dominated by the markedness constraints. Hence, candidate (c) is eliminated.

4.3.7 Lenition

This is a phonological process that alters sound segments by weakening them. For instance, consonants can be changed from voiceless to voiced, plosives to fricatives sounds among others. For vowels, both back and front vowels are stronger than central vowels. Thus, if they are altered to the latter they are weakened. The following are some of the cases of lenition identified in the data collected.

English Input	Ekegusii Output	English Gloss
/ˈbændɪdʒ/	[eβa ⁿ deci]	‘bandage’
/ˈbætəri/	[eβetɪrɪ]	‘battery’
/breɪk/	[eβureki]	‘brake’
/ˈbeɪkəri/	[eβekeri]	‘bakery’
/bæŋk/	[eβe ⁿ gi]	‘bank’
/ˈbæptɪzəm/	[eβatɪso]	‘baptism’

The voiced bilabial plosive /b/ is weakened to the voiced bilabial fricative /β/ which is the closest in the Ekegusii inventory. Similarly, the voiced palatal affricate /dʒ/ is adapted as the voiceless palatal plosive /c/ while the central vowel /ə/ is adapted as the mid low open vowel /e/. In the adaptation of /'bændɪdʒ/ as [eβaⁿdeci], though the voice is maintained it is weakened in the mapping of bilabial plosive /b/ to the bilabial fricative /β/ while the voice is lost in the adaptation of /dʒ/ as /c/. This adaptation can be accounted for using OT. Ekegusii language imposes a markedness constraint on the incoming loan that they should not violate *OBSVOI besides the universal constraint of *CODA which is ranked high in the hierarchy. Besides, the voiced bilabial plosive /b/ is not attested in the Ekegusii language. Hence, the markedness constraint *[b] is relevant. All these proposed are markedness constraints which have to interact with faithfulness constraints. Thus, from the input output mapping there is feature change in terms of voice and a stop changing to a continuant; IDENT_{VOI/CONT} and DEP-IO(V) which is anti-epenthesis are invoked. The constraints will be ranked as:

*CODA, *[b] >> *OBSVOI >> IDENT_{VOI/CONT}, DEP-IO(V)

(4.23) /'bændɪdʒ/ → [eβaⁿdeci] 'bandage'

/'bændɪdʒ/	*CODA	*[b]	*OBSVOI	IDENT-IO _{VOI/CONT}	DEP-IO(V)
a. [bæ.ndɪdʒ]	*!	*	*		
b. [e.ba. ⁿ di.dʒɪ]		*!	*		*
c. ↗ [e.βa. ⁿ de.ci]				**	*
d. [e.βa. ⁿ dedʒ]	*!		*	*	

Tableau (4.23) shows that (c) is the most harmonic. Although it violates the low ranked constraints which are IDENT-IO_{VOI/CONT} which prohibit feature change and DEP-IO(V) which forbids insertion, it satisfies the high ranked markedness constraints which are *CODA, *[b] and *OBSVOI. On the other hand, candidate (b) and (d) are isoharmonic. They each violate two of the high ranked markedness constraints; *[b], *OBSVOI and *CODA, *OBSVOI respectively, hence they are eliminated. Lastly, candidate (a) is the most disharmonic. Though it does not violate any of the faithfulness constraints which are ranked low in the Ekegusii language, it violates all the high ranked markedness constraints which are *CODA, *[b] and *OBSVOI, thus it is eliminated.

The findings on the phonological processes manifested when Ekegusii borrows from English agree with those explored in the reviewed literature. For instance, Ndambuki (2013) establishes that insertion, deletion and feature are evident in his analysis of Kikamba nativized loanwords. Similarly, Iribemwangi and Karuru (2012) find that deletion, preservation, substitution and importation are the phonological processes employed by the Gĩ-Gĩchũgũ dialect of Gĩkũyũ language when borrowing from Kiswahili. Also, Saleh and Jarrah (2013) established that phonological changes observed in Madin Hijazi Arabic (MHA) include: epenthesis, consonant voicing, vowel change and re-syllabification so as to maintain the MHA phonological structures.

Similarly, Zafaranlu and Hashemi (2011) found that insertion and prothesis, were the main phonological processes reported on Russian loanwords adaptation in Persian. In addition, Faezeh and Zafarantu (2013) established that initial consonant clusters of

German loanwords are broken through vowel epenthesis which is mostly identical to the vowel of the second syllable and reduction in diphthongs as well as the substitution of phonemes.

Other findings which are very relevant to these findings are by Sarkar (2012). He notes that loanwords undergo phonological changes at two levels: segmental level and syllabic level. At the segmental level, loaned consonants in the onset and coda positions undergo two processes; deletion and substitution. At the syllabic level, compensatory lengthening, consonant deletion, feature change, vowel epenthesis, cluster tolerance and germination are the phonological processes reported Sarkar reports in Bangla. Likewise, Ayuni (2012) in the Indonesian borrowed words, reports epenthesis followed by change of sound strength and deletion of a whole segment as being very frequent.

Fossi (2012) findings include: cluster simplification, consonant vowel reinterpretation, schwa deletion, voicing, devoicing and tone insertion. As for the Kiswahili language which belongs to the Bantu language family, Chacha (2009) notes that loanwords from Arabic to Kiswahili undergo: vowel epenthesis to repair syllables, feature change, consonant deletion and cluster tolerance. He further adds that Kiswahili's open syllabicity (NOCODA) faithfulness constraint dominates the markedness of the sonority hierarchy (SON-SEQ) in the borrowed words. However, consonant clusters are tolerated in Kiswahili something that does not occur in Ekegusii borrowing.

Thus, it can be concluded that borrowing across languages (related or unrelated) reports similar if not the same phonological processes only that the processes attested in one language are a subset of the universally exhibited processes.

4.4 Phonotactics in Ekegusii Language that Constrain Borrowing

Phonotactics or constraints is the way sound segments combine in a particular language (Cruttenden, 2014). These phonotactics will be discussed at two levels: segmental and syllabic levels.

4.4.1 Segmental Level Constraints

At the segmental level, we focus on the Ekegusii phonotactics that constrain the occurrence of individual phonemes and how this further constrains borrowing.

4.4.1.1 Vocalic Phonemes

Ekegusii has seven vocalic phonemes: /a/, /ɛ/, /e/, /i/, /ɔ/, /o/ and /u/. They occur word initially, medially and final positions. The language does not have diphthongs or triphthongs. In the event that a loanword has either a diphthong or a triphthong, they are monophthongized so as to repair the illicit structures. So, we can propose that Ekegusii has a phonotactic that forbids the occurrence of diphthongs/triphthongs; hence, a constraint [*DIPH] can be posited to account for it. We illustrate using ‘license’ where /ai/ in /'lɪsəns/ is adapted as [eresesi] whereby the diphthong is simply reduced to /e/ with which it shares the features [-round, -back]. OT’s universal markedness constraint *CODA and *DIPH, accounts for the adaptation of /e/ in Ekegusii. Further, the schwa and the lateral which are not attested in the language can be accounted for using the

markedness constraint *[REDUCED-V] and *LAT respectively. Moreover, from the data it can be inferred that Ekegusii output allows for the epenthesis of vowels, consonant deletion and feature change. Thus, we can add the faithfulness constraints of DEP-IO(V), IDENT-IO_{DIPH/LAT} and MAX-IO(C). So, the constraints can be ranked as follows:

*CODA, *DIPH, *[REDUCED-V], *LAT >> MAX-IO(C) >> DEP-IO(V), IDENT-IO_{DIPH/LAT}

(4.24) /'laisəns/ → [eresesi] 'license'

/'laisəns/	*CODA	*DIPH	*[REDUCED-V]	*LAT	MAX-IO _(C)	DEP-IO(V)	IDENT-IO _{DIPH/LAT}
a. [ˈlɑi.səns]	*!	*	*	*			
b.  [e.re.se.si]					*	*	**
c. [le.sə.si]			*!	*	*	*	*
d. [lɑi.se.nsi]		*!		*		*	

Tableau (4.24) indicates that candidate (a) is the most disharmonic. It violates all the high ranked markedness constraints in Ekegusii, hence it is eliminated. On the other hand, (b) is the most harmonic despite the fact that it violates DEP-IO(V) by allowing insertion of a vowel, feature change and deletion of a consonant. Both candidate (c) and (d) are isoharmonic. Each of them violates two of the high ranked markedness constraints: *[REDUCED-V], *LAT and *DIPH, *LAT respectively besides the low

ranked faithfulness constraints. Accordingly, both are thrown out. The markedness constraints that demand structural well-formedness between input and output dominate faithfulness constraints that demand similarity between input and output.

4.4.1.2 Consonantal Sounds

Ekegusii has 20 consonantal sounds. They are: /^mb/, /t/, /ⁿt/, /ⁿd/, /k/, /ⁿk/, /ⁿg/, /β/, /s/, /ⁿs/, /ɣ/, /c/, /ⁿc/, /m/, /n/, /ɲ/, /ŋ/, /w/, /ɾ/ and /j/. All these consonants may occur as onset followed by a vowel but never as coda consonants. Therefore, the phonotactic constraint we propose here which constrains the occurrence of individual consonant segments is *CODA. Moreover, Ekegusii forbids the occurrence of cluster consonants. However, complex onsets are cross linguistically marked and therefore restricted in occurrence or not allowed completely. In fact, following Nandelenga's (2013) harmonic scale on the Lubukusu which is a Bantu language, we can also propose a harmonic scale for Ekegusii.

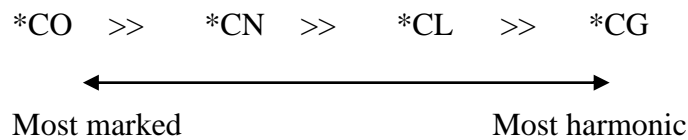

C stands for a consonant, O for obstruent, N for nasal, L for liquid while G for a glide. Thus, *CO is a combination of a consonant and an obstruent, *CN is a consonant and a nasal while *CL is a consonant and a liquid. These three are not attested in the Ekegusii language hence, are marked. *CG is a combination of a consonant and a glide. Though this combination is attested in the language, its occurrence is restricted. There seems to be a phonotactic that militates against the occurrence of a complex onset. Therefore, we

can propose *CO, *CN, *CL and *CG as the phonotactics in OT to account for the phenomenon of complex onsets in Ekegusii language. In the event that a loanword has cluster consonants, they are repaired via vowel epenthesis as follows.

English Input	Ekegusii Output	English Gloss
/ˈeɪprən/	[e.a.βuroni]	‘apron’
/breɪk/	[eβureki]	‘brake’
/ˈbəʊlt/	[eβoriti]	‘bolt’
/ˈbɑːθrʊm/	[eβaturumu]	‘bathroom’
/ˈblæŋkɪt/	[oβora ^ɰ geti]	‘blanket’
/ˈbælkəni/	[eβarikoni]	‘balcony’
/ˈbeɪsn/	[eβeseni]	‘basin’
/ˈbɪskɪt/	[eyesuyuti]	‘biscuit’
/ˈhelɪkɒptə/	[erikoβita]	‘helicopter’
/ˈhɒtpɒt/	[e.o.tiβoti]	‘hotpot’
/ˈtʃɪmni/	[ecimuni]	‘chimney’
/ˈkæptɪn/	[ekaβuteni]	‘captain’
/ˈkɜːtn/	[ekateni]	‘curtain’

All these are possible repairs which occurred where we had cluster consonants. So, if we pick one instance to illustrate; [ˈtʃɪmni] ‘chimney’ adapted as [ecimuni], the phonotactic constraint already proposed in this category is *CODA which is consistently undominated and *CN which prohibits the occurrence of a consonant and a nasal as complex clusters. Our input will further be subjected to the universal constraints of faithfulness; MAX-IO_{SEG} which prohibit deletion of any segments and DEP-IO(V) which prohibits epenthesis of vowels. Thus, the constraints will be ranked as: *CODA, *CN >> MAX-IO_{SEG} >> DEP-IO(V)

(4.25) /tʃimni/ → [e.ci.mu.ni] ‘chimney’

/tʃimni/	*CODA	*CN	MAX-IO _{SEG}	DEP-IO(V)
a. [tʃi.mni]		*!		
b. ↗ [e.ci.mu.ni]				*
c. [e.tʃi.umn].	*!	*		
d. [e.ci.mu]			*!	

Candidate (c) is the most disharmonic. It violates all the high ranked markedness constraints; *CODA and *CN which forbids coda consonants and clusters consonants. As for candidate (a) and (d) they are thrown out because they violate *CN, and MAX-IO_{SEG} respectively, constraints that Ekegusii attaches importance to. Though MAX-IO_{SEG} is a faithfulness constraint, it is ranked above all other faithfulness constraints. Hence, (d) is eliminated though it does not violate any of the markedness constraints. Finally, (b) though not perfect, it minimally violates the low ranked faithfulness constraint DEP-IO(V) in this category, hence it is the optimal.

Besides the phonotactics; *CODA and *CN which constrain the way consonants occur and combine, there are more phonotactics which constrain specific occurrence of different consonantal segments. This means that though Ekegusii has different categories of consonants, under each category there is a phonotactic which constraints what must occur and what must not. We will discuss them under the following sub-

categories which are in reference to the overriding feature in the Ekegusii adaptation: labials, velars, sibilants, approximants and manner-contours and interdentalals.

Labials

Labial is a feature referring to the use of the upper and lower lip in articulation. The resulting sounds are known as labials. For our description we distinguish between bilabial (both lips involved) and labio-dental (lower lip and upper teeth). In this category Ekegusii has /β/, /^mb/ /m/ and /w/ only. We eliminate /^mb/ because it is prenasalized and /m/ and /w/ are both in the English inventory. Only /β/ remains as the closest for all other English bilabials and labio-dentals. No wonder then, /β/ is adapted where we have loanwords that have /b/, /p/, /f/ and /v/. The Ekegusii phonotactics we can propose here are *[b] and *[p] which constrain the occurrence of labials. On the other hand, for labial dentals we can propose *[CONT, LAB-DENT] which can be incorporated as a phonotactic that bans the occurrence of segments that are not parsed as the bilabial fricative. This constraint ensures that labial dental fricatives which are not attested in the language do not occur. In fact, words which have illicit sound segments are changed to conform to what is available in Ekegusii. Also relevant is the undominated *CODA constraint in Ekegusii. In addition, in an input like /'trænsfɜ:/ 'transfer' which is adapted as [e.tu.ra.ⁿsi.βa], other relevant constraints will be *CO_{ONS} will forbids cluster onsets in this case a consonant and an obstruent. Further, the input will be subjected to universal faithfulness constraints of IDENT-IO_{LONG/VOI/CONT} and DEP-IO(V). Thus, the constraints will be ranked as follows:

*CODA, *CO_{ONS}, *[CONT, LAB-DENT] >> IDENT-IO_{VOI/LONG/CONT}, DEP-IO(V)

(4.26) /'trænsfɜː/ → [e.tu.ra.ⁿsi.βa] 'transfer'

/'trænsfɜː/	*CODA	*CO _{ONS}	*[CONT, LAB-DENT]	IDENT- IO _{LONG/VOI/CONT}	DEP-IO(V)
a. [e.tu.ra. ⁿ si.βa]				***	**
b. [e.tu.ra. ⁿ si.fa]			*!	*	**
c. [træns.fɜː]	*!	*	*		
d. [e.tra. ⁿ si.βa]		*!		***	*

Candidate (a) is the most optimal, though it violates the faithfulness constraints of IDENT-IO_{VOI/LONG/CONT} and DEP-IO(V) which allow feature change in terms of voice, vowel length and continuant as well as vowel insertion respectively, it satisfies the high ranked universal markedness constraint of *CODA, *CO_{ONS} and *[CONT, LAB-DENT]. Conversely, candidate (c) is the most disharmonic, it violates all the high ranked constraints of markedness of CODA, *CO_{ONS} and *[CONT, LAB-DENT]. Candidate (b) and (c) equally violate the *[CONT, LAB-DENT] and *CO_{ONS} which ban the labial dental fricative and onset clusters respectively; thus, making them unfit options. In this adaptation, universal markedness constraints dominate the faithfulness constraints.

Velars

The velar refers to the region extending from the start of the soft-palate or velum, back as far as the uvular. Sounds produced when the back of tongue is raised so that it touches the velum are called velars (Ladefoged & Johnson, 2011). Ekegusii has the

following velars: /k/, /^hk/, /^hg/, /ɣ/ and /ŋ/. Both /k/ and /ŋ/ are found in the English inventory. However, the voiced velar stop /g/ is not in the Ekegusii inventory, instead it is prenasalized and tolerated. Evidence from the data revealed that /g/ is mapped into Ekegusii's /ɣ/, /k/, and /^hg/. Evidently, all these are velar sounds. So, we propose a phonotactic constraint which governs the mapping of a velar to another that is present in the Ekegusii; *[g], so that any loan that has a velar sound which is not present in the Ekegusii will necessarily be mapped to another velar so as to conform to what the language has. An input like 'gas' /gæs/, adapted as [e.ɣa.sɪ], this phonotactic *[g] can be used to evaluate it as a prospective loanword besides the universal markedness constraint of *CODA. The faithfulness constraints which the input and output mapping is seen to violate are DEP-IO(V) which forbids insertion and IDENT-IO_{CONT} which prohibits feature change. MAX-IO_{SEG} which forbids deletion is also relevant. The constraints will then be ranked as follows:

*CODA, *[g] >> MAX-IO_{SEG} >> IDENT-IO_{CONT}, DEP-IO(V)

(4.27) /gæs/ → [e.ɣa.sɪ] 'gas'

/gæs/	*CODA	*[g]	MAX-IO _{SEG}	IDENT-IO _{CONT}	DEP-IO(V)
a.  [e.ɣa.sɪ]				*	*
b. [gæs]	*!	*			
c. [e. ga.sɪ]		*!			*
d. [e. ɣa]			*!	*	

Candidate (a) is the optimal form since it minimally violates the low ranked faithfulness constraints, IDENT-IO_{CONT} and DEP-IO(V). However, the same cannot be said for (b) which violates the universal markedness constraints *CODA and *[g] which Ekegusii ranks highly. Hence, it is eliminated. Candidate (c) on the hand, violates not only the *[g] constraint that disallows the occurrence of a velar stop /g/ which is not in the Ekegusii inventory but also allows for insertion though ranked lowly in the language. Lastly is candidate (d) which is eliminated because it violates MAX-IO_{SEG} which prohibits deletion. Though it is a faithfulness constraint, Ekegusii ranks it high; hence, it dominates other faithfulness constraints but is dominated by the markedness constraints. From this data, we can say Ekegusii's phonotactic constraints *CODA and *[g] rank higher than the faithfulness constraint MAX-IO_{SEG}, which then dominate IDENT-IO_{VOICE} and DEP-IO(V).

Sibilants

Sibilants are sounds that have more acoustic energy; that is, greater loudness at a higher pitch, with a more obvious hiss than the other fricatives (Ladefoged & Johnson, 2011). Besides the prenasalized sibilants, /ⁿs/ and /ⁿc/, Ekegusii only has /s/ and /c/ as potential phonemes for adaptations. Consequently, English sibilants /z/, /ʃ/ /ʒ/ are adapted as /s/ while /dʒ/ is changed to /c/. Here we can propose the phonotactics that constrains the adaptation; that is a strident that is voiceless must be adapted. Therefore, *OBSVOI and *[ʃ] are the appropriate phonotactics which constrain this Ekegusii adaptation. These phonotactics besides the undominated *CODA can be used to account for the mapping of an input like /gə'zet/ 'gazette' adapted as [e.ɣa.se.tɪ]. Further, it can be noted that

from the input- output mapping *[g] which forbids the voiced velar plosive is a relevant constraint. Other faithfulness constraints which will evaluate the potential candidate may include: DEP-IO(V) and IDENT_{VOI/CONT}. The constraints will be dominated as:

*CODA, *[g], >> *OBSVOI >> DEP-IO(V), IDENT_{VOI/CONT}

(4.28a) /gə'zet/ → [e.ɣa.se.ti] 'gazette'

/gə'zet/	*CODA	*[g]	*OBSVOI	DEP-IO(V)	IDENT _{VOI/CONT}
a.  [e.ɣa.se.ti]				*	**
b. [gə.zet]	*!	*	*		
c. [e.ɣa.ze.ti]			*!	*	*
d. [e.ga.ze.ti]		*!	*	*	

Candidate (a) is the most harmonic, in fact, it incurs the least violations of the faithfulness constraints which demand structural similarity between input and output, thus, it is the optimal form. Candidate (c) is less harmonic than the winner. It violates the high ranked markedness *OBSVOI besides allowing for insertion and feature change. Candidate (d) violates two of the high ranked markedness constraints; *[g] and *OBSVOI; thus, it is eliminated. Candidate (b) is the most disharmonic. It violates all the high ranked markedness constraints; *CODA, *[g] and *OBSVOI, therefore, it is eliminated.

Similarly, another input like 'jumper' /dʒʌmpə/ which is adapted as [e.ca.^mba] is subject to the same Ekegusii constraints. First, Ekegusii prohibits post nasal devoicing; therefore, the constraint *NÇ is proposed. Secondly, there is obstruent devoicing which

sees the adaptation of /dʒ/ as [c]. The markedness constraint *OBSVOI is appropriate to account for this adaptation. Also, the schwa is not attested in the Ekegusii inventory. Thus, the undominated markedness constraint *[REDUCED-V] is relevant. The faithfulness constraints which can further evaluate the input and output mapping is IDENT-IO_{VOI/NAS} which prohibit feature change. The constraints are ranked as follows:

*CODA, *[REDUCED-V] >> *OBSVOI, *N_Ç >> DEP-IO(V), IDENT_{VOI/NAS}

(4.28b) /dʒΛmpə/ → [e.ca.^mba] ‘jumper’

/dʒΛmpə/	*CODA	*[REDUCED-V]	*OBSV OI	*N _Ç	IDENT- IO _{VOI}	IDENT _{NAS}
a.  [e.ca. ^m ba]					*	*
b. [e. ca. mpa]				*!	*	
c. [edʒ. ^m ba]	*!		*			*
d. [dʒΛmpə]		*!	*	*		

Candidate (a) is the optimal form, though it violates the low ranked universal constraint IDENT-IO_{VOI/NAS}. Whereas (d) is the most disharmonic having violated all the high ranked markedness constraints including, *CODA and *[REDUCED-V] as well as *OBSVOI and *N_Ç that Ekegusii attaches importance to. Candidate (c) does not do well either as it violates the high ranked *CODA as well as *OBSVOI besides the faithfulness constraints, hence, it is eliminated. As for candidate (b) it is less harmonic. It violates *N_Ç which forbids post nasal devoicing which Ekegusii ranks highly in this adaptation.

Approximants

Approximants derive their name from the approximation of the articulators which give rise to a light or near-contact, the airstream being so weak that no friction is produced (Gussenhoven & Jacobs, 2005). There are two approximants in Ekegusii; /w/ and /j/ as well as the liquid /r/. The two approximants in Ekegusii /w/ and /j/ were not frequent in the loanwords. However, in terms of their occurrence they result from height assimilation from the preceding vowel, leading to the formation of a glide. For instance, loanwords like ‘sweater’ /'swetə/ adapted as [e.swe.ⁿta] results from the underlying form [e.su.e.nta]. Similarly, ‘computer’ /kəm'pjʊ:tə/ adapted as [e.ko.^mbjʊ.ta] results from the underlying form [e.ko.mbi.u.ta]. All the three, /j/, /w/, /r/ are found in English, however, the lateral approximant /l/ is not in Ekegusii. In its adaptation, the trill is realized. We can propose a phonotactic which constraints its adaptation; the loanwords must not violate the phonotactic *[LAT]. From the input like /ləʊn/ adapted as [e.ro.ni], it can further be noted that Ekegusii prohibits diphthongs therefore, the constraint *DIPH is relevant. These constraints demand structural markedness of output representation in addition to the consistent *CODA universal constraint that is undominated. Further, we propose the universal faithfulness constraint which demand similarity of output to the input DEP-IO(V) and IDENT-IO_{LAT/DIPH} which forbid feature change. The constraints will be ranked as follows: *CODA, *[LAT], *DIPH >> DEP-IO(V), IDENT-IO_{LAT/DIPH}

(4.29) /ləʊn/ → [e.ro.ni] ‘loan’

/ləʊn/	*CODA	*[LAT]	*DIPH	DEP- IO(V)	IDENT- IO _{LAT/DIPH}
a. ↗ [e.ro.ni]				*	**
b. [e.lo.ni]		*!		*	*
c. [e.ron]	*!				**
d. [ləʊn]	*!	*	*		

Candidate (d) is the most disharmonic. It violates all the high ranked markedness constraints *CODA, *[LAT] and *DIPH that require structural well formedness of input and output. Candidate (a) is the optimal form because it satisfies the markedness universal constraint *CODA and the language’s constraint *[LAT] and *DIPH making it the most harmonic among others although it violates the faithfulness constraints DEP-IO(V) by allowing vowel insertion and IDENT-IO_{LAT/DIPH} by allowing feature change. Conversely, candidate (b) allows the occurrence of a lateral sound in its output, a phoneme that is non-existent in the Ekegusii inventory. As for (c) it does not fare well either, it violates the *CODA condition, thus it is rendered unfit.

Manner-contour Consonants

Ekegusii which is a Bantu language has a number of manner-contour consonants. These include: prenasalized stops: /^mb/, /ⁿt/, /ⁿd/, /ⁿc/, /ⁿk/ and /ⁿg/, one that has a nasal and fricative: /ⁿs/. English on the other hand, in this category only has ‘mp’ and /ŋk/

combinations which result from a phonological process of regressive assimilation. From the substitution process discussed already, it can be noted that /^mb/ in Ekegusii replaces ‘mp’ in English while the /ⁿk/ is replaced by /ⁿg/. In this category of prenasalized stops, we can note that Ekegusii has phonotactics which militate against the occurrence of the prenasalized stops. Hence, we can propose a phonotactic from the universal markedness constraint *N_Ç which forbids post nasal devoicing. In other words, the unmarked is the post nasal voicing. For instance, in an input like ‘stamp’ /stæmp/ adapted as [e.si.ta.^mbu], *N_Ç phonotactic can be used to evaluate the output. In addition, there is the *CODA constraint that is undominated in the language as well as *CO_{ONS} which disallows cluster consonants. On the faithfulness constraints, it can be observed that the input undergoes voicing, nasalization and there is apparent vowel insertion. Therefore, the constraints: IDENT-IO_{VOI/NAS}, and DEP-IO(V) can all be used to evaluate potential candidates and will be ranked in tableau (4.30a) as follows: *CODA, *CO_{ONS} >> *N_Ç, >> IDENT-IO_{VOI/NAS}, DEP-IO(V)

(4.30a) /stæmp/ → [e.si.ta.^mbu] ‘stamp’

/stæmp/	*CODA	CO _{ONS}	*N _Ç	IDENT-IO _{VOI/NAS}	DEP-IO(V)
a. [stæmp]	*!	*	*		
b.  [e.si.ta. ^m bu]				**	**
c. [e.si.ta.mpu]			*!		**
d. [e.sta. ^m bu]		*!		**	*

In tableau (4.30a), it is indicated clearly that candidate (a) is the most disharmonic. It violates all the high ranked markedness constraints of *CODA, *CO_{ONS} and *N_Ḷ, thus, it is eliminated. On the other hand, candidate (b) is the optimal form although it violates all the faithfulness constraints that demand similarity between input and output. Equally, candidates (c) and (d) are rendered unfit since they violate the high ranked markedness constraints *N_Ḷ and *CO_{ONS} respectively besides violating the low ranked faithfulness constraints.

Another input we can consider in this category of manner- contours is the adaptation of /tæŋk/ ‘tank’ as [e.ta.ŋgi]. As already mentioned, Ekegusii language has a phonotactic that prohibits post nasal devoicing. Thus, we can propose the universal markedness constraint *N_Ḷ which forbids post nasal devoicing. Secondly, *CODA is consistently undominated in the Ekegusii language. As for the faithfulness constraints, there is no similarity between input and output. First, we can propose DEP-IO(V) which is anti-insertion as well as MAX-IO_{SEG} which is anti-deletion. Further, the output can be subjected to IDENT-IO_{VOI/NAS}, which curtail feature change. All constraints in tableau (4.30b) will be ranked as follows: *CODA, >> *N_Ḷ, >> MAX-IO_{SEG} >> IDENT-IO_{VOI/NAS}, DEP-IO(V)

(4.30b) /tæŋk/ → [e.ta.ŋgi] ‘tank’

/tæŋk/	*CODA	*NÇ	MAX-IO _{SEG}	IDENT-IO _{VOI/NAS}	DEP-IO(V)
a. [tæŋk]	*!	*			
b.  [e.ta.ŋgi]				**	*
c. [e.ta.ŋkɪ]		*!			*
d. [e.ŋgi]			*!	**	

In tableau (4.30b), candidate (a) is the most disharmonic. Though it does not violate any of the low ranked faithfulness constraints; it violates two of the high ranked markedness constraints of *CODA and *NÇ, hence, it is eliminated. On the other hand, candidate (b) is the optimal form although it violates all the faithfulness constraints; IDENT-IO_{VOI/NAS} and DEP-IO(V) which foreclose feature change and vowel insertion. As for candidate (c) it is eliminated because it violates the high ranked markedness constraints; *NÇ and the faithfulness constraint DEP-IO(V) which curtails insertion. Lastly candidate (d) is rendered unfit because it violates MAX-IO_{SEG}. Though a faithfulness constraint, Ekegusii ranks it higher than other faithfulness constraints, but lower than markedness constraints.

Still on English manner contours, /dʒ/ is changed to /c/ in Ekegusii. There seems to be a phonotactic that imposes a constraint in this adaptation: shared features being that they are both palatals in terms of place of articulation, obstruents and [-cont]. It can be

deduced that Ekegusii has a phonotactic that prohibits obstruent voicing and the universal markedness constraint *[OBSVOI] can be proposed to account for this adaptation. Besides, voiceless obstruents are preferred cross linguistically while the voiced ones are marked, therefore cross-linguistically avoided. This phonotactic can be used to evaluate an input like ‘syringe’ /^hsɪrɪndʒ/ adapted as [e.si.re.ⁿci]. Another relevant markedness constraint that can be invoked is *CODA which is an undominated markedness constraint as well as the faithfulness constraints which include MAX-IO_{SEG}, which forecloses deletion, DEP-IO(V) that forbids insertion and IDENT-IO_{VOI} which curtails feature change in terms of voice. The constraints will be ranked as follows:

*CODA >> *[OBSVOI] >> MAX-IO_{SEG} >> DEP-IO(V), DEP-IO_{VOI}. Tableau (4.30c) shows this interaction.

(4.30c) /^hsɪrɪndʒ/ → [e.si.re.ⁿci] ‘syringe’

/ ^h sɪrɪndʒ/	*CODA	*OBSVOI	MAX-IO _{SEG}	IDENT-IO _{VOI}	DEP-IO(V)
a.  [e.si.re. ⁿ ci]				*	*
b. [e.sɪ.re.nɪ]			*!		*
c. [e.sɪ.re.ndʒɪ]		*!			*
d. [sɪ.rɪ ⁿ dʒ]	*!	*			

Candidate (a) is the most harmonic having satisfied the universal markedness constraints *CODA and *[OBSVOI] as well as the faithfulness constraint MAX-IO_{SEG} which Ekegusii ranks higher. However, it violates the low ranked faithfulness constraints of DEP-IO(V) that forbids insertion and IDENT-IO_{VOI} which prohibits feature change. On the other hand, (d) emerges as the most disharmonic. It violates two

of the high ranked markedness constraints; *CODA and allows obstruent voicing in the output. Candidate (c) and (b) are isoharmonic. They violate MAX-IO_{SEG} which is ranked high in Ekegusii and *CODA which is undominated respectively. So markedness constraints strictly dominate faithfulness constraints.

Interdentals

Ekegusii does not have any interdentals. In fact, the voiceless dental fricative /θ/ realized in loanwords is adopted as /t/. Both /t/ and /θ/ are obstruents. The unmarked voiceless obstruents are preferred cross linguistically while the voiced are avoided. Therefore, the mapping of /θ/ to /t/ is the most natural given that the former is non-existent in the Ekegusii inventory. Besides, voiceless stops are the unmarked segments relative to fricatives; hence, their adaptation (Paradis & Prunet, 1991).

In this adaptation, Ekegusii seems to impose a phonotactic constraint *[CONT, DENT] which prohibits the occurrence of voiceless or voiced interdentals which are not in the Ekegusii inventory. Secondly, from the loanword /'θɜ:məs/ 'thermos' adapted as [etamosi]; Ekegusii has a phonotactic constraint that militates against the occurrence of a schwa. Therefore, *[REDUCED-V] can be proposed to account for its adaptation. Further, to avoid the occurrence of consonants at the coda which is disallowed in Ekegusii, *CODA constraint is invoked. Other faithfulness constraints which are relevant in this case are IDENT-IO_{CONT/LONG} which prohibit feature change and DEP-IO(V) which disallows vowels insertion as shown in tableaux (4.31a and 4.31b). The constraints can be ranked as follows:

*CODA, *[REDUCED-V], *[CONT, DENT], >>DEP-IO(V), IDENT-IO_{CONT/LONG}

(4.31a) /'θɜ:məs/ → [etamosi]

/'θɜ:məs/	*CODA	*[REDUCED-V]	*[CONT-DENT]	DEP-IO(V)	IDENT-IO _{CONT/LONG}
a.  [e.ta.mo.si]				*	**
b. [θɜ:məs]	*!	*	*		
c. [e.θɑ.mo.sɪ]			*!	*	*
d. [e.tɜ:mo.sɪ]		*!		*	*

As shown in tableau (4.31a) candidate (a) incurs the least number of violations on the faithfulness constraints, so it is said to be the optimal. Candidate (b) on the other hand is the most disharmonic. It violates all the high ranked undominated *CODA, *[REDUCED-V] and *[CONT, DENT] constraints by allowing the occurrence of a coda, the interdental sound that does not exist in the Ekegusii inventory as well as the schwa. As for candidate (c) it is eliminated because it violates the high ranked *[CONT, DENT] constraint which prohibits the occurrence of the voiceless interdental fricative. Lastly candidate (d) violates the high ranked universal markedness constraints; *[REDUCED-V] which forbids the occurrence of a schwa hence, it is ruled out.

In another input whereby ‘headmaster’ /'hed'mɑ:stə/ is adapted as [etumasita], Ekegusii has similar phonotactics which constrain this borrowing. For instance, Ekegusii forbids the occurrence of a schwa, the voiceless glottal /h/ and complex cluster consonants. Consequently, the following undominated constraints are proposed: *[REDUCED-V],

*[h] and *CO_{ONS}. In addition, Ekegusii forbids coda consonants therefore, the undominated *CODA relevant. Moreover, there is the devoicing of obstruent which is unmarked cross linguistically. Therefore, *OBSVOI is the proposed markedness constraint. All these are markedness constraints which must interact with faithfulness constraints to determine the optimal. Hence, IDENT-IO_{VOI/LONG} which forecloses feature change and DEP-IO(V) which disallows insertion are proposed. In tableau (4.31b) the constraints dominate each other as follows:

*CODA, *CO_{ONS}, *[REDUCED-V], *[h] >> *[OBSVOI] >> IDENT-IO_{VOI/LONG}, DEP-IO(V)

(4.31b) /'hed'mɑ:stə/ → [etumasita] 'headmaster'

/'hed'mɑ:stə/	*CO DA	*CO ONS	*[REDU CED-V]	*[h]	*[OBS VOI]	IDENT- IO _{VOI/LONG}	DEP- IO(V)
a. [e.tu.ma.si.ta]						**	*
b. [e.tu.ma.sta]		*!				**	
c. [e.dɪ.ma.sɪ.tə]			*!		*!	*	*
d. [hed.mɑ:stə]	*!	*	*	*	*		

Tableau (4.31b) shows that candidate (a) is the most harmonic as it incurs the least number of violations by allowing insertion and feature change, so it is said to be optimal. Candidate (d) is the most disharmonic. It violates all the markedness constraints; *CODA, *CO_{ONSET}, *[REDUCED-V], *[h] and *[OBSVOI] which Ekegusii language ranks highly, hence, it is eliminated. Candidate (b) is less harmonic compared to the winner. It violates the *CO_{ONS} which Ekegusii ranks highly besides

allowing insertion. As for candidate (c) it violates two of the high ranked markedness constraints *CODA and *[OBSVOI] as a result, it is eliminated. The universal markedness constraints dominate the faithfulness constraints.

4.4.2 Syllabic Level Phonotactics.

There are two theories that attempt to define the syllable. First, that the definition is based on properties of sounds, such as sonority (acoustic energy) or prominence (some combination of sonority, length, stress and pitch) (Ladefoged & Johnson, 2011). This theory encounters problems in that some words cannot be accounted for like 'spa'. Second, that a syllable is a unit in the organization and planning of the sounds of an utterance, so that you say a syllable is the smallest possible unit of speech. This definition is also echoed by other scholars who note that a syllable commonly consists of a vocalic peak, which may be accompanied by a consonantal onset or coda (Clark & Yallop, 2007). They further observe that in some languages, every syllable peak is indeed a vowel but other sounds can also form the nucleus of a syllable. For instance, in English where a word ends in an unstressed syllable containing a nasal or a lateral, it can form a syllable when the schwa vowel is deleted. However, this is not the case in Ekegusii where every syllable peak is a vowel. As evidenced from the data on loanwords, it can be deduced that the universally unmarked syllable structure of Ekegusii is a V or CV. Nevertheless, in some special instances, we can have CGV which in this case is a consonant, glide and a vowel. Basically, Ekegusii syllable structure displays three patterns:

V- Vowel only/ onsetless syllable type

CV- Consonant + a vowel

CGV- Consonant + Glide + a vowel

To account for what is permissible and what is not permissible we invoke OT's universal constraints. That all languages have open syllables which are unmarked, meaning syllables must not have codas; secondly, vowels form the peak, not consonants, thirdly, syllables must have onsets (Kager, 1999:9). Following these constraints, we propose the following universal constraints as Ekegusii phonotactics: No coda; *CODA, no peak consonants; *PEAK-C and a syllable must have onset; ONSET. Further, we note that *CODA is undominated because it is never violated in the Ekegusii borrowing. Equally, the nucleus is necessarily a vowel while Ekegusii allows onset and onsetless syllables; hence, *PEAK-C is ranked above ONSET as shown:

*CODA, *PEAK-C >> ONSET.

Evidently, all these (*CODA, *PEAK-C >> ONSET) are markedness constraints. In OT, markedness is counterbalanced by faithfulness conditions which demand similarity between the inputs and outputs. The faithfulness constraints are: MAX-IO_{SEG}, which requires that each segment in the input ('I') has a corresponding segment in the output form ('O'). In other words, deletion is forbidden. Secondly, DEP-IO which requires that each segment in the output form has a corresponding segment in the input form, meaning insertion is prohibited. Thirdly, IDENT(F) which requires that every feature (F) in the input segment is 'identical' to every feature in the output segment; thus, feature change is prohibited (McCarthy and Prince, 1995: McCarthy, 2002, 2004).

Kager (1999) further proposes ALIGN STEM RIGHT- which implies that for every syllable, there must be some stem such that the right edge of the syllable matches the right edge of the stem. Considering that Ekegusii has open syllables, any segment after the vowel is prohibited. Nonetheless, this constraint is similar to *CODA. Kager further adds ALIGN-L which evaluates inputs to ensure they have onsets or not. Therefore, if an input has no onset, inserting a consonant is prohibited and if there is onset, deleting the consonant is prohibited as well. This constraint is similar to ONSET. So, using these constraints, we explore the three syllable types in Ekegusii and how they constrain borrowing.

4.4.2.1 V Syllable Structure

The basic component of the Ekegusii syllable is that it must have a vowel and an optional preceding consonant.

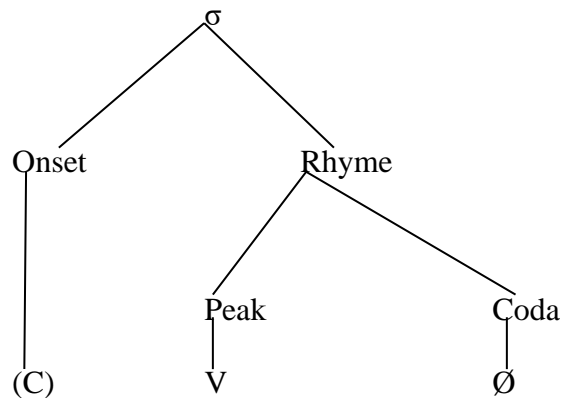

Figure 4.1 V syllable Structure

The figure shows that the syllable has an optional onset meaning it can be null, an obligatory peak that has a vowel and a null coda. The V syllable type was observed in the following borrowed segments. The period indicates a syllable boundary.

English Input	Ekegusii Output	English Gloss
/eɪkə/	[ɛ.ɛ.ka]	‘acre’
/ə'kaʊnt/	[e.a.ka.o.nti]	‘account’
/eəriə/	[e.e.ri.o]	‘aerial’
/fju:z/	[e.βi.u.si]	‘fuse’
/geɪt/	[e.ɣe.i.ta]	‘gate’
/gaʊn/	[e.ɣa.o.ni]	‘gown’
/gɪə/	[e.ɣi.a]	‘gear’
/peɪl/	[e.βe.i.ri]	‘pail’
/waɪn/	[e.wa.i.ni]	‘wine’

From the data, it can be noted that Ekegusii onsetless syllable can occur word initially, medially and word final. This V syllable type can be accounted for using OT’s constraints. We illustrate using the input ‘gate’ /geɪt/ adapted as [e.ɣe.i.ta]. The relevant markedness constraints which evaluate the input and output include: *CODA, *PEAK-C, *[g] and ONSET. In addition, we can propose *DIPH as a relevant undominated markedness constraint.

One of the constraints require inputs to have ONSETS. However, the V syllable type does not have an onset. Therefore, it means this constraint will be dominated by faithfulness constraints that demand similarity between input and output. They include: MAX-IO_{SEG} which forbids deletion, DEP-IO(V) which forbids vowel insertion and IDENT-IO_{CONT} which forbids feature change. ONSET will be dominated as follows.

*CODA, *PEAK-C, *DIPH, *[g] >> MAX-IO_{SEG} >> DEP-IO(V), IDENT-IO_{CONT}/DIPH >> ONSET

(4.32) /geit/ → [e.ɣe.1.ta] ‘gate’

/geit/	*CO DA	*PEA K-C	*DI PH	*[g]	MAX- IO _{SEG}	DEP- IO(V)	IDENT- IO _{CONT/DIPH}	ONS ET
a. [geit]	*!		*	*				
b. [e.ɣe.1.t]		*!				*	**	**
c.  [e.ɣe.1.ta]						**	**	**
d. [e.e.1.ta]					*!	**	*	***

Candidate (c) is the most harmonic, out of the eight constraints; it only minimally violates the low ranked ONSET, IDENT-IO_{CONT/DIPH} and DEP-IO(V) which prohibit syllable onset, feature change and vowel insertion. Hence, it wins optimally. On the other hand, candidate (a) is the most disharmonic. It violates three of the high ranked markedness constraints; *CODA, *DIPH and *[g], which render it unfit. As for candidate (b), it violates the high ranked markedness, PEAK-C besides the faithfulness constraints, hence, it is eliminated. Candidate (d), it does not fare well either. It violates the faithfulness constraint MAX-IO_{SEG} which forbids deletion. This constraint is ranked higher than other faithfulness therefore, rendering the candidate unfit.

Besides, the undominated *CODA, DIPH, *[g] and *PEAK-C, the faithfulness constraints of MAX-IO_{SEG} and DEP-IO(V) dominate the markedness constraint of ONSET and this enables OT to account for the V syllable type in Ekegusii. Moreover, the V syllable type constrains borrowing in Ekegusii in that it determines the repair processes that ensure illicit structures do not occur in Ekegusii borrowing. For instance,

in the event that a loanword has cluster consonants, diphthongs or triphthongs; the V syllable structure does not allow. Consequently, it introduces vowel epenthesis to make loans conform to Ekegusii phonotactics. For instance, in the adaptation of /'eɪ.kə/ as [ɛ.ɛ.ka]; a number of the V syllable is responsible for the reduction of the diphthong and the replacement of the schwa. So that the undominated markedness constraints *DIPH, *[REDUCED-V] and *CODA are relevant to account for the adaptation as well as ONSET although it will be lowly ranked. Equally, on the faithfulness constraint IDENT-IO_{DIPH}, MAX-IO_{SEG} and DEP-IO(V) which forbid feature change, deletion and insertion are appropriate constraints and they will be ranked as shown in tableau (4.33). *CODA, *DIPH, *[REDUCED-V] >> MAX-IO_{SEG} >> IDENT-IO_{DIPH}, DEP-IO(V) >> ONSET

(4.33) /'eɪ.kə/ → [ɛ.ɛ.ka] 'acre'

/'eɪkə/	*CODA	*DIPH	*[REDUCED-V]	MAX-IO _{SEG}	IDENT-IO _{DIPH}	DEP-IO(V)	ONSET
a. [eɪ.kə]		*!	*				
b. [ɛ.ɛk]	*!				*		*
c. ↵ [ɛ.ɛ.ka]					*	*	**
d. [ɛ.ka.a]				*!	*	*	**

Tableau (4.33) has an English input /'eɪ.kə/ whose first syllable is a diphthong; it does not have an onset. Consequently, there is a repair by introducing a syllable boundary in Ekegusii since diphthongs are not allowed in the language. As a result, candidate (c) is the most harmonic though it violates the low ranked IDENT-IO_{DIPH}, ONSET and DEP-

IO(V) constraints. Conversely, candidate (a) is the most disharmonic. It violates the high ranked constraints of *DIPH, and *[REDUCED-V] which ban diphthongs and the schwa respectively. As for candidate (b), it violates the high ranked *CODA which forbids coda consonants. Lastly, candidate (d) does not fare well either. Though it does not violate any of the undominated markedness constraints, it violates the faithfulness constraints MAX-IO_{SEG} which Ekegusii ranks highly, hence, it does not survive.

4.4.2.2 CV Syllable Structure

The CV structure has an onset consonant, a vowel peak and a null coda. The CV structure was very dominant in Ekegusii. However, this is not unique because it is considered the most unmarked of all the syllable structures (Blevins, 1995). Traditionally, the CV syllable structure can be represented as follows:

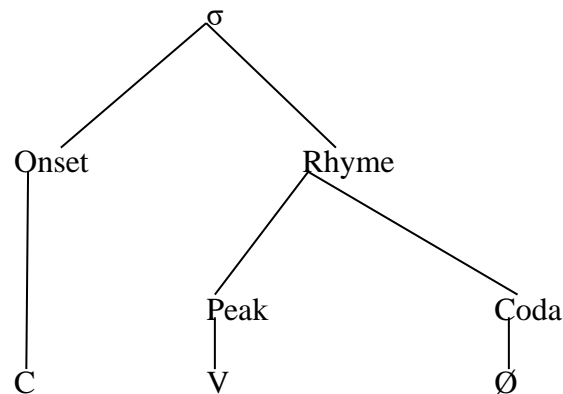

Figure 4.2 CV Syllable Structure

The figure indicates that onset has a consonant, the peak which has a vowel and a null coda. The CV syllable structure was observed in the following borrowed segments.

English Input	Ekegusii Output	English Gloss
/ˈbɑ:θʊm/	[e.βa.tu.ru.mu]	‘bathroom’
/ˈblæŋkɪt/	[o.βo.ra. ^ŋ ge.ti]	‘blanket’
/ˈbeɪsɪn/	[e.βe.se.ni]	‘basin’
/ˈtʃɪmni/	[e.ci.mu.ni]	‘chimney’
/ˈkæptənd/	[e.ka.βa.tɪ]	‘captain’
/ˈkʌmpəni/	[e.ka. ^m ba.nɪ]	‘company’
/kənˈdʌktə/	[e.ko. ⁿ da.yi.ta]	‘conductor’
/ˈtrænsfɜː/	[e.tu.ra. ⁿ si.βa]	‘transfer’
/ˈwaɪə/	[e.wa.ja]	‘wire’

From the data, it can be noted that virtually all the consonants can occupy the onset position. They include: plosives like: /t/, /c/ and /k/, prenasalized stops like /^mb/, /ⁿd/ and /^ŋg/, fricatives like /β/, /s/, /ⁿs/, /ɣ/nasals: /m/ and /n/ as well the trill liquid /r/ and the approximant /w/. Besides, it can be confirmed that the other consonants not manifested in the data occupy the onset position. However, plosives and fricatives are very prevalent. Again, this can be attributed to the fact that plosives and fricatives have low sonority relative to other categories hence, they make better onsets.

As already mentioned, OT tries to account for the CV syllable structure as follows. First, we have the universal markedness constraints which will apply to determine the most harmonic outputs. The *CODA which requires that syllables must not have codas; in the CV structure this constraint is relevant. Secondly, we have ONSET constraint which requires that syllables must have onsets. Unlike the V syllable structure which has onsetless syllables, the CV syllable structure has onset. Therefore, this constraint is relevant and applicable; but it must not be a complex onset. Therefore, depending on the input *CO_{ONS}, *CL_{ONS} and *CN_{ONS} will be the appropriate constraints. Thirdly, is *PEAK-C which dictates that the peak must be filled with a vowel. It forbids consonants from

occupying the peak position. In the CV syllable, the peak is a vowel. Also, from the input, like ‘balcony’ [ˈbælkəni] adapted as [βarikoni] it can be noted that it has sounds not attested in the Ekegusii language. To account for their adaptation, the undominated markedness constraints *[LAT], *[b] and *[REDUCED-V] are proposed. Further, from the outputs it can be noted that they allow feature change, insertion and deletion which violate the faithfulness constraints. Thus, we can invoke DEP-IO(V) and IDENT-IO_{CONT/LAT} as relevant constraints that can evaluate the input. The constraints will be ranked as follows:

*CODA, *PEAK-C, *[b], *[LAT], *[REDUCED-V] >> DEP-IO(V), IDENT-IO_{CONT/LAT}

(4.34) /ˈbælkəni/ → [βa.ri.ko.ni] ‘balcony’

/ˈbælkəni/	*CO DA	*PEA K-C	*[b]	*[LAT]	*[REDU CED-V]	DEP- IO(V)	IDENT- IO _{CONT/LAT}
a. [βa.ri.ko.ni]						*	**
b. [ba.l.ko.ni]		*!	*	*			
c. [βa.ri.kon]	*!						**
d. [bæ.l.kə.ni]	*!		*	*	*		

Candidate (a) is the optimal form since it does not violate any of the markedness constraints ranked highly in the language. However, it violates all the other low ranked faithfulness candidates thus survives minimally. On the other hand, (d) is the most

disharmonic. It violates all the high ranked markedness constraints like *CODA, *[b], *[LAT] and *[REDUCED-V] except *PEAK-C. Equally, candidate (b) does not do well either. It violates the *PEAK-C, *[b], and *[REDUCED-V] constraints hence, it is eliminated. Candidate (c) is less harmonic than the winning candidate. It violates the high ranked *CODA constraints; consequently, it is eliminated. From the evaluation, we can note that the *CODA, *PEAK-C, *[b], *[LAT] and *[REDUCED-V] constraints dominate all the faithfulness constraints which are not crucially ranked.

4.4.2.3 CGV Syllable Structure

The CGV structure has an onset consonant, followed by a glide then a vowel and finally a null coda. The CGV structure is not very dominant in Ekegusii. Its structure can be represented as:

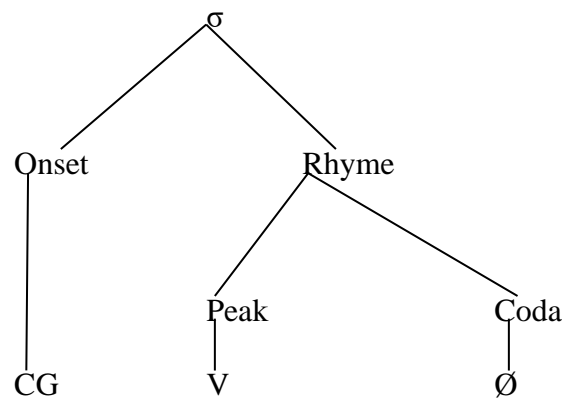

Figure 4.3 CGV Syllable Structure

The figure indicates that onset has two consonants, the peak which has a vowel and a null coda. The CGV syllable structure was observed in only three loanwords:

English Input	Ekegusii Output	English Gloss
/swɪtʃ/	[e.swi.ci]	‘switch’
/ˈswetə/	[e.swe.ˀta]	‘sweater’

/kəm'pju:tə/ [e.ko.^mbju.ta] 'computer'

Ekegusii forbids consonant clusters. Where we have pre-nasalized stops typical of Bantu languages, these are considered single articulations and not clusters. It can be noted that the CGV syllable structure which occurs in Ekegusii is very restrictive. This means that not all consonants will combine to form the CGV in Ekegusii. Predictably, it is a consonant, followed by a glide then a vowel. Scholars have argued that in cases where languages allow clusters, there are restrictions on the type of sound to occur and the sequence with which they follow each other (Blevins, 1995; Morelli, 2003). Besides, languages that allow the formation of onsets and codas show striking similarities (Ladefoged & Johnson, 2011). For instance, consonants in languages will prefer to form longer legitimate complex onsets than codas. The principle responsible for maximizing the onset is the Maximum Onset Principle (MOP) (Kahn, 1976).

The restriction that Ekegusii places on the CGV syllable structure is not unique. In fact, in most languages it can be predicted that the second consonant in the onset is glide like [w, j] while the first consonants could most likely be plosives or fricatives (Ladefoged & Johnson, 2011). What regulates this combination is the Sonority Sequencing Principle which states that a syllable sonority increases from the beginning of the syllable onwards and decreases from the beginning of the peak onwards. So, phonemes can be profiled according to how sonorous they are in relation to others. Sonority increases downwards as shown.

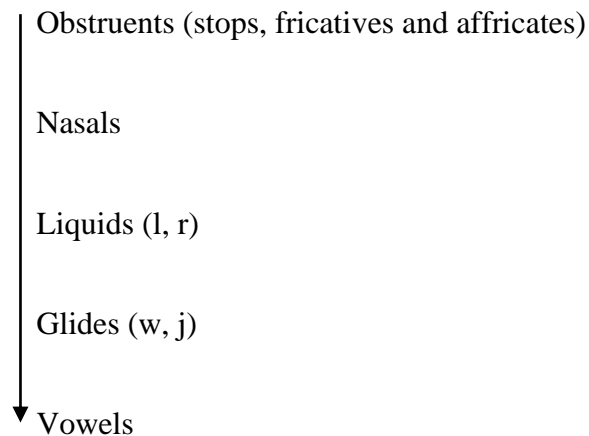

Any onset that reverses the direction of increasing sonority like [*mk] and [*rb] or decreasing sonority from peak [*lj] and [*km] are disallowed.

In a nutshell, we can note that Ekegusii adheres to this sonority sequencing principle, although very few loanwords manifested the glides [w, j]. We can account for this CGV syllable structure in Ekegusii using OT's constraints. It appears the overriding constraint is the fact that an onset is formed by consonant followed by a glide. We propose *CG which can be incorporated in the universal markedness constraints, together with the *CODA which is undominated. Also relevant is the Sonority Sequencing Principle which Ekegusii adheres to hence, we can propose a markedness constraint *SSP to evaluate the outputs further. Thus, from a loanword like 'switch' /swɪtʃ/ which is adapted as [e.swi.ci], other faithfulness constraints which are proposed to evaluate the candidates further include, DEP-IO(V) which forbids insertion and MAX-IO_{SEG} which militates against deletion. Therefore, these constraints will interact to determine the most acceptable forms and the constraints will be ranked as:

*CODA, *SSP >> MAX-IO_{SEG} >> DEP-IO(V), *CG

(4.35a) /swɪf/ → [e.swi.ci] ‘switch’

/swɪf/	*CODA	*SSP	MAX-IO _{SEG}	DEP-IO(V)	*CG
a.  [e.swi.ci]				*	
b. [swɪf]	*!				
c. [e.wsi.ci]		*!		*	*
d. [e.si.ci]			*!	*	

Candidate (a) is the most harmonic. It only violates the faithfulness constraints DEP-IO(V) which forbids insertion, surviving optimally because markedness constraints are ranked higher than the faithfulness constraints in this case. As for (b), it violates the high ranked undominated *CODA constraint, as a result, it does not survive. Candidate (c) reverses the sonority sequence which Ekegusii ranks high besides violating the faithfulness constraints; DEP-IO(V), thus it is eliminated. Candidate (d) does not do well either. Although it does not violate any of the high ranked markedness constraints like *CODA and *SSP, it violates MAX-IO_{SEG} which Ekegusii ranks above other faithfulness constraints. Thus, it is also eliminated out.

Another example we can refer to is the loanword /kəm'pju:tə/ ‘computer’ which is mapped as [e.ko.^mbju.ta] in Ekegusii. With the presence of the glide /j/ there is direct mapping. However, other markedness constraints apply so as to evaluate the input. They include: *CODA which forbids consonants at the coda and in the absence of a schwa the undominated *[REDUCED-V] is also relevant to prohibit its occurrence.

Further, Ekegusii prohibits post nasal devoicing; therefore, *NÇ is another markedness constraint that is relevant. The output violates a number of faithfulness constraints which include: IDENT-IO_{NAS/VOI/LONG} and DEP-IO(V). The constraints will dominate each other as follows:

*[REDUCED-V], *CODA >> IDENT-IO_{NAS/VOI/LONG}, DEP-IO(V)

(4.35b) /kəm'pju:tə/ → [e.ko.^mbju.ta] 'computer'

/kəm'pju:tə/	*[REDUCED-V]	*CODA	*NÇ	IDENT-IO _{NAS/VOI/LONG}	DEP-IO(V)
a. [e.ko. ^m bju.ta]				***	
b. [kəm.pju:.tə]	*!*	*	*		
c. [e.ko. ^m bɪ.u.tə]	*!			***	*
d. [e.ko.pju.ta]			*!		

In tableau (4.35b), it is indicated clearly that Ekegusii language pays more attention to structural well formedness of the loanwords than faithfulness of the output to input. Thus, candidate (a) is the most harmonic; it does not violate the high ranked markedness constraints like allowing the occurrence of the schwa, coda consonants and post nasal devoicing. On the other hand, (b) is the most disharmonic. It violates all the high ranked undominated constraints which are *[REDUCED-V] and the *CODA which ban codas and the schwa as well as *NÇ which prohibit post nasal devoicing in the Ekegusii. Consequently, it is eliminated. Candidate (c) and (d) are eliminated because each of them violates *[REDUCED-V] and *NÇ respectively which are ranked highly in the Ekegusii language. Besides, they also violate the low ranked faithfulness

constraints limiting their chances of surviving. The CGV syllable structure restricts the way borrowing occurs in Ekegusii in that it governs the cluster consonants that are allowed in the language. Unlike English which is elaborate in the cluster consonants by allowing various combination, the CGV Ekegusii syllable structure dictates that whatever is adapted must be a consonant followed by a glide specifically /w/ or /j/ then a vowel. Any other illegal structure is repaired accordingly so as to be in line with the language's phonotactics.

The findings on the syllable structures allowed in Ekegusii are very similar to Ndambuki (2013). He finds that Kikamba has open syllables and does not allow consonant clusters. Both Ekegusii and Kamba are Bantu languages which explains the syllable similarity. Similarly, Harb (2014) notes that in the Hawaiian syllable structure, onset is optional and if it occurs maximally one consonant is allowed, initial consonant clusters are prohibited, nucleus is obligatory (either short or long) and codas are strictly prohibited. Harb establishes that markedness constraints override faithfulness in Hawaiian. Whereas this was also established in Ekegusii, there was a slight deviation on the V type of syllable where faithfulness constraints dominate some markedness constraints.

Similarly, Aljumah (2008) study on the syllable structure of Al-Ahsa a dialect of Arabic, deviated from the findings of this study in that Al-Ahsa unlike Ekegusii prohibits initial consonant clusters but allows complex codas which are analysed as dominated by moras. Further findings which were dissimilar are those by Btoosh (2006)

on the Jordanian Karak Arabic which allows opacity in word final, adheres to complex codas, non-geminate complex codas and has an ultra-heavy syllable.

Conclusively, we can note that languages differ considerably in the syllable structures that they permit. Whereas some will allow complex onsets and codas like English, others will disallow them like Ekegusii, Kamba and Hawaiian. In instances where clusters are allowed, like the case of Ekegusii, it is highly restrictive on what can occur and in which order. Permissible syllable structures in a language to a large extent determine a language's phonotactics which constrain borrowing as it has been observed in Ekegusii.

Lastly, on these phonological adaptations, we can observe that OT did effectively account for the objectives that the research sought to meet under the phonological adaptations. In, the first objective, the underlying phonological adaptations of borrowed sounds were analysed for both vowels and consonants. OT's constraints were used to account for segments that are permissible in Ekegusii and those ones which are not. Consequently, in an attempt to substitute segments not in the Ekegusii inventory, various phonological processes were employed. These too were accounted for using OT's constraints. Also, Ekegusii phonotactics that constrain borrowing were looked into, both at the segmental level and syllabic level. These too were accounted for using OT's universal markedness and faithfulness constraints.

4.5 Chapter Summary

This chapter has discussed the phonological adaptations of borrowed sounds (vowels and consonants). It has presented how different sound segments are mapped from English to Ekegusii with the language selecting those that are unmarked and cross-linguistically preferred. Secondly, phonological processes that shape the patterns of the borrowed segments in Ekegusii are discussed and how OT constrains their occurrence. Lastly, the phonotactics of the Ekegusii language that constrain borrowing are proposed and discussed.

CHAPTER FIVE

**MORPHOLOGICAL ADAPTATIONS AND MORPHOTACTICS IN
BORROWED SEGMENTS**

5.0 Introduction

The same way loanwords are integrated to the phonology of a particular language, they can also be integrated to the morphology of a language. In this case, loanwords undergo modification of the morphological structure to achieve harmony with the established predominant patterns and morphological systems of the borrowing language. Ideally, when a borrowed word enters a certain word class in a recipient language, it theoretically, acquires all features of that word class (Pakerys, 2016). Besides the phonological adaptations that the loanwords undergo in Ekegusii, this section discusses the morphological conditioning. This chapter presents first, the noun morphology of Ekegusii, secondly, the morphological class adaptations, then inflectional and derivational morphology of loanwords and lastly morphological processes as well as how each is constrained by OT's markedness and faithfulness constraints

5.1 Ekegusii Noun Morphology

Literature on Bantu languages indicates that nouns are classified into sets which are labelled noun classes and at least 22 classes have been identified (Welmers, 1973). Individual cognate languages have this number or less. Ekegusii which is a Bantu language has 21 noun classes (Cammenga, 2002). The classes are presented as follows:

Class	Example (Singular/Plural)	English Gloss
1. o-mo-	o-mo-nto	'a person'

1b. Ø	tata	‘father’
2. a-βa-	a-βa-nto	‘people’
3. o-mo-	o-mo-te	‘a tree’
4. e-me-	e-me-te	‘tress’
5. e-ri-	e-ri-so	‘an eye’
6. a-ma-	a-ma-iso	‘eyes’
7. e-ke	e-ke-reβi	‘head scarf’
8. e-βi-	e-βi-reβi	‘head scarfs’
9. e-	e-kaβira	‘tribe’
9a. e-n	e-niyo	‘kidney’
10. ci-	ci-kaβira	‘tribes’
10a. ci-n	ci-niyo	‘kidneys’
11. o-ro-	o-ro-ko	‘firewood’
12. a-ka-	a-ka-mura	‘small boy’
14. o-βo-	o-βo-βa	‘mushroom’
15. o-ko-	o-ko-βoko	‘hand’
16a. a-	a-se	‘place’
21. ná-	naŋera	‘a black cow’

(Cammenga, 2002)

Typically, from the Ekegusii noun classes in terms of structure, it can be inferred that the noun has two elements, a prefix and a root. The prefix in most of the classes consists of an initial vowel called an augment or pre-prefix which consists of a consonant and a vowel. The underlying representation of this full prefix is thus, /V-CV-/. However, personal names are regularly non-augmented whether or not they are used to address someone directly (Cammenga, 2002). Katamba (2003) notes that nouns are assigned to different classes, often on a minimally semantic basis, depending on whether they refer

to a human/animate individual or on the basis of salient properties of the entity denoted by a noun such as its shape and size.

A closer look at the Ekegusii noun classification reveals that class 1 and 2 prefixes select nouns which denote human referents in singular and plural respectively. Class 3 and 4 select sociocultural objects, events or periods, trees and parts of the body. Class 5 and 6 on the other hand, has tools, parts of fruits and locations. Class 7 and 8 has inanimate referents, parts of the body, some animals and place names. Class 9 and 10 denote most animal referents. Class 12 has the diminutive while class 14 comprises of some body parts, objects and crop names. Class 15 has abstract nouns while 16 refers to a place and lastly 21 has proper nouns or proper names of persons. From this noun classification, a number of inferences can be made. First, some human categories occur outside the expected human classes 1 and 2. This is class 12 which denotes the diminutive form ‘*aka-*’. Secondly, the noun prefix carries information about number and shape. Thirdly, the prefix plays no role in determining the noun class, instead the nature of the noun whether it is animate or inanimate determines class assignment. On the other hand, researchers in Bantu languages agree that the noun class features are determined by grammatical number, semantics, (whether they are human/animal/non-living things) and in other cases it is arbitrarily assigned (Katamba, 2003).

5.2 Morphological Class Adaptations

Morphological adaptation includes all aspects of derivational and inflectional integration (Mangrio, 2016). Specifically, we examine the mapping of English

loanwords to Ekegusii noun classes, inflectional and derivational affixation to the loanwords, morphological processes attested in the loanwords and how they are all constrained by Ekegusii's morphotactics.

As already observed, Ekegusii has 21 noun classes. How are the loanwords integrated to these classes? The data below shows how loans are integrated to the various classes.

Class 3 and 4

Ekegusii Loan (3)	Plural (4)	English Gross
o-mo-ito	e-me-ito	'mattress'

Class 7 and 8

Ekegusii Loan (7)	Plural (8)	English Gross
e-ke.rasi	e-βi-rasi	'glass'
e-ki-riniki	e-βi-riniki	'clinic'
e-ke-si	e-βi-kesi	'case'
e-ke-rayita	e-βi-rayita	'tractor'

Class 9 and 10

Ekegusii Loan (9)	Plural (10)	English Gross
e-seneta	ci-seneta	'senator'
e-roja	ci-roja	'lawyer'
e-sekeretari	ci-sekeretari	'secretary'
e-yaβana	ci-yaβana	'governor'
e-sati	ci-sati	'shirt'
e-tiβi	ci-tiβi	'T.V'
e-roni	ci-roni	'loan'
e-soβa	ci-soβa	'sofa'
e-rura	ci-rura	'ruler'

Class 14

Ekegusii Loan	Plural	English Gross
oβo-rangeti	ama-rangeti	'blanket'

Data from the loanwords in Ekegusii indicates that class 3 and 4, 7 and 8 as well as class 14 comprise of inanimate referents. However, class 9 and 10 is a mixture of both human referents like lawyer, senator, governor and inanimate referents like loan. None of the loanwords especially human referents was mapped to class 1 and 2. This loanword adaptation indicates that the overriding factor seems to be the prefix marker whereby if the beginning of the loanword adaptation matches the Ekegusii prefix, the loan is assigned to that class. These findings are very similar to those established in Sesotho, a Bantu language whereby if the beginning of a loanword matches a Sesotho class marker, the noun is loaned into that class and if the beginning of the loanword is not similar to a Sesotho class marker, it is loaned in with no overt class marker (Tonks & Demuth, 2002).

Class assignment and mapping of the loanwords in Ekegusii can be accounted for using OT's morphological constraints. First, we note that languages may require words to begin with vowels and end with vowels, although syllables may not be under such obligations. Such is the case in Ekegusii borrowing whereby every loanword takes a morphological vowel which is an augmented prefix also called a pre-prefix, yet the language allows CV syllable. Ekegusii imposes a morphotactic that requires loanwords to be aligned with the morphological affix. In this case, GA comes in handy since it not only allows for independent constraints on the edges of syllables but also on higher prosodic units like words to be accounted for. McCarthy and Prince (1993a) use Generalized Alignment theory constraints to show how morphological and prosodic

edges interact with each other: they propose the constraint ALIGN (Affix, L, Stem, L) which means that the left edge of the affix must coincide with the left edge of some stem; in other words, it expresses an instance where there is a prefix rather than a suffix. Since most of the loanwords add prefixes in adaptation rather than suffixes, for Ekegusii we propose the morphotactic constraint ALIGN ([e]_{AF}, L, Stem, L) which states that the left edge of the prefix [e] must align with the left edge of the stem. This markedness constraint is simplified as ALIGN-[e]. The violation of this morphotactic constraint is realized in terms of distance from the designated edge, in other words the extent of violation is determined by the string of segments separating the left edge of [e-] from the left edge of the stem. In terms of representation, the left edge of the stem is indicated by ‘[’’. Secondly, is the constraint ALIGN (PrWd, L, Stem, L) which requires that each left edge of prosodic word aligns with the left edge of some stem. When representing the edges of a morphological word we use ‘{’ for the left edge while ‘}’ is used for the right edge.

McCarthy and Prince (1993a) further argue that some prosodic constraint, like NO-CODA, must dominate some morphological constraint, like Align (Affix, Stem) for morphology to be prosodic at all within OT. In other words, phonological constraint must dominate some constraint of the morphology. Hence in Ekegusii, the constraint hierarchy will be NO-CODA >> ALIGN([e]_{AF}, L, Stem, L) >> ALIGN (PrWd, L, Stem, L). ONSET is also another prosodic constraint although it will be dominated since loanwords in Ekegusii take an initial morpheme class marker. In addition, the inputs from the English language are observed to undergo suffixation but when adapted they

are prefixed. Therefore, the constraint: ALIGN (PrWd, R, Stem, R) which requires that each right edge of prosodic word aligns with the right edge of some stem is relevant although it will be dominated whenever invoked. So far, the constraints proposed are all markedness constraints which are always counterbalanced by faithfulness constraints. To evaluate the outputs further DEP-IO(V) which militate against vowel insertion, MAX-IO_{SEG} which disallows segment deletion as well as IDENT-IO(F) which prohibits feature change will be invoked.

Using GA's markedness constraints and OT's markedness and faithfulness constraints, we can account for class assignment and mapping of the loanwords in Ekegusii. First, we illustrate in tableau (5.1) using an example from class 9/10 where most of the borrowed words were mapped to. So, the constraints will be ranked as follows:

*CODA >> ALIGN-[e] >> ALIGN (PrWd, L, Stem, L) >> ONSET >> DEP-IO(V)

(5.1) senator → {e-seneta}

/senətə/	*CODA	ALIGN-[e]	ALIGN (PrWd, L, Stem, L)	ONSET	DEP-IO(V)
a. $\left[\begin{array}{c} \text{e} \\ \text{se} \\ \text{ne} \\ \text{ta} \end{array} \right]$			*	*	*
b. [se.ne.ta]		*!			
c. [se-e-net]	*!	*		*	
d. [se.nə.tə]		*!			

Tableau (5.1) indicates that candidate (c) is the most disharmonic. It not only violates the high ranked markedness constraints: *CODA but also the ALIGN-[e] constraint that allows for the attaching of a prefix. Besides, it violates the low ranked ONSET; hence, it is discarded. On the other hand, candidates (b) and (d) are isoharmonic. Each violates the higher ranked markedness constraints ALIGN-[e] which require prefix [e] to be attached; therefore, they are eliminated. Candidate (a) is the optimal although it violates the low ranked constraints ALIGN (PrWd, L, Stem, L), ONSET and the faithfulness constraint DEP-IO(V) by inserting the morpheme marker word initial.

Similarly, class 3 /4 allows for the insertion of the morpheme marker although in this case it is 'o'. Thus, the same constraints can be used to account for the loanword mapping in the class and they will be ranked as follows in tableau (5.2):

*CODA >> ALIGN-[e] >> ALIGN (PrWd, L, Stem, L) >> ONSET >> DEP-IO(V)

(5.2) mattress → {omoito}

/mætrəs/	*CODA	ALIGN-[o]	ALIGN (PrWd, L, Stem, L)	ONSET	DEP-IO(V)
a.  [o-mo.i.to]			*	*	**
b. [mo.i.to]		*!		*	*
c. [mo.i.to.o]		*!		**	**
d. [mæ.trəs]	*!	*			

Tableau (5.2) shows that candidate (d) is the most disharmonic. It not only ends with a consonant violating *CODA in the Ekegusii language but also drops the morpheme marker ‘o’ requirement for borrowed words in this class. On the other hand, candidates (b) and (c) equally violate the high ranked markedness constraints ALIGN-[e] in addition to violating the low ranked ONSET and DEP-IO(V) which leads to their elimination. Candidate (a) is the optimal although it violates the low ranked ALIGN (PrWd, L, Stem, L), ONSET and the faithfulness constraints DEP-IO(V) allowing insertion of the morpheme marker word initial.

Class 7 /8 also show the insertion of the morpheme marker ‘e’. Likewise, the same constraints can be used to account for the mapping of loanwords in this class and they will be ranked as: *CODA >> ALIGN-[e] >> ALIGN (PrWd, L, Stem, L) >> IDENT-IO_{LAT/VOI}, DEP-IO(V)

(5.3) glass \longrightarrow {e-kerasi}

/gla:s/	*CODA	ALIGN-(e-)	ALIGN (PrWd, L, Stem, L)	IDENT-IO _{LAT/VOI}	DEP-IO(V)
a.  [e-ke.ra.si]			*	**	***
b. [ke.las]	*!	*		*	*
c. [e.ke.ra.si-e]			*!	**	****
d. [gla:s]	*!	*			

Tableau (5.3) indicates that candidate (b) and (d) are isoharmonic. They each violate the high ranked undominated markedness constraint *CODA and ALIGN-[e] in the Ekegusii language as well as the low ranked faithfulness constraints. Thus, they are eliminated. Conversely, candidates (c) violates the markedness constraint ALIGN (PrWd, L, Stem, L) which requires that the left edge of the prosodic word be aligned with the left edge of the stem, thus it is eliminated. Candidate (a) is the optimal although it violates ALIGN (PrWd, L, Stem, L) which is a markedness constraint which is not ranked highly in Ekegusii besides violating the faithfulness constraint by allowing feature change where one of the segments undergoes devoicing, another changes from a lateral sound to a trill and then the morpheme marker is inserted.

Data from class 14 presented indicates that this class too allows for the insertion of the morpheme marker ‘o’. So, as already proposed the same constraints used in other classes can be used to explain the mapping as follows:

*CODA >> ALIGN-[e] >> ALIGN (PrWd, L, Stem, L) >> ONSET >> IDENT-IO_{NAS/CONT/LAT}, DEP-IO(V)

(5.4) blanket \longrightarrow {oβo-ra^hge.ti}

/blæŋkɪt/	*CODA	ALIGN- GN- [o]	ALIGN (PrWd, L, Stem, L)	ONSET	IDENT- IO _{NAS/CO} NT/LAT	DEP- IO(V)
a. [o.βo.ra. ^h ge.ti]			*	*	***	***
b. [βo-ra. ^h ge.ti]		*!			***	**
c. [βo-o-la. ^h ge.ti]		*!		*	**	***
d. [blæ.ŋkɪt]	*!	*				

Tableau (5.4) indicates that candidate (d) is the most disharmonic. It violates the undominated *CODA since it does not allow the occurrence of the morpheme marker [o], hence, it is eliminated. Candidate (b) and (c) are isoharmonic. Each of them violates the high ranked markedness constraint ALIGN-[o] which requires the output to attach the prefix [o] besides the low ranked markedness constraint ONSET as well as all the faithfulness constraints. Candidate (a) is the optimal although it violates the markedness constraints ALIGN (PrWd, L, Stem, L) and ONSET which Ekegusii ranks lowly in addition to all the faithfulness constraints.

5.3 Inflectional and Derivational Morphology of Loanwords

Inflectional morphology deals with syntactically determined affixation while derivational morphology is used to create new lexical items (Katamba, 2003). However,

Katamba is quick to note that there is no unanimity in the classification of processes as inflectional or derivational. What differentiates the two is like the criterion of obligatoriness which characterises inflection and productivity which characterises derivation. Generally, morphology deals with information about word structure that is relevant to syntax. Therefore, affixes that express number, tense and person fall under inflectional morphology. However, as for nouns, the inherent categories are number and gender. Number is an obligatory category in English nouns in that they must inflect to show whether they are singular or plural. The loanwords from the English language inflect for number and typically, it is suffixed. On the other hand, when they are borrowed to Ekegusii, the loanwords mark number but it is prefixed as shown in the data presented.

English Input Singular	English Output Plural	Ekegusii Output Singular	Ekegusii Output Plural
brake	/breɪk-s/	ebureki	ci-βurekɪ
bathroom	/'ba:θrum-z/	ebaturumu	ci-βaturumu
brush	/brʌʃ-ɪz/	eburasi	ci-βurasi
class	/kla:s-ɪz /	ekerasi	e-βi-rasi
clinic	/'klɪnɪk-s/	ekiriniki	e-βi-riniki
governor	/'gʌvənə-z/	egabana	ci-ɣaβana
blanket	/'blæŋkɪt-s/	oborangeti	a-ma-ra ⁹ geti
machine	/mə'ʃi:n-z/	amasini	a-ma-sini
mattress	/mætrəs-ɪz /	omoito	e-me-ito

Data presented reveals that loans inflect for number. However, the prefix selected is determined by the class the loan had been mapped to in Ekegusii. This can be justified since the prefix that forms the noun structure in Ekegusii carries number. Some of the prefixes that express number include: {ci-, e-βi-, a-ma-, e-me-}. This plural formation in Ekegusii indicates that Ekegusii imposes a morphotactic which demands that

loanwords attach different affixes depending on the class the loanword had been mapped to. The morphotactics we propose here is ALIGN (ci-, e-βi-, a-ma-, e-me-). This phenomenon can be accounted for using GA and OT's constraints. First, we note that most of the loanwords were mapped to Ekegusii class 9 /10 which forms the plural by dropping the morphological class marker 'e' and introducing a prefix (ci-). All the other classes represented in the loanwords: class 3 /4, 7 /8 and 14 retain the initial morphological vowel whether it is 'e-' or 'a-'.

We begin with the plural marking for class 9/10 represented by the prefixes [e-] and [ci] respectively. GA's constraints, ALIGN-[e] and ALIGN (PrWd, L, Stem, L) are invoked. In this category, it will be stated as ALIGN-[ci] which states that the left edge of the prefix [ci] must align with the left edge of the stem while ALIGN (PrWd, L, Stem, L) requires that each left edge of prosodic word aligns with the left edge of some stem. Also relevant is the universal markedness constraint *CODA which bans coda consonants and the faithfulness constraints MAX-IO_{SEG}, IDENT-IO_{CONT/DIPH} and DEP-IO(V) which prohibits deletion, feature change and disallows insertion respectively in the mapping of 'brakes' as {ci-βureki}. The constraints will be ranked as follows:

*CODA >> ALIGN-[ci] >> MAX-IO_{SEG} >> ALIGN (PrWd, L, Stem, L) >> IDENT-IO_{CONT/DIPH}, DEP-IO(V).

(5.5) brakes \longrightarrow {ci-βureki}

/breik-s/	*CODA	ALIGN-[ci]	MAX-IO _{SEG}	ALIGN (PrWd, L, Stem, L)	IDENT-IO _{CONT/DI} PH	DEP-IO(V)
a. {ci-βu.re.ki}				*	**	***
b. {ci-re.ki}			*!	*	*	**
c. [ci-βu.rek]	*!			*	**	**
d. [breik-s]	*!	*				

Tableau (5.5) indicates that candidate (d) is the most disharmonic. It not only ends with a consonant violating the undominated markedness constraint *CODA but it also violates ALIGN-[ci]. Hence, it is eliminated. On the other hand, candidate (b) violates the high ranked faithfulness constraints MAX-IO_{SEG} which disallows deletion. Though a faithfulness constraint, Ekegusii ranks it higher than the markedness constraint ALIGN (PrWd, L, Stem, L) and other faithfulness constraints. Candidate (c) does not fare well either. It violates the higher ranked undominated *CODA constraint which forbids coda consonants. Candidate (a) is the optimal form although it violates the markedness constraint ALIGN (PrWd, L, Stem, L) and both the faithfulness constraints by allowing feature change as well as vowel insertion. It wins optimally but not perfectly.

For class 3 /4, represented by the prefixes [o-mo] and [e-me], the plural formation is formed when the pre-prefix ‘o’ followed by ‘mo’ changes to ‘e’ followed by ‘me’, so that it is {e-me-}. To explain this plural formation, we invoke both OT’s markedness constraints *CODA, which bans consonant at the coda and GA’s ALIGN-[e-me] which demands that the left edge of the prefix [e-me] must align with the left edge of the stem as well as ALIGN (PrWd, L, Stem, L) which requires that each left edge of prosodic word aligns with the left edge of some stem. Another relevant markedness constraint is ONSET which demands that syllables have onsets. All these proposed constraints are markedness constraints which are always counterbalanced by faithfulness constraints. In this regard, the input and output mapping of ‘mattresses’ as {e-meito}, is observed to violate DEP-IO(V) by allowing insertion and feature change; IDENT-IO_{VOI}. So, the constraints will be ranked as follows:

*CODA >> ALIGN-[e-me] >>ALIGN (PrWd, L, Stem, L) >> ONSET >> DEP-IO(V),
IDENT-IO_{VOI}

(5.6) mattresses \longrightarrow {e-meito}

/mætrəs-ɪz/	*CODA	ALIGN-[e-me]	ALIGN (PrWd, L, Stem, L)	ONSET	DEP-IO(V)	IDENT-IO _{VOI}
a. $\left[\begin{array}{c} \text{e} \\ \text{me} \end{array} \right] \text{i.to}$			*	**	*	*
b. [me.i.to]		*!		*		*
c. [e-me.it]	*!		*	*		*
d. [mæ.trəs-ɪz]	*!*	*				

Candidate (d) is the most disharmonic. It violates all the high ranked markedness constraints: *CODA and ALIGN-[e-me] which Ekegusii language ranks highly, thus, it is eliminated. Conversely, candidate (a) is the most harmonic though it violates the markedness constraint ALIGN (PrWd, L, Stem, L), ONSET and the low ranked faithfulness constraint DEP-IO(V) which forbids vowel insertion and IDENT-IO_{VOT} which forbids feature change. For candidate (b), it violates the high ranked markedness constraint ALIGN-[e] which Ekegusii ranks highly rendering it unfit. Lastly, candidate (c) violates the undominated *CODA which eliminates it from competition. Markedness constraints that demand structural well-formedness dominate the faithfulness constraints that demand similarity between input and output mapping.

As already noted, the nouns in class 7/8 inflect for number by adding the double prefix {e-βi-} to the stem to mark plural. Similarly, GA's and OT's universal markedness and faithfulness constraints can be invoked in this instance to explain this plural formation. First, is the undominated *CODA, constraint which prohibit consonants at the coda position and *CL_{ONS} which forbids a cluster consonant, then ALIGN-[e-βi] which states that the left edge of the prefix [e-βi] must align with the left edge of the stem and ALIGN (PrWd, L, Stem, L) which demands that each left edge of prosodic word aligns with the left edge of some stem. As for the faithfulness constraints DEP-IO (V) which prohibit vowel insertion and MAX-IO_{SEG} which disallows segment deletion are relevant in evaluating the input and output; 'clinics' adapted as {e-βi-riniki}. It can also be observed that the output changes features; therefore, IDENT-IO_{LAT} which forbids feature change is relevant. So, the constraints will be ranked as follows in tableau 5.7:

*CODA, *CL_{ONS} >> ALIGN-[e-βi], >> ALIGN (PrWd, L, Stem, L) >> MAX-IO_{SEG},
IDENT-IO_{LAT}, DEP-IO(V)

(5.7) clinics → {e-βi-riniki}

/'kɫɪnɪk-s/	*CODA	*CL _{ONS}	ALIGN-[e-βi]	ALIGN (PrWd, L, Stem, L)	MAX-IO _{SEG}	IDENT-IO _{LAT}	DEP-IO(V)
a.  [e-βi-rɪnɪkɪ]				*	*	*	***
b. [ɫɪnɪkɪ]			*!		*		*
c. [e-βi-kɾɪnɪkɪ]		*!		*		*	***
d. [kɫɪnɪk-s]	*!	*	*				

Tableau (5.7) indicates that candidate (a) is the optimal form although it violates the markedness constraint ALIGN (PrWd, L, Stem, L) and all the faithfulness constraints by allowing deletion of segments, feature change whereby the lateral is adapted as trill and as vowel insertion. It wins optimally. On the other hand, candidate (d) is the most disharmonic. It violates all the markedness constraints which include the undominated *CODA, *CL_{ONS} and ALIGN-[eβi], hence, it is eliminated. Candidates (b) also violates one of the high ranked markedness constraints: ALIGN-[eβi] which demand attachment of a prefix thus, it does not survive. As for candidate (c) it violates the undominated *CL_{ONS} that forbids cluster consonants in this case a consonant and a liquid. The markedness constraints crucially dominate the faithfulness constraints.

Lastly on number is class 14, borrowed segments which fall in this class mark the plural by prefixing, the pre-prefix {a-ma} to the stem. A case in point is the adaptation of ‘blankets’ as {a-ma-ra^ɓgeti}. GA and OT’s markedness constraints proposed here include the undominated *CODA constraint which disallow coda consonants and *CLONS which forbid cluster consonants and ALIGN-[a-ma] and ALIGN (PrWd, L, Stem, L) which require alignment of prefix and prosodic word respectively. As for the faithfulness constraints, those relevant include MAX-IO_{SEG} for anti-deletion, feature change: IDENT-IO_{NAS/LAT/VOI} and DEP-IO(V) which disallows insertion. They will be ranked as follows in tableau 5.8.

*CODA, *CLONS >> ALIGN-[a-ma] >> ALIGN (PrWd, L, Stem, L) >> MAX-IO_{SEG}
>> IDENT-IO_{NAS/LAT/VOI}, DEP-IO(V)

(5.8) blankets → {a-ma-ra^ɓgeti}

/blæŋkit-s/	*CODA	*CLONS	ALIGN N- [ama]	ALIGN (PrWd, L, Stem, L)	MAX - IO _{SEG}	IDENT- IO _{NAS/LAT/VOI}	DEP- IO(V)
a. [a-ma-ra ^ɓ ge.ti]				*	*	***	***
b. [a-ma-bla ^ɓ ge.ti]		*!		*		**	***
c. [a-ma-ra ^ɓ get]	*!			*	*	***	**
d. [blæ.ŋkit-s]	*!	*	*				

Tableau (5.8) shows that candidate (d) is the most disharmonic. It violates all the high ranked markedness constraints; *CODA, *CLONS and ALIGN-[a-ma]; hence, it is eliminated. On the other hand, candidate (a) is the most harmonic, it satisfies the high ranked markedness constraints and emerges as the winner although it minimally violates the markedness constraint ALIGN (PrWd, L, Stem, L) which is ranked low and all the faithfulness constraints; MAX-IO_{SEG}, IDENT-IO_{NAS/LAT/VOI} and DEP-IO(V). As for candidates (b), it violates one of the high ranked markedness constraint; *CLONS thus, it is eliminated. Candidate (c) is almost optimal; however, it violates *CODA which forbids consonants at the coda. The universal markedness constraints dominate faithfulness constraints.

Another category that nouns inflect for is gender. Katamba (2003) notes that in many European languages, nouns referring to animate individuals are usually either masculine or feminine depending on whether the individual in question is a male or a female. He also notes that in many sub-Saharan African languages, Australian languages and native American languages, this classification does not have even the most tenuous gender basis. In fact, even the English language does not inflect for gender like French. Instead, individual nouns which denote male or female inflect for agreement in syntactic configurations. Similarly, Ekegusii loanwords do not inflect for gender. Instead, they inflect for number and it is determined by the class they belong to.

English Input	Ekegusii Output
Watchman	e-wocimani
Headmaster	e-tumasita

Headmistress e-timisituresi

Chairman e-ceamani

From the data presented it can be inferred that, loanwords borrowed to Ekegusii language which bear gender which in this case refers either to male or female do not inflect for gender. Ekegusii does not have an overt prefix or suffix to mark gender.

OT and GA can account for this mapping by invoking the markedness and faithfulness constraints. In this case we can illustrate using ‘chairman’ adapted as {e-ceamani}. The relevant markedness constraints include: the undominated *CODA constraint which forbids coda consonants, *[REDUCED-V] which bans a schwa and *DIPH which prohibits diphthongs in Ekegusii. Others are ALIGN-[e] and ALIGN (PrWd, L, Stem, L) which demand that the left edge of the prefix [e] must align with the left edge of the stem and the left edge of prosodic word aligns with the left edge of some stem respectively. For the faithfulness constraints DEP-IO (V) which prohibit vowel insertion and MAX-IO_{SEG} which disallows segment deletion as well as IDENT-IO_{DIPH} which disallows feature change can be invoked. The constraints will be ranked as follows in tableau 5.9:

*CODA, *[REDUCED-V], *DIPH >> ALIGN-[e] >> ALIGN (PrWd, L, Stem, L) >>
DEP-IO(V), IDENT-IO_{DIPH}

(5.9) chairman → {e-ceamani}

/tʃeəmən/	*CODA	*[REDUCED-V]	*DIPH	ALIGN N-[e]	ALIGN (PrWd, L, Stem, L)	DEP-IO(V)	IDENT-IO _{DIPH}
a. [e.ce.a.ma.nɪ]					*	***	*
b. [ce.a.ma.nɪ]				*!		**	*
c. [e.ce.man]	*!				*	*	*
d. [tʃeə.mən]	*!	*	*	*			

Candidate (a) is the optimal form although it violates the low ranked markedness constraint ALIGN (PrWd, L, Stem, L) and the low ranked faithfulness constraint by allowing insertion of vowels and feature change. On the other hand, candidate (d) is the most disharmonic. It violates all the markedness constraints which include the undominated *CODA, *[REDUCED-V] and *DIPH as well as the markedness constraints ALIGN-[e] which demand alignment of the prefix. Hence, it is thrown out. As for candidates (b), it violates the high ranked markedness constraint which govern alignment of the prefix; ALIGN-[e] hence, it is eliminated. Lastly, candidate (c) violates the high ranked markedness constraint *CODA as well as ALIGN (PrWd, L, Stem, L), thus, it is eliminated. In this adaptation, universal markedness constraints dominate the faithfulness constraints.

Derivational morphology as already noted creates new words and it is uniquely productive. Ordinarily then, it is expected to generate new words from the borrowed segments. However, the data collected coupled with native speaker competence revealed, that there was very minimal derivation. This is not a unique phenomenon. Hafez (1996) observes that newly introduced loan verbs and nouns have a very limited derivational paradigm. This however does not mean derivation does not occur in Ekegusii nouns. Native Ekegusii nouns are derived to form new classes which include verbs. Data collected revealed only one instance of derivation.

This derivation in Ekegusii is illustrated using the noun /'bæptɪzm/ which is adapted as a [eβatɪsɔ] 'baptism'. A verb can be derived from baptism which is /bæp'taɪz/ adapted [βatɪsɔ] 'baptize'. The input here will be /'bæptɪzm/ (noun) while the output will be [βatɪsɔ] (verb). OT's markedness and faithfulness constraints can be invoked to account for this adaptation. We invoke *CODA, which militates against coda consonants and *CN, which prohibits clusters consonants (consonant and a nasal). Further, it can be noted that both the voiced and voiceless bilabial plosives are not attested in the Ekegusii language. Hence, the markedness constraints *[p] and *[b] are relevant. Also *OBSVOI is relevant because Ekegusii devoices obstruents besides *ALIGN-[e] >> ALIGN (PrWd, L, Stem, L) which are however dominated since this is a case of derivation whereby a verb is derived from a noun. These markedness constraints will be counterbalanced by the faithfulness constraints: DEP-IO(V); which prohibits insertion, MAX-IO_{SEG}; which disallows deletion and IDENT-IO_{VOI/CONT}; which forbids feature change.

as shown in tableau (5.10)

*CODA, *CN, *[p], *[b] >> *OBSVOI >> *ALIGN-[e] >> ALIGN (PrWd, L, Stem, L)

>> MAX-IO_{SEG}

(5.10) /'bæptɪzm / → {βatɪsa} 'baptize'

/'bæptɪzm /	*CO DA	*CN	*[p]	*[b]	*OBS VOI	*AL IGN -[e]	ALIGN (PrWd, L, Stem, L)	MA X- IO _s EG	DE P- IO(V)	IDEN T- IO _{VOI} / CONT
a. [βa.tɪ.sa]						*		*	*	**
b. [bæp.tɪzm]	*!	*	*	*	*	*				
c. [ba.tɪ.sa-e]			*!			*				**
d. [e.βa.tɪ.zo]					*!		*			**

Tableau (5.10) indicates that candidate (b) is the most disharmonic. It violates all the high ranked markedness constraints: *CODA, *CN, *[p], *[b] and *OBSVOI as well *ALIGN-[e]. On the other hand, candidate (a) is the optimal although it violates *ALIGN-[e] since this is a case of derivation and other faithfulness constraint MAX-IO_{SEG}, DEP-IO(V) and IDENT-IO_{VOI}/CONT. Candidate (d) is eliminated on the account that it violates the high ranked markedness constraint; *OBSVOI which Ekegusii attaches importance to. As for candidate (c), it allows the occurrence of a bilabial plosive which is not attested in the Ekegusii language. Universal markedness constraints

dominate the faithfulness constraints in this derivation of a verb from a noun in Ekegusii.

5.4 Morphological Processes

Generative morphology accounts for the different processes of forming words. Some of these processes responsible for word formation include: pre-fixation, suffixation, compounding, conversion, backformation, clipping, blending, acronyms, gliding and reduplication. Out of these word processes clipping, pre-prefixation and gliding were attested in Ekegusii borrowing.

Pre-prefixation is a morphological process where Ekegusii attaches a double prefix to a loanword. Cammenga (2002) refers to this as ‘full’ Gusii prefix property that comprises of an augmented prefix or an initial vowel with a prefix proper. Pre-prefixation was observed in the following loanwords.

Class 3 and 4

Ekegusii Loan (3)	Plural (4)	English Gross
o-mo-ito	e-me-ito	‘mattress’

Class 7 and 8

Ekegusii Loan (7)	Plural (8)	English Gross
e-ke.rasi	e-βi-rasi	‘glass’
e-ki-riniki	e-βi-riniki	‘clinic’
e-ke-si	e-βi-kesi	‘case’
e-ke-rayita	e-βi-rayita	‘tractor’

Class 14

Ekegusii Loan	Plural	English Gross
----------------------	---------------	----------------------

o-βo-rangeti ama-rangeti ‘blanket’

Pre-prefixation in Ekegusii can be accounted for using GA and OT’s markedness and faithfulness constraints. If we illustrate using the English input ‘tractor’ parsed {e-ke-rayita}, the pre-prefix [e] is attached before the prefix proper [ke]. OT’s constraints which can evaluate the input in this case include; the undominated *CODA constraint which forbids coda consonants, *[REDUCED-V] which bans a schwa and *CO_{ONS} which disallows complex onsets. GA’s markedness constraints are ALIGN-[e] and ALIGN (PrWd, L, Stem, L) which demand that the left edge of the prefix [e] must align with the left edge of the stem and the left edge of prosodic word aligns with the left edge of some stem respectively. For the faithfulness constraints DEP-IO (V) which prohibits vowel insertion and IDENT-IO_{CONT} which disallows feature change can be invoked. The constraints will be ranked as follows in tableau 5.11

*CODA, *[REDUCED-V], *CO_{ONS} >> ALIGN-[e] >> ALIGN (PrWd, L, Stem, L)
>> DEP-IO(V), IDENT-IO_{CONT}

(5.11) /'træktə/ → {e-ke-rayita} 'tractor'

/'træktə/	*CO DA	*[REDU VED-V]	*CO ONS	*ALIG N-[e]	ALIGN (PrWd, L, Stem, L)	DEP- IO(V)	IDENT- IO _{CONT}
a. [e-ke-rayita]					*	***	*
b. /'træktə/		*!	*	*			
c. [e-tra-yita]			*!		*	**	*
d. [e-ke-rayit]	*!				*	**	*

Tableau (5.11) indicates that candidate (b) is the most disharmonic. It violates all the high ranked markedness constraints: *CODA, *[REDUCED-V], *CO_{ONS}, and ALIGN-[e]. On the other hand, candidate (a) is the optimal although it violates all the *ALIGN [PrWd, L, Stem, L] and all the faithfulness constraints; DEP-IO(V) and IDENT-IO_{CONT}. Candidates (c) and (d) are isoharmonic. They each violate one of the markedness constraints that Ekegusii ranks highly. These are *CO_{ONS} which disallows complex onsets and *CODA which forbids coda consonants besides violating the faithfulness constraints. Therefore, both are eliminated

Another morphological process observed was clipping. This is the cutting short of a word, either at the beginning or at the end of a word without changing the meaning. It was observed in the following loanwords:

English Input Clipping	Ekegusii O/P before Clipping	Ekegusii O/P after
a. bathroom	e-βaturumu	[eβaβu]
b. certificate	e-satibigeti	[esatɪ]

Clipping can be observed from the words listed (a)-(b). From the segments in (a) and (b), it can be inferred that it is the loss of many segments. When clipping occurs, whether many segments are lost, meaning is not lost. Therefore, it means there is morphological constraint that ensures that meaning is maintained. This can be MAX-IO_{SEMANTIC}. This constraint ensures that the output remains faithful to the input in terms of meaning. So this constraint in addition to other markedness constraints and faithfulness constraints will be ranked as follows to account for clipping in Ekegusii.

*CODA >> ALIGN [e] >> MAX-IO_{SEMANTIC} >> ALIGN (PrWd, L, Stem, L), >> IDENT-IO_{CONT}, DEP-IO(V)

(5.12) bathroom → {eβaβu}

/'ba:θrum/	*CO DA	ALIGN [e]	MAX- IO _{SEMANTIC}	ALIGN (PrWd, L, Stem, L),	IDENT- IO _{CONT}	DEP- IO(V)
a.  [e.βa.βu]				*	*	*
b. [βa.βu]		*!	*		*	
c. [e.βaβ]	*!		*	*	*	
d. [ba:θrum]	*!	*				

Candidate (a) is the most harmonic since it does not violate the high ranked markedness constraint but violates the low ranked faithfulness constraints that constrains clipping in Ekegusii. On the other hand, candidate (d) is the most disharmonic. It violates all the high ranked markedness constraints in the Ekegusii language which leads to its elimination. Candidates (b) and (c) are isoharmonic. They each violate one of the high ranked markedness constraints; ALIGN-[e] and *CODA, as a result, they are eliminated.

Gliding as a morphological process was reported in Ekegusii borrowing. Gliding is a morphological process whereby an adjacent vowel results in height assimilation leading to the formation of a glide. Gliding was observed in the following loanwords.

English I/P Gloss	Ekegusii Underlying Form	Ekegusii O/P	English
/swɪʃ/	[e.su.i.ci]	[e.swi.ci]	‘switch’
/'swetə/	[e.su.e. ⁿ ta]	[e.swe. ⁿ ta]	‘sweater’
/kəm'pju:tə/	[e.kə. ^m bi.u.ta]	[e.ko. ^m bjū.ta]	‘computer’

As evidenced from the data, adjacency of dissimilar vowel leads to glide formation at the morpheme boundary. For instance, the high back round vowel /u/ that is adjacent to the high front unround vowel /i/ the Ekegusii underlying form [e.sui.ci], cannot be realized as vowel /u/ because of the difference in horizontal tongue position. Consequently, it glides towards /w/ which is a glide. Similarly, in the Ekegusii underlying form [e.kə^mbiuta] the vowels /i/ and /u/ are adjacent. Whereas /i/ is [-back] and /u/ is [+back] makes the articulation of one after the other especially fast speech impossible. Hence, /i/ glides towards /j/ forming a glide. Lastly, is the Ekegusii underlying form [esueⁿta]. The two adjacent vowels /u/ and /e/ are dissimilar in terms of height. Subsequently, height assimilation takes place so that the high back round vowel /u/ is realized as a glide. Glide formation can be accounted for in Ekegusii using OT and GA constraints. If we illustrate using the input /'swetə/ ‘sweater’ adapted as [e.swe.ⁿta]; *[REDUCED-V] will be an appropriate markedness constraint. Also relevant are GA’s markedness constraints ALIGN-[e] which demand that the left edge of the prefix [e] must align with the left edge of the stem and ALIGN (PrWd, L, Stem, L) which require that the left edge of prosodic word aligns with the left edge of the stem. For the faithfulness constraints DEP-IO (V) which prohibits vowel insertion is relevant since the output violates it. The constraints will be ranked as follows in tableau 5.13:

*[REDUCED-V], >> ALIGN-[e] >> ALIGN (PrWd, L, Stem, L) >> DEP-IO(V)

(5.13) 'swetə' → {e.swe.ⁿta}

'swetə'	*[REDUCED-V]	ALIGN [e]	ALIGN (PrWd, L, Stem, L),	DEP-IO(V)
a.  [e.swe. ⁿ ta]			*	*
b. [swe. ⁿ ta]		*!		
c. [e.swe. ⁿ tə]	*!		*	
d. ['swetə]	*!	*		

Candidate (a) is the most harmonic. It does not violate any of the constraints that Ekegusii ranks highly in this case; *[REDUCED-V] which disallows the occurrence of the schwa and ALIGN-[e] which requires that the left edge of the prefix [e] must align with the left edge of the stem. On the other hand, candidate (d) is the most disharmonic. It violates all the high ranked markedness constraints in the Ekegusii language which leads to its elimination. As for candidates (b) and (c), they are isoharmonic. Each violates one of the high ranked markedness constraints; *[REDUCED-V] and ALIGN-[e] respectively. As a result, they are eliminated.

On morphological adaptations, Ekegusii mapped the loans to its various classes and the assignment of loans to various classes was constrained by OT and GA's constraints. Similarly, the Ekegusii morphotactic constraints determined the inflection of the loans

as well as the morphological processes. Conclusively, the interaction of OT and GA's constraints accounted for the morphological borrowing in Ekegusii.

5.5 Chapter Summary

This chapter has mainly explored morphotactics that constrained Ekegusii borrowing as well as morphological processes. First, Ekegusii noun morphology was discussed. Secondly, the morphological class adaptations were discussed, followed by inflectional and derivational morphology of loanwords as well as the morphological processes attested and how all of them are constrained by the morphotactics in Ekegusii. The interaction of OT's markedness and faithfulness constraints and GA's markedness constraints determined the optimal forms in the morphological class adaptations, inflectional and derivational morphology as well as the morphological processes in borrowed segments.

CHAPTER SIX

SUMMARY, CONCLUSIONS AND RECOMMENDATIONS

6.0 Introduction

This study examined how English loanwords are mapped into Ekegusii's phonology and morphology and how they are constrained by Optimality theory's markedness and faithfulness constraints. To achieve this main objective, answers to five questions were sought: First, what are the phonological adaptations of borrowed segments in Ekegusii? What are the phonological processes that shape the patterns of the borrowed segments in Ekegusii? What are the phonotactics of Ekegusii language that constrain borrowing? What are the morphological adaptations and morphotactics that shape the borrowed segments in Ekegusii borrowing and to what extent does Optimality Theory account for borrowing in Ekegusii? A summary of the findings is presented as per the research questions, followed by conclusions, then recommendations and finally outstanding issues as well as areas for further research.

6.1 Summary of Research Findings

The first research question sought to establish the underlying phonological adaptations of borrowed segments in Ekegusii. In this objective, the mapping of English vowels and consonants to Ekegusii in borrowing were explored. The findings revealed that that English vowels tend to be substituted with those in Ekegusii which they have shared features in terms of horizontal and vertical tongue position, tenseness as well as shape of the lips. Apart from the schwa whose adaptation was very mobile and unpredictable,

the front and back English vowels were mapped to Ekegusii's front and back vowels respectively. Thus, the high front unrounded vowel /ɪ/ was directly mapped from English to Ekegusii's /i/, however, in some loanwords it substituted the high front unrounded long vowel /i:/. This was attributed to the shared features of [+high, -back, -round]. Further, high front unrounded vowel /i/ was adapted in loanwords having the diphthong /əɪ/ since diphthongs are unattested in the language. OT accounted for this mapping in that the markedness constraint *DIPH which prohibits complex nuclei and shared feature [+high, -back, -round] which constrain the incoming input, gave rise to the faithfulness constraints IDENT-IO_{BACK} and IDENT-IO_{DIPH} which prohibits feature change between input and output. In this adaptation, the faithfulness constraints were dominated by the markedness constraints.

Another front vowel that was explored was the mid-high front unrounded vowel /e/. It was noted that besides direct mapping, it substituted the English vowels /ɪ/, /æ/, /ə/, /ɒ/ and the diphthong /eɪ/. It was noted that the mid-high front vowel /e/ shares the [-back, +lax] features with both /æ/ and /ɪ/ which necessitated the substitution. As for the schwa /ə/, it was simply realized as /e/ because it is a weak central vowel. The diphthong /eɪ/, undergoes reduction or mora loss to become /e/. In this mapping OT's markedness constraints *DIPH, which prohibits diphthongs and *[REDUCED-V] which forbids the schwa /ə/ since it is not attested in the Ekegusii language were proposed. These undominated markedness constraints dominated the faithfulness constraints like IDENT-IO_{DIPH} in this mapping.

Additionally on Ekegusii front vowels was the adaptation of /ɛ/, the mid-open front unrounded vowel. It substituted English loans which had /æ/, /ə/ and the diphthong /ei/. Similarly, the shared features here include; [-round, -back, -high]. This adaptation was accounted for using OT's the markedness constraint *DIPH which ensures no complex nucleus occurs in the Ekegusii language besides faithfulness constraints like DEP-IO(V) that forbids insertion, MAX-IO_{SEG} which disallows deletion and DEP-IO_{CONT} which forbids feature change.

Lastly on the front vowels was the Ekegusii open unrounded front vowel /a/, which substituted /æ/, /ɜ:/, /ə/, /ʌ/ and the diphthong /ei/. It was noted that /æ/, /ɜ:/ and /ə/ have shared features of [-back, +low, -round] which led to the subsequent mapping. As for the mid-open back unrounded vowel /ʌ/ it shares the features [+low] and [-round] while the diphthong underwent reduction.

As for the back vowels, the mid-close back rounded vowel /o/ in Ekegusii was very frequent in occurrence. It was adapted in loanwords which had /ɒ/, /ə/, /ʊ/, /ɔ:/ and the diphthong /əʊ/. It was noted that /ɒ/, /ɔ:/ /ʊ/ are close in terms of horizontal tongue position and lip rounding. The shared features being [+back, +round]; thus, the substitution. As for the schwa, it could have closed in towards /o/ phoneme since both are mid vowels in vertical tongue dimension. Absence of diphthongs in Ekegusii language justifies the reduction of /əʊ/ to a simply /o/ due to gliding to [+back, +round] position. Equally, OT's universal markedness constraints *CODA, *DIPH and *[REDUCED-V] were used to explain the adaptation of /o/ in Ekegusii. In this instance,

the markedness constraints dominated the faithfulness constraints and they were ranked as: *CODA, *DIPH, *[REDUCED-V] >> DEP-IO(V), IDENT-IO_{LONG/DIPH}.

Lastly, vowel adaptation of the round back vowel /u/ in Ekegusii was observed. It was mapped in all instances where we had the long back close round vowel /u:/ in English loanwords. It was noted that both share [+round, +back, +high] features. Further it was mapped in loanwords which had the low back unrounded vowel /ʌ/ and /ɔ/. Like in the adaptation of /o/, the markedness constraints *CODA and the faithfulness constraints IDENT-IO_{LONG} and DEP-IO(V) were used to account for this adaptation.

On consonantal segments, data revealed that the adaptation was guided by shared features which ensured that segments that are unmarked cross linguistically were adapted over the marked ones as follows. Firstly, the bilabial fricative /β/ was mapped in loanwords which had /b/, /p/, /v/ and /f/. All the four sounds share [+LAB, +ANT, -SON] features and they are obstruents. OT's markedness constraints *CODA, *[b], *[p] and *[CONT, LAB-DENT] which are ranked high in Ekegusii language and the faithfulness constraints DEP-IO(V) and IDENT_{VOICE/CONT/LAB} were posited to account for this adaptation.

Secondly, was the adaptation of the voiced velar stop /g/ to Ekegusii's /ɣ/, /k/ and /^hg/ respectively. All the three sounds are velars; besides, Ekegusii tolerates post nasal voicing; hence, the adaptation of the voiced pre-nasalized homorganic stop sound /^hg/. Also, the voiced alveolar stop /d/ was adapted to Ekegusii's voiceless alveolar plosive

/t/. The data revealed that the absence of the voiced alveolar stop /d/ necessitated the mapping and OT's markedness constraint *[OBSVOI] which prohibits the occurrence of voiced obstruents which are marked cross-linguistically accounted for this adaptation. Moreover, the voiceless alveolar stop in Ekegusii was adapted in loanwords which had the voiceless interdental fricative /θ/. Absence of the interdental in Ekegusii could explain the adaptation although both sounds share [-son, +ant, +cor] features. The undominated markedness constraint *[CONT, DENT] accounted for this adaptation. Further on the adaptation of voiceless obstruents, there were instances whereby those which were preceded by nasal underwent voicing. In this case, the markedness constraint *NÇ and *OBSVOI which disallow obstruent voicing were used to explain the realization of pre nasalized stops in Ekegusii.

Another adaptation was that of the voiceless alveolar fricative /s/ being adapted in English loanwords with /z/, /ʃ/ and /ʒ/. Absence of these three sounds in the Ekegusii inventory as well as the fact that coronals especially alveolars are the unmarked and if they are voiceless they are preferred cross linguistically explained the adaptation. The markedness constraints *CODA, *[ʃ], and *OBSVOI and the faithfulness constraints MAX-IO(V), IDENT-IO_{VOI} and DEP-IO(V) were used to account for the adaptation. Also, the absence of the lateral /l/ in Ekegusii inventory led to its mapping as /r/ driven by the markedness constraint *[LAT] that is undominated in Ekegusii constraint hierarchy.

Lastly, the adaptation of manner-contour consonants in Ekegusii was discussed. The data revealed that the English ‘mp’ and /ŋk/ are substituted with /^mb/ and /ⁿg/ respectively in Ekegusii. In both instances, post-nasal voicing led to the formation of pre-nasalized stops in Ekegusii which are phonemic in the language as is the case across Bantu languages. The markedness constraints *CODA and *NÇ as well IDENT-IO_{VOI/NAS} were used account to account for the mapping and they were ranked as: *CODA >> *NÇ >> IDENT-IO_{VOI/NAS}.

Also attested in the Ekegusii language was the voiceless palatal plosive /c/ which was mapped in instances where loanwords had the voiced palatal affricate /dʒ/. Its absence in the Ekegusii inventory could have motivated its mapping as well as the fact that voiceless obstruents are preferred cross linguistically.

The second research question sought to answer the question on the phonological processes that shape the patterns of the borrowed segments in Ekegusii. The following phonological processes were evident in Ekegusii borrowing: epenthesis, deletion, weakening/voicing and strengthening/devoicing, re-syllabification, substitution, lenition and monophthongization. Firstly, on epenthesis, the study noted that it was motivated by consonant cluster simplification either at syllable onset or coda and there was no predictable pattern governing the kind of vowel to be inserted. Therefore, OT’s markedness constraints *CO, *CN, *CL and *CG in addition to *CODA as well as the faithfulness constraints DEP-IO(V) and IDENT-IO_{VOI} were used to account for the phonological process of epenthesis in Ekegusii as a repair strategy against illicit clusters

Secondly, is deletion which took the form of aphaeresis and syncope. Aphaeresis was observed where the voiceless glottal fricative /h/ occurring word initially was deleted. Syncope was evidenced in the adaptation of /'bæp.tɪzəm/, 'baptism'; /bæp.'taɪz/; 'baptize' and /'dɪs.trɪkt/, 'district' which led to the subsequent deletion of /m/, /p/ and /t/. In all the instances, the motivation was to break cluster consonants which are disallowed in Ekegusii language. OT's markedness constraints *CODA and *CN, *[p] and faithfulness constraints MAX-IO(C) and DEP-IO(V) were used to account for deletion.

Thirdly is devoicing or strengthening which was observed when voiced obstruents which included the /z/, /d/, /ʒ/ and /dʒ/ were mapped as /s/, /t/, /s/ and /c/ respectively. This strengthening was motivated by the absence of the voiced obstruents in the Ekegusii inventory in addition to the fact that voiceless sounds are unmarked and cross-linguistically preferred over the voiced sounds. OT's markedness constraints *CODA and *[OBSVOI] as well as the faithfulness constraint of IDENT-IO_{VOI} and DEP-IO(V) were used to explain devoicing in Ekegusii. On the other hand, weakening or voicing took place where sounds /f/, /p/ and /k/ became /β/, /β/ and /ɣ/ respectively. Equally, the motivation here was absence of the voiceless sounds in Ekegusii apart from /k/. OT's the markedness constraints *[p], *CODA, *[CONT, LAB/DENT] and *CO_{ONS} as well as the faithfulness constraints DEP-IO(V) and IDENT-IO_{VOI} were invoked to account for the devoicing in Ekegusii.

Another phonological process witnessed was re-syllabification whereby English monosyllabic loans were replaced by disyllables and vowels inserted between clusters

or at the coda because of Ekegusii's open syllabicity. The *CODA constraint, which forbids the presence of consonants at the coda position was invoked. As for consonant clusters, *CO, *CN and *CL constraints were invoked as markedness constraints. Another markedness constraint in this category was *[CONT, LAB/DENT] which forbids the occurrence of labial dentals since they are not attested in the language. Further, the faithfulness constraints IDENT-IO_{CONT} and DEP-IO(V) were used to account for re-syllabification in Ekegusii and the constraints were ranked as: *CODA, *CO/*CN/*CL, *[CONT, LAB/DENT]>> IDENT-IO_{CONT}, DEP-IO(V).

Substitution also occurred in Ekegusii borrowing. On vowels, long /i:/ was realized as /i/, /æ/ as /e/, /a/ or /ɛ/, /ɜ:/ was realized as /a/, /ɒ/ as /o/ and one instance where it changed to /e/ and /ɔ/, /ɔ:/, /ʌ/ as /u/. As for the consonant sounds, the voiced bilabial fricative /β/ substituted /b/, /p/, /v/, /f/ while the voiced velar plosive /g/ was realized as /ɣ/, /k/, /ŋg/ in different environments. Also, /d/, /θ/ were adapted as /t/ while /z/, /ʃ/ /ʒ/ changed to /s/ and /l/ as /r/. On manner-contour consonants 'mp' was realized as /^mb/, while the English /ŋk/ was replaced by /ⁿg/ in Ekegusii, whereas the voiced palatal affricate /dʒ/ was realized as /c/. Mostly, substitution was driven by absence of a given sound in the Ekegusii inventory. Various constraints were employed to account for this phonological process depending on the category. Some of them included; *CODA, *DIPH, *[REDUCED-V] which dominated DEP-IO(V) and IDENT-IO_{LONG/DIPH} for vowels and *CODA, *[b], *[p], *[CONT, LAB/DENT], *[g], [-*[CONT, DENT], *OBSVOI, *NÇ, and *[LAT] that dominated MAX-IO_{SEG} which also dominated the faithfulness constraints DEP-IO(V) and IDENT-IO_{VOI/LAT/LAB/NAS/DISTR} for consonants.

Absence of diphthongs in the Ekegusii led to monophthongization. The findings revealed that the pure vowels that replaced the diphthongs in the loanwords had a similarity based on shared phonological features. For instance, /ei/ was adapted as either /e/ or /ɛ/, /əʊ/ as /o/ while /əɪ/ and /aɪ/ were substituted by /i/ and /e/ respectively. Monophthongization in Ekegusii was accounted for using OT's undominated markedness constraints; *DIPH and the dominated faithfulness constraints DEP-IO(V) and IDENT-IO_{DIPH}.

Further, lenition was observed in Ekegusii borrowing whereby the voiced bilabial plosive /b/ was mapped to the voiced bilabial fricative /β/ because of its absence in the Ekegusii inventory. To account for lenition, the universal markedness constraints *CODA and *[b] which forbid coda consonants and the occurrence of the bilabial plosive respectively were used. These constraints dominated IDENT-IO_{LAB/CONT} and DEP-IO(V) which prohibit feature change and insertion respectively.

The third research question sought to establish the phonotactics of Ekegusii language that constrain borrowing. The findings revealed that the phonotactics that constrain Ekegusii borrowing are at two levels: segmental and syllabic. At the segmental level, it was revealed that there are Ekegusii phonotactics that constraint the occurrence of both vowels and consonants. In the adaptation of vowels, it was established that Ekegusii has a phonotactic constraint that forbids the occurrence of diphthongs/triphthongs and it was formulated as *[DIPH] while *[REDUCED-V] prohibited the occurrence of the schwa.

On the consonants, there were quite a number of phonotactics formulated. First, is the phonotactic constraint that prohibits the occurrence of the consonants at the coda position and it was formulated as *CODA.

Secondly, the data revealed that there are more phonotactics which constrain specific occurrence of different consonantal segments. These phonotactics relate to the adaptation of labials, velars, sibilants, approximants, manner-contours and interdental. On labials it was observed that Ekegusii imposes phonotactic constraint *[b] and *[p] which constrain the occurrence of labials. As for labial dentals the proposed phonotactics was *[CONT, LAB-DENT] which ban the occurrence of segments that are not parsed as the bilabial fricative. Further, Ekegusii has a phonotactic constraint that governs the mapping of a velar to another that is present in the Ekegusii and it was formulated as *[g]. On sibilants data revealed that Ekegusii has a phonotactic that constrains the adaptation, and ensures that a strident is adapted to a fellow voiceless strident. This phonotactic was formulated as *OBSVOI and *[ʃ] and it ensured incoming loanwords were parsed as the voiceless alveolar fricative /s/.

Moreover, it was noted that Ekegusii has a phonotactic constraint that determines the mapping of approximants and laterals which was proposed as *[LAT] to account for the lack of lateral liquid in Ekegusii. Besides, the data revealed phonotactic constraints that govern the adaptation of manner-contour consonants. These were two; *NC̥ which prohibits occurrence of voiceless obstruents after a nasal and *[OBSVOI] which prohibits the occurrence of voiced obstruents. Similarly, on interdental Ekegusii

enforced the phonotactic *[CONT, DENT] to militate against the occurrence of dentals which are not attested in Ekegusii language.

Equally, on the syllabic level three phonotactic constraints were observed. First, the V syllable type, prohibition of cluster consonants, diphthongs or triphthongs; the phonotactics were formulated as *CODA, *CO_{ONS}, CL_{ONS}, *CN_{ONS} and *DIPH. Secondly, on the CV syllable structure, Ekegusii imposes a *CODA, *PEAK-C and *ONSET. Lastly on the CGV syllable, Ekegusii has a phonotactic constraint that ensures the occurrence of consonant followed by a glide, specifically the bilabial or the palatal /w/ or /j/ and a vowel due to the low ranking markedness constraint *CG in the language constraint hierarchy. Conclusively, we can note that both the segmental and syllabic phonotactics in Ekegusii determine that whatever is mapped in Ekegusii borrowing adheres to its syllable structure.

The fourth research question sought to answer the question on the morphological adaptations and morphotactics that shape the patterns of the borrowed segments in Ekegusii borrowing. To answer this question, first we explored the noun morphology of Ekegusii. Out of the 20 noun classes in Ekegusii, the borrowed segments were mapped to class 3 and 4, 7 and 8 as well as class 14 which comprised of inanimate referents. Majority of the loanwords were however, mapped to class 9 and 10 regardless of whether they were human referents or not. Also, few of the loanwords especially human referents were mapped to class 1 and 2 which is typically for human referents. On the mapping of the loanwords to Ekegusii, it was noted that the overriding factor

was the pre-prefix marker in Ekegusii whereby if the adapted loanword matches the Ekegusii pre-prefix the loan is assigned to that class. OT and GA's morphological constraints were used to explain how Ekegusii maps individual loanwords to its various classes. The morphotactics proposed were *CODA, ALIGN([e]_{AF}, L, Stem, L) which means that the left edge of the prefix [e] must align with the left edge of the stem. This markedness constraint is simplified as ALIGN-[e]. Also invoked was the morphotactics ALIGN (PrWd, L, Stem, L) which requires that each left edge of prosodic word aligns with the left edge of some stem. Faithfulness constraints invoked included: DEP-IO(V) which prohibits insertion of the class morpheme marker, MAX-IO_{SEG} which disallows segment deletion as well as IDENT-IO_{NAS/LAT/CONT} which prohibits feature change. Thus, the constraints were ranked as: *CODA >> ALIGN-[e] >> MAX-IO_{SEG} >> ALIGN (PrWd, L, Stem, L) >> IDENT-IO_{NAS/LAT/CONT}, DEP-IO(V).

On inflectional and derivational morphology, it was noted that to a large extent, loanwords undergo inflectional integration. Whereas English loans inflect for number which is typically suffixed, in Ekegusii the borrowed words are prefixed to express number. Further, the prefix selected was determined by the class the loan had been mapped to in Ekegusii. Some of the pre-prefixes expressing number in Ekegusii include: {ci-, e-βi-, a-ma-, e-me-}. It was noted that class 9 /10 formed the plural by dropping the class morpheme marker 'e' and introducing a prefix {ci-} while 3 /4, took {e-me-}, 7 /8 selected {e-βi-} and 14 {a-ma-}. OT and GA's constraints, *CODA, ALIGN-[Affix] and ALIGN (PrWd, L, Stem, L) were invoked as well as the faithfulness constraints MAX-IO_{SEG}, DEP-IO(V) and IDENT-IO_{LAT/NAS/VOI} to account

for pluralisation in various classes. The constraints were ranked as follows: *CODA >> ALIGN-[Affix] >> ALIGN (PrWd, L, Stem, L) >> MAX-IO_{SEG} >> DEP-IO(V), IDENT-IO_{LAT/CONT/NAS}.

Further on inflection morphology, it was observed that in Ekegusii borrowing, the loans did not inflect for gender since the language does not have an overt prefix or suffix to mark gender. However, loanwords borrowed into Ekegusii denoting gender were adapted and native speakers could infer if they are referring to either male or female. This mapping was accounted for by invoking the undominated *CODA constraint, ALIGN-[e] and ALIGN (PrWd, L, Stem, L). As for the faithfulness constraint, DEP-IO(V) which prohibits vowel insertion was used and they were ranked as: *CODA, *DIPH >> ALIGN-[e] >> ALIGN (PrWd, L, Stem, L) >> DEP-IO(V).

On derivational morphology, only one instance was realized whereby the noun /'bæptɪzɪm/ adapted as a [eβatɪso] 'baptism' was derived to form a /bæp'taɪz/ a verb adapted as [βatɪsa]. Generally, derivation was very minimal compared to inflection. Similarly, OT's markedness and faithfulness constraints were invoked to account for the adaptation and the constraint hierarchy was as follows: *CODA >> *ALIGN-[e] >> MAX-IO_{SEG} >> ALIGN (PrWd, L, Stem, L).

Lastly, morphological processes were examined. The data of the loanwords analysed showed that Ekegusii reports clipping, pre-prefixation and gliding as morphological processes. Clipping was accounted for using OT and GA's markedness and faithfulness

constraints. $MAX-IO_{SEMANTIC}$ constraint which ensured that the output remains faithful to the input in terms of meaning was proposed besides other markedness constraints. The markedness constraints dominated the faithfulness constraints and were ranked as: $*CODA \gg ALIGN [e] \gg MAX-IO_{SEMANTIC} \gg ALIGN (PrWd, L, Stem, L) \gg IDENT-IO_{CONT}, DEP-IO(V)$.

Pre-prefixation was another morphological process reported in Ekegusii borrowing. It was noted that in pre-prefixation, Ekegusii attaches a double prefix to a loanword. Pre-prefixation was accounted for using GA markedness and OT's markedness and faithfulness constraints. The constraints proposed included: $*CODA$, $*[REDUCED-V]$ and $*CO_{ONS}$ which are all undominated. GA's proposed constraints include: $ALIGN-[e]$ and $ALIGN (PrWd, L, Stem, L)$. For the faithfulness constraints $DEP-IO (V)$ and $IDENT-IO_{CONT}$ were proposed. The markedness constraints dominated the faithfulness constraints and they were ranked as follows: $*CODA, *[REDUCED-V], *COONS \gg ALIGN-[e] \gg ALIGN (PrWd, L, Stem, L) \gg DEP-IO(V), IDENT-IO_{CONT}$.

Lastly on morphological processes was gliding. It was observed where an adjacent vowel resulted in height assimilation leading to the formation of a glide when the loanword was adapted. Gliding in Ekegusii was accounted for using OT and GA constraints, whereby the markedness constraints dominated the faithfulness constraints. The constraint hierarchy was as follows: $*[REDUCED-V] \gg ALIGN-[e] \gg ALIGN (PrWd, L, Stem, L) \gg DEP-IO(V)$

6.2 Conclusions

Based on the research findings established from this study, possible specific conclusions can be drawn. First, that universal markedness and faithfulness constraints when appropriately identified and ranked can adequately account generally for morphophonological borrowing in Ekegusii.

Specifically on the phonological adaptations of borrowed segments, the constraints determined what is permissible and what is not permissible in the Ekegusii language. The constraints ensured that the mapping was guided by segments that are available in the Ekegusii inventory and specifically those that are unmarked and therefore preferred cross linguistically.

Secondly, we can infer that the phonological processes that shape the patterns of the borrowed segments in Ekegusii were determined by the markedness constraints which dominated the faithfulness constraints. On this, illicit combinations were repaired by various phonological processes leading to only what is acceptable in the language. In fact, Ekegusii outputs were seen to consistently violate the anti-epenthesis constraints and feature change than the anti-deletion faithfulness constraints. So, it was inferred that though faithfulness constraints were dominated by markedness constraints, MAX-IO_{SEG} dominated IDENT-IO(F) and DEP-IO(V).

Thirdly, Ekegusii has phonotactics both at the segmental and syllabic level that guide the adaptation. This phonotactics though language specific drew their formulations from

the universal markedness and faithfulness constraints that are ranked in a language specific manner; Ekegusii language constraint hierarchy. In this language constraint hierarchy markedness constraints crucially dominate the faithfulness constraints.

On morphological adaptations, we can conclude that GA's markedness and OT's markedness and faithfulness to a large extent determine first the morphological class mapping of loanwords, then the inflection of the loanwords and derivation as well as the morphological processes that the loanwords undergo in Ekegusii borrowing. In a nutshell, the markedness constraints dominated the faithfulness constraints.

6.3 Recommendations

In making our recommendations, first we make recommendations for the general linguists, for the theorists and finally, for the general public. To begin with is the basic claim by Optimality Theory that the grammar of all languages can be accounted for by ranking constraints which are part of Universal Grammar or the innate language knowledge that humans have. Thus, any linguistic phenomenon can be accounted simply by ranking constraints. Basic to any linguistic theory is the assumption that such theory can account for the language acquisition in children. Considering the many constraints that will have to be mastered and ranked crucially so as to account for language acquisition in children, OT's complexity does not explain the ease with which children acquire language.

Secondly, OT claims that any phonological phenomenon observed in any language can be fully explained by ranking constraints which are language specific. This was the case of borrowing in Ekegusii. To a large extent, OT accounted for phonological adaptations that were sought in the first objective of the research. It also accounted for various phonological processes as well as the Ekegusii phonotactics that constrain borrowing both at the segmental level and syllabic level. However, there were instances that OT did not provide sufficient explanations. This includes post nasal voicing. Evidently, Ekegusii allows both post nasal voicing and post nasal devoicing. In this case, OT's absolute notion of constraint domination whereby the satisfaction of one constraint is designated to take absolute priority over the satisfaction of another does not apply. Similarly, the fact that a grammar uses strict domination hierarchy to resolve conflicts by ranking constraints in a given language does not apply either. Hence, we recommend that OT includes variable ranking to explain the phenomenon in Ekegusii's post nasal voicing and devoicing or co-phonology. This theory allows markedness constraints to have one ranking in some morphological construction(s), and the opposite ranking in others whereas classical OT that is committed to strict constraint domination does not allow this, as the ranking of markedness constraints is fixed for a language (Downing, 2008).

Everyday loanwords are borrowed into languages to accommodate technological advancements and language changes. It is a phenomenon that is very common and unavoidable. Linguists locally and beyond can therefore pay morphophonological attention to some of these processes in a bid to establish how languages integrate

loanwords and how they rank their constraints. Optimality Theory is essentially interactions of markedness and faithfulness constraints to determine language grammars. Linguists can explore how languages of the world rank their constraints which then will explain linguistic variability.

To a large extent, this study explored how segments (consonants and vowels) from English are mapped to Ekegusii. The mapping was necessitated by native speaker knowledge which ensured that only segments available in the native speaker's inventory were selected in the event of borrowing. Hence, a recommendation is made to the general public that whenever speakers 'mispronounce' words as often is perceived, it is not necessarily a reflection of their inability to pronounce words well but, rather phonological repair adjustments initiated by the phonotactics of their first language.

6.4 Outstanding Issues and Areas of Further Research

While OT accounted for borrowing in Ekegusii in most instances, there are phonological phenomena that could not be explained. Such instances include the presence of consonantal sounds like [ʰs], [ʰt] and [ʰc]. These could not be explained by *NÇ which prohibits post nasal devoicing or *OBSVOI which militates against obstruent voicing or pre-nasalization which is typical of Bantu languages. These instances require further investigation so as to account for their occurrence in Ekegusii language.

Further, OT accounted for the mapping of vowel sounds. In fact, it was noted that English vowels tended to be substituted with those in Ekegusii which they have shared features in terms of horizontal and vertical tongue position, tenseness as well as shape of the lips. However, there were unusual patterns where English back vowels /ɒ/ and /ʌ/ were adapted to Ekegusii /e/ and /a/ respectively. OT's constraints could not account for this mapping therefore it requires re-evaluation.

On morphological adaptations, specifically on the insertion of the morpheme {e}, predictably most loanwords insert it word initial. However, there are instances where {o} was inserted and it could not be explained. A case in point was the adaptation of /'blæŋkɪt/ as [o-βoraŋgetɪ] 'blanket' yet there are other loanwords which you could expect to insert {o} like /'bəʊlt/ adapted as [eβoritɪ] 'bolt' and /bɒks/ as [eβoɣɪsɪ] 'box'. This too requires further re-examination because it contradicts the morphotactic ALIGN-[e] which requires that the left edge of the prefix [e] must align with the left edge of the stem and it is the one that accounted for the pre-prefixation of most loans in Ekegusii.

Besides the outstanding issues, there are specific areas that will need future research to look at. This study explored a morphophonological analysis of loanword adaptations in Ekegusii. Other aspects of the loanwords could be explored like the semantic and syntactic integration so as to determine how they are constrained by OT's markedness and faithfulness constrains.

Data analysis on morphological adaptations revealed that loanwords easily undergo inflection than derivation when adapted to Ekegusii making inflection more productive than derivation. This is contrary although literature shows that loanwords have limited derivational paradigm. Native Ekegusii lexemes could be explored to determine their derivational paradigm and establish how the derivational process is constrained in Ekegusii by OT's constraints. The one example that was used to account for derivation in loanwords does not give a clear picture of derivational morphology on loanwords in Ekegusii.

Moreover, Generalized Alignment was used to account for Ekegusii's morphological adaptations and it was simply limited to the alignment of the left edge of the prefix [e] with the left edge of the stem edges as well as aligning the left edge of the prosodic word to the left edge of a stem. Considering that Ekegusii is a Bantu language which is tonal, and the donor language in this case was English which is a stressed language, alignment could be extended to other prosodic categories like mora, syllable and foot so as to determine how stress is mapped to the Ekegusii tone and how it is constrained.

Lastly, the study explored the syllable and how it constraints borrowing giving rise to the different phonotactics that we proposed in Ekegusii. More could be done on the syllable considering others prosodic aspects like intonation and pitch contours typical of the English language and how they are adapted to Ekegusii's tonal system. Similarly, these aspects could be extended to other linguistic groups so as to compare the phonotactics that other languages impose on incoming loans.

References

- Abrahamson, M. (1983). *Social research methods*. Englewood Cliff: Prentice-Hall
- Aljumah, H. A. (2008). The syllable shape of Al-Asha dialect: An OT perspective. *Poznan in Contemporary Linguistics*, 44(2), 155-177
- Anyona, M. G. (2016). Syllabic nativization of Ekegusii loanwords from English: An Optimality Theory approach. *Elixir International Journal*, 10, 44094-44099.
- Ayuni, S., R. (2012). Phonological processes of Indonesian borrowing words used by Minangkabau. Bukittinggi, West Sumatra.
- Appel, R. & Muysken, P. (2005). *Language contact and bilingualism*. London: Edward Arnold.
- Archangeli, D., Moll, L., & Ohno, K. (1998). Why not *NÇ. Chicago. *Chicago Linguistic Society*, 34,1-26.
- Bickman, L & Debra, J. R. (2009). *Applied social research*. London: Sage Publications.
- Bickmore, L. (1997). Problems in constraining High Tone spreading in Ekegusii. *Lingua*, 102(4), 265-290.
- Blevins, J. (1995). The syllable in phonological theory. In J. Goldsmith (Eds.), *The handbook of phonological theory*. Cambridge Mass: Blackwell.
- Bowern, C. (2008). *Linguistic fieldwork: A practical course*. New York: Palgrave Macmillan
- Btoosh, A. M. (2006). Constraint interactions in Jordinian Arabic phonotactic: An Optimality Theoretic approach. *Journal of Language and Linguistics*, 5 (2), 192-221.
- Cammenga, J. (2002). *The phonology and morphology of EkeGusii – A Bantu language of Kenya*. Koln: Rudiger Koppe Verlag.
- Chacha, L. M. (2009). The adaptation of Swahili loanwords from Arabic: A constraint based analysis. *Journal of Pan African Studies*, 2 (8), 46-61.
- Chelliah, L. S. & Reuse, W. (2011). *Handbook of descriptive linguistic fieldwork*. New York: Springer.

- Chomsky, N. & Halle, M. (1968). *The sound pattern of English*. New York: Harper & Row
- Chomsky, N. (1977). On Wh-movement. In Culicover, P. et al (eds). *Formal syntax*. New York: Academic Press 71-132
- Clark, J. & Yallop, C. (2007). *An introduction to phonetics and phonology*. Cambridge: Cambridge University Press.
- Cooper, J. & Vaux, B. (2003). *Introduction to linguistic field methods*. Muenchen: Lincom Europa
- Corbin, J. & Strauss, A. L. (1998). *Basics of qualitative research* (2ndedn). Thousand Oaks CA: Sage Publications.
- Cruttenden, A. (2014). *Gimson's pronunciation of English*. London: Routledge.
- Davis, S. (1993). Loanword, phonological treatment. *The Encyclopedia of Language Linguistics*, 2273-2276. Oxford and New York: Pergmon Press.
- Dey, I. (1993). *Qualitative data analysis*. London: Routledge.
- Downing, L., J. (2008). Co-phonologies and morphological exponence in OT. 3rd Exponence Network Meeting and Workshop on Theoretical Morphology 4 University of Leipzig (GroBbothen), 20-21June, Zas, Berlin.
- Dubach, G., A. (2002). *Word, foot and syllable structure in Burmese*. University of Potsdam. Retrieved from: www.roa.rutgers.edu/content/article/files
- Tsvetkor, Y. & Dyer, C. (2016). Cross-lingual bridges with models of lexical borrowing. *Journal of Artificial Research*, 55, 63-93.
- Bosire, K., M. & Machogu, G., K. (2013). *Ekegusii English Dictionary*. The Republic of Kenya: Ekegusii Encyclopaedia Project.
- Faezeh, F. & Zafaranlu, A., K. (2013). Germany loanwords adaptation in Persian: Optimality approach. *International Journal of Humanities*, 20(4), 23-40.
- Fatimah, D. & Abdulmohsen, A. D. (2017). Morphological adaptation of English loanwords in Twitter: Education implication. *International Journal of Higher Education*, 6(3), 231-248.
- Flemming, E. (2004). Contrast and perceptual distinctiveness. In B. Hayes, D. Steriade & R. Kachner. (Eds.), *Phonetically-based phonology*. New York: CUP.
- Fossi, A. (2012). Cultural and linguistic hybridization in Cameroon: English loanwords in Ngãmbã . *International Journal of Linguistics*, 4 (1)

- Grey, E. D. (2009). *Doing research in the real world*. London: Sage Publications.
- Gordon, W. (2003). *Goodthinking: A guide to qualitative research*. Admap UK: Henley - on - Thames.
- Gussenhoven, C. & Jacobs, H. (2005). *Understanding phonology*. London: Hodder Education
- Guthrie, M. (1971). *Comparative Bantu: An introduction to the comparative linguistics pre history of the Bantu languages 2*. Farnborough: Gregy Press.
- Hafez, O. (1996). Phonological and morphological integration of loanwords into Egyptian Arabic. *Les Langues en Egypte*, 27-28
- Hall-lew A. L (2002). *English loanwords in Mandarin Chinese*. Masters' Thesis, University of Arizona.
- Hammond, M. (1994). *An OT account of variability in Walmartjari stress*. Retrieved from: www.roa.rutgers.edu/files/20-0794/20-0794
- Harb, A. M. (2014). *An optimality-theoretic account of English loanwords in Hawaiian*. Retrieved from: www.roa.rutgers.edu/content/article/files/1337
- Harb, M., A. & Al-Jarrah, R., S. (2014). *An optimality account of English loanwords in Hawaiian*. Retrieved from: www.roa.rutgers.edu/content/article/files/1216.
- Hashemi, S. E. & Kambuziya, Z. K. A. (2011). *Russian loanword adaptation in Persia: Optimal approach*. Tarbiat Modares University, Tehran, Iran.
- Haunz, C. (2003). *Grammatical and Non-grammatical factors in loanword adaptation*. Taali University of Edinburgy
- Henn, M., Weinstein, M. & Foard N. (2006). *A short introduction to social research*. London: Sage Publications
- Hoffer, L., B. (2005). Language borrowing and the ideas of adaptability and receptivity. *Intercultural Communication Studies*, 9. Retrieved from <http://www.uri.edu/iaics/content/2002v11n4/01%20Bates%20L.%20Hoffer.pdf>
- Homan, S. & Boersma, P. (2008). *Loanword adaptation as first-language phonological perception*. Retrieved from: www.roa.rutgers.edu/content/article/files.
- Hyunsook, K. & Davis, S. (2006). *English loanwords and the word final [t] problem in Korean*. Indiana University and Hanyang University.
- Iribemwangi, P., I & Karuru, D., W. (2012). Phonological adaptation of Kiswahili

- loanwords into Gĩ-Gĩchũgũ dialect of Gĩkũyũ language. *Baraton Interdisciplinary Research Journal*, 2(2), 49-62.
- Johnson, K. (2008). *Quantitative methods in linguistics*. Wiley: Blackwell.
- Kager (1999). *Optimality Theory*. Cambridge: Cambridge University Press.
- Kahn, D. (1976). *Syllable-based generalizations in English phonology*. PhD dissertation, Massachusetts Institute of Technology. Malden Mass: MIT Press.
- Kambuziya, Z. K., Hashemi, E., S., Aghagolzade, F. & Golfam, A. (2014). Phonological adaptation of Arabic loanwords in Persia: Consonants. *Internal Journal of Humanities and Social Sciences*, 4(6), 225-236.
- Katamba, F. (1993). *Morphology*. London: Macmillan Press Ltd.
- Katamba, F. (1996). *An introduction to phonology*. New York: Longman Group.
- Katamba, F. (2003). *The Bantu languages*. London: Curzon Press.
- Kenstowicz, M. (2005). The phonetics and phonology of loanword adaptation. In: Rhee, S. J. (ed.). *Proceedings of ECKL 1: Proceedings of 1st European Conference on Korean Linguistics*. Seoul: Hankook Publishing Co, pp. 17-32.
- Kenstowicz, M & Kisseberth, C. (1977). *Topics in phonological theory*. New York: Academic Press
- Kenstowicz, M. & Atiwong, S. (2004). *Issues in loanword adaptation: A case study from Thai*. Phonology Conference: Manchester
- Kenya National Bureau of Statistics. (2010). *2009 Kenya population and housing census: Population distribution by age, sex, and administrative units (Volume 1c)*. Nairobi: Government Press.
- Kioko, A. N. & Muthwii, M. J. (2001). The demands of a changing society: English in education in Kenya. *Language Culture and Curriculum*, 14 (3), 201-213.
- Komenda, S., Maroko, G., M., Ngungu, W., R. (2013). The morphophonemics of vowel compensatory lengthening in Ekegusii. *International Journal of Education and Research*, 1(9), 1-16.
- Kristo, L. (2000). Words and meaning: Arbitrariness, listing, lexicalisation. In Kathleen, E.Dubs (eds). *What does it mean*. Pazmany Papers in English and American Studies, 2, 248-270.
- Ladefoged, P. (2003). *Phonetic data analysis: An introduction to fieldwork and instrumental techniques*. Oxford: Blackwell Publishing.

- Ladefoged, P. & Johnson, K. (2011). *A course in phonetics*. Wadsworth: Michael Rosenberg
- Lewis, M., P. (2009). *Ethnologue: Languages of the World*. Sixteenth eds. Dallas: SIL International. Available at: <http://www.ethnologue.com>
- Liberman, A. M. (1995). *The motor theory of speech*. Ms. Bell Laboratories.
- Maddieson, I. (1984). *Patterns of sounds*. Cambridge: Cambridge University Press.
- Maho, J. F. (2008). *The Bantu bibliography (African linguistic bibliography)*. Koln: Rudiger Koppe Verlag.
- Mangrio, R. A. (2016). *The morphology of loanwords in Urdu: The Persian, Arabic and English strands*. Cambridge: Cambridge Scholars Publishing.
- Mathkour, A., H. (2012). Morphological analysis of Jordanian colloquial Arabic loanwords : The case of cars and transportation. Unpublished Paper. Retrieved from <http://ijhe.sciedupress.com>
- Mavoungou, A. P. (2002). Sociolinguistic and linguistic aspects of borrowing in Yilumbu. *South African Journal of African Languages*, 22(1), 18-41.
- Mavoungou, A. P. (2005). Loanwords in Yilumbu: A morphological, semantic and lexicographical perspective.
- Mazrui, A. M. & Mazrui, A. (1993). Dominant languages in a plural post-colonial society: English and Kiswahili in post-colonial East Africa. *International Political Science Review*, 44(3), 275-292
- McBurney, H. D. & White, T. L. (2010). *Research methods*. U.S.A: Wadsworth.
- McCarthy, J. J. & Prince, A. S. (1993a). Generalized alignment. In Booji, G. E. & Van Marie, J. (Eds.), *Yearbook of Morphology*. Dordrecht: Kluwer.79-153
- McCarthy, J. J. & Prince, A. S. (1993b). *Prosodic morphology I: Constraint interaction and satisfaction*. University of Massachusetts and Rutgers University.
- McCarthy, J. & Prince, A. (1995). Faithfulness and reduplication identity. *University of Massachusetts Occasional Papers*, 18: 249-384
- McCarthy, J. J. (2002). *A thematic guide to Optimality theory*. Carlbridge: Cambridge University Press.
- McCarthy, J. J. (2004). *Optimality theory in phonology: A reader*. Malden, MA: Blackwell.

- McMahon, M.S. (1999). *Understanding language change*. Cambridge: Cambridge University Press.
- Miao, R. (2005). Loanword adaptation in Mandarin Chinese: Perceptual, Phonological and sociolinguistic factors. Unpublished Doctoral Dissertation, State University of New York: Stony Brook
- Mingazova, N. & Fattkhova, A. (2015). Arabic loanword in Tatar and Swahili: Morphological assimilation. *Journal of Sustainable Development*, 8(4), 302-308
- Mira, O. & Syejeong, K. (2012). Morphological effects in loanword adaptation: Adaptation of English plural suffix into Korean. *Linguistic Research*, 29(2), 299-314.
- Mogaka, R. (2009). Fonologia ya maneno mkopo ya Ekegusii kutoka Kiswahili. MA thesis, Kenyatta University, Kenya.
- Morelli, F. (2003). The relative harmony of /s +stop/obstruent). In C, Fery & R. van der Vijver (Eds.), *The syllable in optimality theory*. Cambridge: CUP.
- Mose, E., Mwangi, P. & Njoroge, M. (2013). Harmonizing the orthographies of Bantu languages: The case of Gikuyu and Ekegusii in Kenya. *University of Nairobi Journal of Language and Linguistics*, 3, 109-121
- Kadenge, M. & Mudzingwa, C. (2012). Comparing Chishona loanwords of monolingual and bilingual speakers: An optimality theory analysis. *South African Journal of African Linguistics*, 32 (2), 141-151.
- Mustafa, M. R. (2013). Local assimilation of consonants in English and Kurdish in the light of Optimality Theory. PhD Thesis, Koya University, Federal Republic of Iraq.
- Mwihaki, A.N. (1998). Loanword nativization: A generative view of the phonological adaptation of Gĩkũyũ loanwords (Unpublished PhD thesis). Kenyatta University, Nairobi
- Nagy, R. (2010). The phonological integration of loanwords in Dutch. PhD Dissertation, Budapest.
- Nandelenga, S., H. (2013). Constraint interaction in the syllabic phonology of Lubukusu: An optimality theory account. PhD Thesis, Kenyatta University, Kenya.
- Ndambuki, B., M. (2013). A constraint-based analysis of Kikamba nativized loanwords.

MA thesis, Kenyatta University, Kenya.

- Newman, P. & Ratliff, M. (2001). *Linguistic fieldwork*. Cambridge: Cambridge University Press.
- Ngorosho, D. & Alcock, K., J. (2004). Interaction between phonological and grammatical processing in single word production in Kiswahili. *Language and Speech*, 46 (1), 1-30
- Nurse, D. & Philipson, G. (2006). *The Bantu languages*. London: Routledge.
- Nyakundi, P., M. (2010). Motivation, morpho-phonological processes in Egesembesa Argot among Ekegusii-Speaking males of western Kenya. (Unpublished master's thesis). Kenyatta University, Nairobi, Kenya.
- Oh, M. (2012). Adaptation of complex words into Korean. *Journal of East Asian Linguistics*, 21 (3), 267-304
- Ohsio, M. (1973). A phonological study of some English words in Japanese. *Working Papers in Linguistics*, 14, 1-26.
- Ogechi, N., O. & Kembo-Sure, S. (2006). *Language planning for development in Africa*. Eldoret: Moi University Press.
- Pakerys, J. (2016). Morphological adaptations of adjectival borrowings in Modern Lithuanian. *Baltistica LI* (2), 239-269. Doi10.15388/Baltistica.51.2.2273.
- Paradis, C. (1996). The Inadequacy of filters and faithfulness in loanword adaptation. In Durand, J. & Laks, B. (Eds). *Current trends in phonology*. Salford: University of Salford Publications.
- Paradis, C. & Prunet, F. (1991). *The special status of coronals: Internal and external evidence*. San Diego: Academic Press.
- Paradis, C., & Prunet, F. (1994). Contrasts from Segmental Parameter Settings in Loanwords: Core and Periphery in Quebec French. In C. Dyck (Eds.), *Toronto Working Papers in Linguistics 13, The phonotactic adaptation of English loanwords in Arabic*, 60 (1). *Proceedings of the MOT conference on contrast phonology*, 75-94
- Pater, J. (1999). Austronesian nasal substitutions and other NC effects. In R. Kager, R., vander Hulst, H. & Zonneveld, W. (Eds.), *Phonology-morphology interface*. Oxford: OUP.
- Prince, A. & Smolensky, P. (1993). *Optimality theory: Constraint interaction in generative grammar*. New Brunswick, NJ: Rutgers University.

- Prince, A. & Smolensky, P. (2004). *Optimality Theory: Constraint interaction in generative grammar*. Maiden: Blackwell Publishing.
- Ritcher, C., G. (1984). *Lexical borrowing in Mandarin Icelandic and syllable structure constraints*. ERIC ED 311708
- Roach, P. (2009). *English phonetics and phonology*. Cambridge: Cambridge University Press
- Rungruang, A. (2007). English loanwords in This and Optimality Theory. Unpublished PhD, Naresuan University, Phisanulok, Thailand.
- Russ, C., V. (1992). English in contact with other languages: English loans in German after 1945. *New York Papers in Linguistics*, 16, 101-149
- Saidat, A. (2011). English loanwords in Jordanian Arabic: Gender and number assignment. *Language Forum*, 37(1), 59-71
- Sarkar, T. (2012). *Loanword adaptation in Bangla: An optimality theoretic account*. MA thesis, The English and Foreign Languages University. Hyderabad, India.
- Saleh, A. J. & Jarrah, R., S. (2013). English loanwords spoken by Madinah Arabic speakers. *Arab World English Journal*, 4(2), 67-85.
- Sayahi, L. (2005). *Phonological adaptation of Spanish loanwords in Northern Moroccan Arabic*. Retrieved from <http://repository.upenn.edu/pwpl/vol11/1551/20>
- Silverman, D. (1992). Multiple scansion in loanword phonology. *Phonology*, 9, 289-328.
- National Council for Law Reporting (2010). *The Constitution of Kenya, 2010*. Published with the Authority of the Attorney General.
- Tonks, P. & Demuth, K. (2002). Sesotho loanwords: Phonological vs. semantic incorporation. presented at the *24th Annual Meeting of the German Linguistic Society (DGfS)*, Mannheim, Germany.
- Vitale, A. J. (1982). Problems of stress placement in Swahili. *Studies in African Linguistics*, 13(3), 325-330.
- Wa Mberia (2004). The phonology of borrowed words in Kitharaka. *Occasional Papers in Language and Linguistics*, 2, 45-57. <http://hdl.handle.net/11295/89513>
- Welmers, W. (1973). *African language structures*. Berkeley and Los Angeles: University of California Press.

- Wiltshire, R. C. (2003). Beyond codas: Word and phrase final alignment. In C. Fery & R. van der Vijver (Eds.), *The syllable in Optimality theory*. Cambridge: CUP.
- Whiteley, W., H. 1956 (1960). *The Gusii tense system*. Kampala: East African Institute of Social Research.
- Zafaranlu, K. A., & Hashemi, S., E. (2011). Russian loanwords adaptations in Persian; Optimal approach. *Iranian Journal of Applied Linguistic Studies*, 3(1), 1-17.
- Zuzana, B. (2014). Loanword integration: A case of Kishajom Romini. *Romani Studies*, 24(1), 7-22.

APPENDIX 1: INTERVIEW GUIDE FOR RESPONDENTS

Instructions: *Ask the respondents to read the words provided, tape record and take notes.* **Questions**

Q1. Read for me the following words in the Ekegusii language: (Word list).

Eaburoni, eabutamu, eambiurensi, ebagitori, ebagiti, ebandechi, ebetiri, ebetirori, ebigibigi/, ebini, ebiro, ebogisi, ebota, ebositi, eburasita, ebureki, ebuti, eeka, echimuni, egarani, egari, egeita, ekeragita, egia, egita, ekaa, ekabati, ekabichi, ekabuteni, ekabuti, ekambani, ekambi, ekamera, ekara, ekarati, ekarenda, ekatoni, ekerasi, ematatu, emeito, eneti, engaseti, erore, eroni, erura, esitaeri, esitambu, esitech, esiteki, esiteseni, esito, esitoki, esituri, etaeri, etarumbeta, etauro, eteni, etigiti, etimu, etisirigiti, etamosi, eturansiba, eturera, ebekeri, ebengi, ebatiso, batisa, ebeneti, ebiri, eboriti, ebuti, ebonu, ekabeti, echibu, echeki, obisi, esiringi, esiring'i, eradio, ekateni, eirio, etibi, etisiu, erimoti, etikota, ewaya, esituri, etaoni, egesuguti, esuguri, ekorido, abaturumu, esoba, etoi, echagi, egasi, ebisito, eturera, eburasigiti, bibiti, esukuru, ekombiuta, besibuku, ebagi, esogeti, eroki, ebesiti, eroya, esuti, eswichi, eburemu, etisati, esako, ebisi, egaoni, esati, esigati, ekaonti, egabana, eseneta, rinoti, uburasi, esiribu, ekondagita, eturabu, eriberandamu, eyunibasiti, eibadi, ewaini, oborangeti, ebiro, ekosoni, esuti, etigiri, esatibigeti, ebomu, ekoteina, risiti, eturei, ekuka, esitobu, eturori, ereri, esitea, chisitea, ebarikoni, ebeseni, eswenta, etasita, eotiboti, ebiusi, eakaonti, emirioni, echamba, eboriti, echuisi, ekeki, erechesita, etumasita, eburinsibo, echamani, esekeretari, etesiki, ekabineti, ekerasi, ebeiri, amasini, ewayamesi, ekiriniki, ebubusera, ekesi, ekesia, eturesara, ereseni, eresesi, ebigimi, echati, echacha, eirio, echageti, erikobita, eyabukamisi,

Respondent A: _____ Sign: _____ Date: _____

APPENDIX II : ENGLISH LOANWORDS IN EKEGUSII

English Loanword	Output English	Ekegusii Word	Output Ekegusii
1. apron	/ˈeɪprən/	eaburoni	[e.a.βuroni]
2. half-term	/hɑːf.tɜːm/	eabutamu	[e.a.βutamu]
3. factory	/ˈfæktəri/	Ebagitori	[eβayitori]
4. ambulance	/ˈæmbjələns/	eambiurensi	[e.a.mbjurensi]
5. packet	/ˈpækɪt/	ebageti	[eβayeti]
6. bandage	/ˈbændɪdʒ/	abandechi	[eβa ⁿ deci]
7. battery	/ˈbætəri/	ebetiri	[eβetiri]
8. petrol	/ˈpetrəl/	ebetirori	[eβetirori]
9. pin	/pɪn/	ebini	[eβini]
10. box	/bɒks/	ebogisi	[eβoyisi]
11. biro	/ˈbɛɪrəʊ/	ebiro	[eβiro]
12. plaster	/ˈplɑːstə/	eburasita	[eβurasita]
13. post	/pəʊst/	ebositi	[eβositi]
14. brake	/breɪk/	ebureki	[eβureki]
15. bakery	/ˈbeɪkəri/	ebekeri	[eβekeri]
16. bank	/bæŋk/	ebengi	[eβe ^ŋ gɪ]
17. baptism	/ˈbæptɪzəm/	ebatiso	[eβatiso]
18. baptize	/bæpˈtaɪz/	batisa	[βatisa]
19. bonnet	/ˈbɒnɪt/	ebeneti	[eβeneti]
20. bill	/bɪl/	ebiri	[eβiri]
21. bolt	/ˈbəʊlt/	eboriti	[eβoriti]

22. bathroom	/ˈbɑːθrʊm/	ebaturumu	[eβaturumu]
23. bag	/ˈbæg/	ebagi	[eβayi]
24. blanket	/ˈblæŋkɪt/	oborangeti	[oβora ^ŋ geti]
25. balcony	/ˈbælkəni/	ebarikoni	[eβarikoni]
26. basin	/ˈbeɪsn/	ebeseni	[eβeseni]
27. bomb	/bɒm/	ebomu	[eβomu]
28. brush	/brʌʃ/	eburasi	[eβurasi]
29. biscuit	/ˈbɪskɪt/	egesuguti	[eγesuγuti]
30. acre	/ˈeɪkə/	eeka	[ε.ε.ka]
31. account	/əˈkaʊnt/	eakaonti	[eakaonti]
32. aerial	/ˈeəriəl/	eerio	[e.e.riɔ]
33. helicopter	/ˈhelɪkɒptə/	erikobita	[erikoβita]
34. headmaster	/ˈhedˈmɑːstə/	etumasita	[etumasita]
35. hotpot	/ˈhɒtpɒt/	eotiboti	[e.o.tiβoti]
36. chimney	/ˈtʃɪmni/	echimuni	[ecimuni]
37. car	/kɑː/	ekaa	[eka.a]
38. cabbage	/ˈkæbɪdʒ/	ekabichi	[ekaβici]
39. cupboard	/ˈkʌpəd/	ekabati	[ekaβati]
40. chief	/tʃiːf/	echibu	[eciβu]
41. cheque	/tʃek/	echeki	[eceki]
42. camisole	/ˈkæmɪsəʊl/	ekamisi	[ekamisi]
43. computer	/kəmˈpjʊːtə/	ekombiuta	[eko ^m bjuta]
44. company	/ˈkʌmpəni/	ekambani	[eka ^m bani]

45. captain	/'kæptɪn/	ekabuteni	[ekaβuteni]
46. camp	/kæmp/	ekambi	[eka ^m bi]
47. camera	/kæməɾə/	ekamera	[ekamera]
48. colour	/'kʌlə/	ekara	[ekara]
49. carrot	/'kærət/	ekarati	[ekarati]
50. calendar	/'kælɪndə/	ekarenda	[ekarenda]
51. carton	/'ka:tɪn/	ekatoni	[ekatoni]
52. carpet	/'ka:pɪt/	ekabeti	[ekaβeti]
53. curtain	/'kɜ:tɪn/	ekateni	[ekateni]
54. corridor	/'kɒrɪdɔ:/	ekorido	[ekorido]
55. county	/'kaʊntɪ/	ekaonti	[eka.o.nti]
56. conductor	/kən'dʌktə/	ekondagita	[ekondayita]
57. cushion	/'kʊʃən/	ekosoni	[ekosoni]
58. certificate	/sə'tɪfɪkət/	esatibigeti	[esatɪβiyeti]
59. container	/kən'teɪnə/	ekonteina	[ekonte.i.na]
60. cooker	/'kʊkə/	ekuka	[ekuka]
61. cake	/keɪk/	ekeki	[ekeki]
62. chairman	/'tʃeəmən/	echeamani	[echeamani]
63. cabinet	/'kæbɪnɪt/	ekabineti	[ekaβineti]
64. class	/kla:s/	ekerasi	[ekerasi]
65. clinic	/'klɪnɪk/	ekiriniki	[ekiriniki]
66. case	/keɪs/	ekesi	[ekesi]
67. cashier	/kæ'ʃɪə/	ekesia	[ekesia]

68. chart	/ʃɑ:t/	echati	[ecati]
69. duster	/'dʌstə/	etasita	[etasita]
70. desk	/desk/	etesiki	[etesiki]
71. charger	/'ʃɑ:ʒə/	echacha	[ecaca]
72. frame	/freɪm/	eburemu	[eβuremu]
73. fees	/fi:z/	ebisi	[eβisi]
74. fuse	/fju:z/	ebiusi	[eβiusi]
75. fifty	/'fɪftɪ/	bibiti	[βiβiβi]
76. gate	/geɪt/	egeita	[eγeita]
77. gown	/gaʊn/	egaoni	[eγaoni]
78. gas	/gæs/	egasi	[eγasi]
79. gear	/gɪə/	egia	[eγi.a]
80. glass	/glɑ:s/	ekerasi	[ekerasi]
81. gazette	/gə'zet/	engaseti	[e ⁿ gaseti]
82. guitar	/gɪtɑ:/	egita	[eγita]
83. gallon	/gælən/	egaroni	[eγaroni]
84. governor	/'gʌvənə/	egabana	[eγaβana]
85. jumper	/'dʒʌmpə/	echamba	[eca ^m ba]
86. juice	/dʒu:s/	echuisi	[ecuisi]
87. matatu	/mæ'tætu/	ematatu	[ematatu]
88. million	/'mɪljən/	emirioni	[emirioni]
89. machine	/mə'ʃi:n/	amasini	[amasini]
90. net	/net/	eneti	[eneti]

91.	roller	/ˈrɒlɚ/	erore	[ɛrɔrɛ]
92.	ruler	/ˈru:lə/	erura	[erura]
93.	radio	/ˈreɪdɪəʊ/	eredio	[eredio]
94.	remote	/rɪˈməʊt/	erimoti	[erimoti]
95.	referendum	/refəˈrendəm/	eriberandamu	[erɪβerɑːndɑːmu]
96.	receipt	/rɪˈsi:t/	risiti	[risiti]
97.	railway	/ˈreɪlweɪ/	ereri	[ereri]
98.	register	/ˈredʒɪstə/	erechesita	[erecesita]
99.	jacket	/ˈdʒækɪt/	echaketi	[ecaketi]
100.	jug	/dʒʌg/	echagi	[ecayɪ]
101.	loan	/ləʊn/	eroni	[eroni]
102.	lock	/lɒk/	eroki	[eroki]
103.	lawyer	/ˈlɔːjə/	eroya	[eroja]
104.	lorry	/ˈlɔːrɪ/	erori	[erori]
105.	lesson	/ˈlesn/	ereseni	[ereseni]
106.	license	/ˈlaɪsəns/	eresesi	[eresesi]
107.	style	/stɑɪl/	esitaeri	[esita.e.ri]
108.	stamp	/stæmp/	esitambu	[esitaːmbu]
109.	stake	/steɪk/	esiteki	[esiteki]
110.	stage	/steɪdʒ/	esitechi	[esiteci]
111.	station	/steɪʃn/	esiteseni	[esiteseni]
112.	store	/stɔː/	esito	[esito]
113.	stock	/stɒk/	esitoki	[esitoki]
114.	stool	/stu:l/	esuturu	[esuturu]

115.	sofa	/'səʊfə/	esoba	[esoβa]
116.	syrup	/'sɪrəp/	esirabu	[esiraβu]
117.	syringe	/'sɪrɪndʒ/	esirenchi	[esirenci]
118.	senator	/'senətə/	eseneta	[eseneta]
119.	shilling	/'ʃɪlɪŋ/	esiringi	[esiri ^ɪ gi]
120.	sufuria	/sufuria/	esuguri	[esuyuri]
121.	shirt	/ʃɜ:t/	esati	[esati]
122.	skirt	/skɜ:t/	esigati	[esiyati]
123.	slip	/slɪp/	esiribu	[esiriβu]
124.	switch	/swɪtʃ/	eswichi	[eswici]
125.	suit	/sju:t/	esuti	[esuti]
126.	socket	/'sɒkɪt/	esogeti	[esoɣeti]
127.	school	/sku:l/	esukuru	[esukuru]
128.	stove	/stəʊv/	esitobu	[esitoβu]
129.	stair	/steə/	esitea	[esite.a]
130.	sweater	/'swetə/	eswenta	[eswenta]
131.	secretary	/'sekrətəri/	esekeretari	[esekeretari]
132.	district	/'dɪstrɪkt/	etisirigiti	[etisiriyiti]
133.	tractor	/'træktə/	ekeragita	[ekerayita]
134.	T.V	/ti:'vi:/	etibi	[etiβi]
135.	tissue	/'tɪʃu:/	etisiu	[etisiu]
136.	toy	/tɔɪ/	etoi	[etoi]
137.	trough	/trʌʃ/	eturabu	[eturaβu]

138.	t-shirt	/ˈtiːʃɜːt/	etisati	[etisati]
139.	trolley	/ˈtrɒli/	eturori	[eturori]
140.	tray	/treɪ/	eturei	[eturei]
141.	treasurer	/ˈtreʒərə/	eturesara	[eturesara]
142.	tyre	/ˈtəɪə/	etaeri	[etaeri]
143.	trumpet	/ˈtrʌmpɪt/	etarumbeta	[etaru ^m beta]
144.	towel	/ˈtaʊəl/	etauro	[etauro]
145.	town	/taʊn/	etaoni	[etaoni]
146.	ticket	/ˈtɪkɪt/	etigiti	[etiɣiti]
147.	team	/ti:m/	etimu	[etimu]
148.	transfer	/ˈtrænsfɜː/	eturansiba	[eturansiβa]
149.	trailer	/ˈtreɪlə/	eturera	[eturera]
150.	thermos	/ˈθɜːməs/	etamosi	[etamosi]
151.	tank	/tæŋk/	etangi	[eta ^ŋ gi]
152.	trophy	/ˈtrɒfi/	eturobi	[eturoβi]
153.	taxi	/ˈtæksɪ/	etagisi	[etayisi]
154.	office	/ˈɒfis/	obisi	[oβisi]
155.	pigmy	/ˈpɪgmɪ/	ebigimi	[eβiɣimi]
156.	pistol	/ˈpɪstɒl/	ebisito	[eβisito]
157.	plastic	/ˈplæstɪk/	eburasitiki	[eβurasitiki]
158.	pail	/peɪl/	ebeiri	[eβeiri]
159.	principal	/ˈprɪnsəpəl/	eburinsibo	[eβurinsiβo]
160.	pillow	/ˈpɪləʊ/	ebiro	[eβiro]

161.	university	/ju:nɪ'vɜ:sɪtɪ/	eyunibasiti	[ejuniβasiti]
162.	vest	/vest/	ebesiti	[eβesiti]
163.	wire	/'waɪə/	ewaya	[ewaja]
164.	wine	/waɪn/	ewaini	[ewaini]

APPENDIX IV: BUDGET

Activity	Quantity	Unit Cost	Total Kshs
Proposal Preparation Stationery			6,000.00
Internet	100 GB	@ 100	10,000.00
Printing/ Binding for Departmental Defense	40 pages	Kshs. 3 per page for 20 copies	2,400.00
Revisions	4 copies	Kshs @ 120	480.00
SUB TOTAL			18,840.00
NACOSTI and Cyber Charges			2,500.00
Data Collection Expenses			10,000.00
SUB TOTAL			12,500.00
Thesis Printing for School Defense	250 pages	Kshs. 750 for 4 copies	3,000.00
Thesis final copies printing	250 pages	Kshs. 750 per 6 copies	4,500.00
Hard Cover Binding	6	@500	3,000.00
SUB TOTAL			10,500.00
PhD Fees	6 semesters	Kshs. 125,000 per semester	750,000.00
SUB TOTAL			752, 000.00
GRAND TOTAL			791,840.00

APPENDIX V: APPROVAL OF RESEARCH THESIS FROM KENYATTA UNIVERSITY



KENYATTA UNIVERSITY
GRADUATE SCHOOL

E-mail: dean-graduate@ku.ac.ke

Website: www.ku.ac.ke

P.O. Box 43844, 00100
NAIROBI, KENYA
Tel. 810901 Ext. 4150

Internal Memo

FROM: Dean, Graduate School

DATE: 2nd November, 2016

TO: Mose Gesare Edinah
C/o English & Linguistics Dept.

REF: C82/28600/2014

SUBJECT: APPROVAL OF RESEARCH PROJECT PROPOSAL

We acknowledge receipt of your revised Research Proposal as per our recommendations raised by the Graduate School Board of 31st August, 2016 entitled "A Morphophonological Analysis of Borrowed Segments in Ekegusii, Kenya: An Optimality Perspective".

You may now proceed with your Data Collection, Subject to Clearance with Director General, National Commission for Science, Technology and Innovation.

As you embark on your data collection, please note that you will be required to submit to Graduate School completed Supervision Tracking Forms per semester. The form has been developed to replace the Progress Report Forms. The Supervision Tracking Forms are available at the University's Website under Graduate School webpage downloads.

Thank you

REUBEN MURIUKI
FOR: DEAN, GRADUATE SCHOOL

c.c. Chairman, Department of English & Linguistics

Supervisors:

1. Dr. Henry Simiyu Nandelenga
C/o Department of English & Linguistics
Kenyatta University
2. Dr. Gerry Ayieko
Department of English & Linguistics
Kenyatta University

RM/awn

APPENDIX VI: RESEARCH AUTHORISATION FROM NACOSTI



NATIONAL COMMISSION FOR SCIENCE, TECHNOLOGY AND INNOVATION

Telephone: 020 400 7000,
0713 788787,0735404245
Fax: +254-20-318245,318249
Email: dg@nacosti.go.ke
Website: www.nacosti.go.ke
When replying please quote

NACOSTI, Upper Kabete
Off Waiyaki Way
P.O. Box 30623-00100
NAIROBI-KENYA

Ref No. **NACOSTI/P/18/27545/20759**

Date: **16th January, 2017**

Mose Gesare
Kenyatta University
P.O Box 43844-00100
NAIROBI.

RE: RESEARCH AUTHORIZATION

Following your application for authority to carry out research on "*A morphophonological analysis of borrowed segments in Ekegusii: An optimality perspective*" I am pleased to inform you that you have been authorized to undertake research in **Kisii County** for the period ending **16th January, 2018**.

You are advised to report to **the County Commissioner and the County Director of Education, Kisii County** before embarking on the research project.

Kindly note that, as an applicant who has been licensed under the Science, Technology and Innovation Act, 2013 to conduct research in Kenya, you shall deposit a **copy** of the final research report to the Commission within **one year** of completion. The soft copy of the same should be submitted through the Online Research Information System.

BONIFACE WANYAMA.
FOR: DIRECTOR-GENERAL/CEO

Copy to:

The County Commissioner
Kisii County.

The County Director of Education
Kisii County.

APPENDIX VII: RESEARCH PERMIT FROM NACOSTI

**THIS IS TO CERTIFY THAT:
MS. MOSE GESARE
of KENYATTA UNIVERSITY, 515-900
Kiambu, has been permitted to conduct
research in Kisii County**

**Permit No : NACOSTI/P/18/27545/20759
Date Of Issue : 16th January,2018
Fee Recieved :Ksh 2000**

**on the topic: A MORPHOPHONOLOGICAL
ANALYSIS OF BORROWED SEGMENTS IN
EKEGUSII: AN OPTIMALITY PERSPECTIVE**

**for the period ending:
16th January,2019**

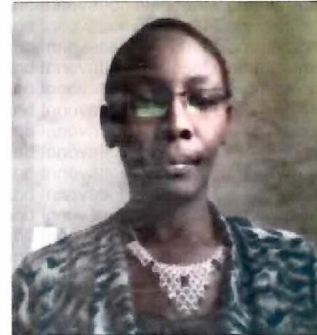

.....
**Applicant's
Signature**

.....
**Director General
National Commission for Science,
Technology & Innovation**

CONDITIONS

1. The License is valid for the proposed research, research site specified period.
2. Both the Licence and any rights thereunder are non-transferable.
3. Upon request of the Commission, the Licensee shall submit a progress report.
4. The Licensee shall report to the County Director of Education and County Governor in the area of research before commencement of the research.
5. Excavation, filming and collection of specimens are subject to further permissions from relevant Government agencies.
6. This Licence does not give authority to transfer research materials.
7. The Licensee shall submit two (2) hard copies and upload a soft copy of their final report.
8. The Commission reserves the right to modify the conditions of this Licence including its cancellation without prior notice.



REPUBLIC OF KENYA



**National Commission for Science,
Technology and Innovation**

**RESEARCH CLEARANCE
PERMIT**

Serial No.A 17092

CONDITIONS: see back page